

## Standard Development Timeline

---

*This section is maintained by the drafting team during the development of the standard and will be removed when the standard becomes effective.*

### Development Steps Completed

1. SAR posted for comment on January 15, 2014
2. Standard Drafting Team appointed on January 29, 2014
3. First 45-Day Comment and Ballot Period concluded on July 16, 2014
4. Additional 45-Day Comment Period and Ballot concluded on October 17, 2014

### Description of Current Draft

This draft standard is being posted for an additional comment period and ballot. The draft includes modifications to meet the directives of FERC Order No. 791.

Anticipated Actions	Anticipated Date
Additional 45-Day Comment Period and Ballot	November 2014
Final Ballot is Conducted	January 2015
Board of Trustees (Board) Adoption	February 2015
Filing to Applicable Regulatory Authorities	February 2015

## Version History

Version	Date	Action	Change Tracking
1	1/16/06	R3.2 — Change “Control Center” to “control center.”	3/24/06
2	9/30/09	<p>Modifications to clarify the requirements and to bring the compliance elements into conformance with the latest guidelines for developing compliance elements of standards.</p> <p>Removal of reasonable business judgment.</p> <p>Replaced the RRO with the RE as a responsible entity.</p> <p>Rewording of Effective Date.</p> <p>Changed compliance monitor to Compliance Enforcement Authority.</p>	
3	12/16/09	<p>Updated Version Number from -2 to -3</p> <p>In Requirement 1.6, deleted the sentence pertaining to removing component or system from service in order to perform testing, in response to FERC order issued September 30, 2009.</p>	
3	12/16/09	Approved by the NERC Board of Trustees.	
3	3/31/10	Approved by FERC.	
4	1/24/11	Approved by the NERC Board of Trustees.	
5	11/26/12	Adopted by the NERC Board of Trustees.	Modified to coordinate with other CIP standards and to revise format to use RBS Template.
5	11/22/13	FERC Order issued approving CIP-003-5.	
6	11/13/14	Adopted by the NERC Board of Trustees.	

*When this standard has received ballot approval, the text boxes will be moved to the Application Guidelines Section of the Standard.*

## **A. Introduction**

- 1. Title:** Cyber Security — Security Management Controls
- 2. Number:** CIP-003-7
- 3. Purpose:** To specify consistent and sustainable security management controls that establish responsibility and accountability to protect BES Cyber Systems against compromise that could lead to misoperation or instability in the Bulk Electric System (BES).
- 4. Applicability:**
  - 4.1. Functional Entities:** For the purpose of the requirements contained herein, the following list of functional entities will be collectively referred to as “Responsible Entities.” For requirements in this standard where a specific functional entity or subset of functional entities are the applicable entity or entities, the functional entity or entities are specified explicitly.
    - 4.1.1 Balancing Authority**
    - 4.1.2 Distribution Provider** that owns one or more of the following Facilities, systems, and equipment for the protection or restoration of the BES:
      - 4.1.2.1** Each underfrequency Load shedding (UFLS) or undervoltage Load shedding (UVLS) system that:
        - 4.1.2.1.1** is part of a Load shedding program that is subject to one or more requirements in a NERC or Regional Reliability Standard; and
        - 4.1.2.1.2** performs automatic Load shedding under a common control system owned by the Responsible Entity, without human operator initiation, of 300 MW or more.
      - 4.1.2.2** Each Special Protection System (SPS) or Remedial Action Scheme (RAS) where the SPS or RAS is subject to one or more requirements in a NERC or Regional Reliability Standard.
      - 4.1.2.3** Each Protection System (excluding UFLS and UVLS) that applies to Transmission where the Protection System is subject to one or more requirements in a NERC or Regional Reliability Standard.
      - 4.1.2.4** Each Cranking Path and group of Elements meeting the initial switching requirements from a Blackstart Resource up to and including the first interconnection point of the starting station service of the next generation unit(s) to be started.
    - 4.1.3 Generator Operator**

**4.1.4 Generator Owner**

**4.1.5 Interchange Coordinator or Interchange Authority**

**4.1.6 Reliability Coordinator**

**4.1.7 Transmission Operator**

**4.1.8 Transmission Owner**

**4.2. Facilities:** For the purpose of the requirements contained herein, the following Facilities, systems, and equipment owned by each Responsible Entity in 4.1 above are those to which these requirements are applicable. For requirements in this standard where a specific type of Facilities, system, or equipment or subset of Facilities, systems, and equipment are applicable, these are specified explicitly.

**4.2.1 Distribution Provider:** One or more of the following Facilities, systems and equipment owned by the Distribution Provider for the protection or restoration of the BES:

**4.2.1.1** Each UFLS or UVLS System that:

**4.2.1.1.1** is part of a Load shedding program that is subject to one or more requirements in a NERC or Regional Reliability Standard; and

**4.2.1.1.2** performs automatic Load shedding under a common control system owned by the Responsible Entity, without human operator initiation, of 300 MW or more.

**4.2.1.2** Each SPS or RAS where the SPS or RAS is subject to one or more requirements in a NERC or Regional Reliability Standard.

**4.2.1.3** Each Protection System (excluding UFLS and UVLS) that applies to Transmission where the Protection System is subject to one or more requirements in a NERC or Regional Reliability Standard.

**4.2.1.4** Each Cranking Path and group of Elements meeting the initial switching requirements from a Blackstart Resource up to and including the first interconnection point of the starting station service of the next generation unit(s) to be started.

**4.2.2 Responsible Entities listed in 4.1 other than Distribution Providers:**

All BES Facilities.

**4.2.3 Exemptions:** The following are exempt from Standard CIP-003-7:

**4.2.3.1** Cyber Assets at Facilities regulated by the Canadian Nuclear Safety Commission.

**4.2.3.2** Cyber Assets associated with communication networks and data communication links between discrete Electronic Security Perimeters (ESPs).

**4.2.3.3** The systems, structures, and components that are regulated by the Nuclear Regulatory Commission under a cyber security plan pursuant to 10 C.F.R. Section 73.54.

**4.2.3.4** For Distribution Providers, the systems and equipment that are not included in section 4.2.1 above.

**5. Effective Dates:**

See Implementation Plan for CIP-003-7.

**6. Background:**

Standard CIP-003 exists as part of a suite of CIP Standards related to cyber security, which require the initial identification and categorization of BES Cyber Systems and require organizational, operational, and procedural controls to mitigate risk to BES Cyber Systems.

The term *policy* refers to one or a collection of written documents that are used to communicate the Responsible Entities' management goals, objectives and expectations for how the Responsible Entity will protect its BES Cyber Systems. The use of *policies* also establishes an overall governance foundation for creating a culture of security and compliance with laws, regulations, and standards.

The term *documented processes* refers to a set of required instructions specific to the Responsible Entity and to achieve a specific outcome. This term does not imply any naming or approval structure beyond what is stated in the requirements. An entity should include as much as it believes necessary in its documented processes, but it must address the applicable requirements.

The terms *program* and *plan* are sometimes used in place of *documented processes* where it makes sense and is commonly understood. For example, documented processes describing a response are typically referred to as *plans* (i.e., incident response plans and recovery plans). Likewise, a security plan can describe an approach involving multiple procedures to address a broad subject matter.

Similarly, the term *program* may refer to the organization's overall implementation of its policies, plans, and procedures involving a subject matter. Examples in the standards include the personnel risk assessment program and the personnel training program. The full implementation of the CIP Cyber Security Reliability Standards could also be referred to as a program. However, the terms *program* and *plan* do not imply any additional requirements beyond what is stated in the standards.

Responsible Entities can implement common controls that meet requirements for multiple high, medium, and low impact BES Cyber Systems. For example, a single cyber security awareness program could meet the requirements for training personnel across multiple BES Cyber Systems.

Measures provide examples of evidence to show documentation and implementation of the requirement. These measures serve to provide guidance to entities in acceptable records of compliance and should not be viewed as an all-inclusive list.

Throughout the standards, unless otherwise stated, bulleted items in the requirements and measures are items that are linked with an “or,” and numbered items are items that are linked with an “and.”

Many references in the Applicability section use a threshold of 300 MW for UFLS and UVLS. This particular threshold of 300 MW for UVLS and UFLS was provided in Version 1 of the CIP Cyber Security Standards. The threshold remains at 300 MW since it is specifically addressing UVLS and UFLS, which are last ditch efforts to save the BES. A review of UFLS tolerances defined within Regional Reliability Standards for UFLS program requirements to date indicates that the historical value of 300 MW represents an adequate and reasonable threshold value for allowable UFLS operational tolerances.

## B. Requirements and Measures

### **Rationale for Requirement R1:**

One or more security policies enable effective implementation of the requirements of the cyber security Reliability Standards. The purpose of policies is to provide a management and governance foundation for all requirements that apply to a Responsible Entity's BES Cyber Systems. The Responsible Entity can demonstrate through its policies that its management supports the accountability and responsibility necessary for effective implementation of the requirements.

Annual review and approval of the cyber security policies ensures that the policies are kept-up-to-date and periodically reaffirms management's commitment to the protection of its BES Cyber Systems.

- R1.** Each Responsible Entity shall review and obtain CIP Senior Manager approval at least once every 15 calendar months for one or more documented cyber security policies that collectively address the following topics: [*Violation Risk Factor: Medium*] [*Time Horizon: Operations Planning*]
  - 1.1** For its high impact and medium impact BES Cyber Systems, if any:
    - 1.1.1.** Personnel and training (CIP-004);
    - 1.1.2.** Electronic Security Perimeters (CIP-005) including Interactive Remote Access;
    - 1.1.3.** Physical security of BES Cyber Systems (CIP-006);
    - 1.1.4.** System security management (CIP-007);
    - 1.1.5.** Incident reporting and response planning (CIP-008);
    - 1.1.6.** Recovery plans for BES Cyber Systems (CIP-009);
    - 1.1.7.** Configuration change management and vulnerability assessments (CIP-010);
    - 1.1.8.** Information protection (CIP-011); and
    - 1.1.9.** Declaring and responding to CIP Exceptional Circumstances.
  - 1.2** For its assets identified in CIP-002 containing low impact BES Cyber Systems, if any:
    - 1.2.1.** Cyber security awareness;
    - 1.2.2.** Physical security controls;
    - 1.2.3.** Electronic access controls for Low Impact External Routable Connectivity (LERC) and Dial-up Connectivity; and
    - 1.2.4.** Cyber Security Incident response

- M1.** Examples of evidence may include, but are not limited to, policy documents; revision history, records of review, or workflow evidence from a document management system that indicate review of each cyber security policy at least once every 15 calendar months; and documented approval by the CIP Senior Manager for each cyber security policy.

**Rationale for Requirement R2:**

In response to FERC Order No. 791, Requirement R2 requires entities to develop and implement cyber security plans to meet specific security control objectives for assets containing low impact BES Cyber Systems. The cyber security plan(s) covers four subject matter areas: (1) cyber security awareness; (2) physical security controls; (3) electronic access controls; and (4) Cyber Security Incident response. This plan(s), along with the cyber security policies required under Requirement R1, Part 1.2, provides a framework for operational, procedural, and technical safeguards for low impact BES Cyber Systems.

Considering the varied types of low impact BES Cyber Systems across the BES, Attachment 1 provides Responsible Entities flexibility on how to apply the security controls to meet the security objectives. Additionally, because many Responsible Entities have multiple-impact rated BES Cyber Systems, nothing in the requirement prohibits entities from using their high and medium impact BES Cyber System policies, procedures, and processes to implement security controls required for low impact BES Cyber Systems, as detailed in Requirement R2, Attachment 1.

Responsible Entities will use their list of assets containing low impact BES Cyber System(s) (developed pursuant to CIP-002) to substantiate the sites or locations associated with low impact BES Cyber Systems. However, there is no requirement or compliance expectation for Responsible Entities to maintain a list(s) of individual low impact BES Cyber Systems and their associated cyber assets or to maintain a list of authorized users.

- R2.** Each Responsible Entity with at least one asset identified in CIP-002 containing low impact BES Cyber Systems shall implement one or more documented cyber security plan(s) for its low impact BES Cyber Systems that include the sections in Attachment 1. *[Violation Risk Factor: Lower] [Time Horizon: Operations Planning]*

Note: An inventory, list, or discrete identification of low impact BES Cyber Systems or their BES Cyber Assets is not required. Lists of authorized users are not required.

- M2.** Evidence shall include each of the documented cyber security plan(s) that collectively include each of the sections in Attachment 1 and additional evidence to demonstrate implementation of the cyber security plan(s). Additional examples of evidence per section are located in Attachment 2.



**Rationale for Requirement R3:**

The identification and documentation of the single CIP Senior Manager ensures that there is clear authority and ownership for the CIP program within an organization, as called for in Blackout Report Recommendation 43. The language that identifies CIP Senior Manager responsibilities is included in the *Glossary of Terms used in NERC Reliability Standards* so that it may be used across the body of CIP standards without an explicit cross-reference.

FERC Order No. 706, Paragraph 296, requests consideration of whether the single senior manager should be a corporate officer or equivalent. As implicated through the defined term, the senior manager has “the overall authority and responsibility for leading and managing implementation of the requirements within this set of standards” which ensures that the senior manager is of sufficient position in the Responsible Entity to ensure that cyber security receives the prominence that is necessary. In addition, given the range of business models for responsible entities, from municipal, cooperative, federal agencies, investor owned utilities, privately owned utilities, and everything in between, the SDT believes that requiring the CIP Senior Manager to be a “corporate officer or equivalent” would be extremely difficult to interpret and enforce on a consistent basis.

- R3.** Each Responsible Entity shall identify a CIP Senior Manager by name and document any change within 30 calendar days of the change. [*Violation Risk Factor: Medium*]  
[*Time Horizon: Operations Planning*]
- M3.** An example of evidence may include, but is not limited to, a dated and approved document from a high level official designating the name of the individual identified as the CIP Senior Manager.

**Rationale for Requirement R4:**

The intent of the requirement is to ensure clear accountability within an organization for certain security matters. It also ensures that delegations are kept up-to-date and that individuals do not assume undocumented authority.

In FERC Order No. 706, Paragraphs 379 and 381, the Commission notes that Recommendation 43 of the 2003 Blackout Report calls for “clear lines of authority and ownership for security matters.” With this in mind, the Standard Drafting Team has sought to provide clarity in the requirement for delegations so that this line of authority is clear and apparent from the documented delegations.

- R4.** The Responsible Entity shall implement a documented process to delegate authority, unless no delegations are used. Where allowed by the CIP Standards, the CIP Senior

Manager may delegate authority for specific actions to a delegate or delegates. These delegations shall be documented, including the name or title of the delegate, the specific actions delegated, and the date of the delegation; approved by the CIP Senior Manager; and updated within 30 days of any change to the delegation. Delegation changes do not need to be reinstated with a change to the delegator. *[Violation Risk Factor: Lower] [Time Horizon: Operations Planning]*

- M4.** An example of evidence may include, but is not limited to, a dated document, approved by the CIP Senior Manager, listing individuals (by name or title) who are delegated the authority to approve or authorize specifically identified items.

## C. Compliance

### 1. Compliance Monitoring Process

#### 1.1. Compliance Enforcement Authority:

As defined in the NERC Rules of Procedure, “Compliance Enforcement Authority” (CEA) means NERC or the Regional Entity in their respective roles of monitoring and enforcing compliance with the NERC Reliability Standards.

#### 1.2. Evidence Retention:

The following evidence retention periods identify the period of time an entity is required to retain specific evidence to demonstrate compliance. For instances where the evidence retention period specified below is shorter than the time since the last audit, the CEA may ask an entity to provide other evidence to show that it was compliant for the full time period since the last audit.

The Responsible Entity shall keep data or evidence to show compliance as identified below unless directed by its CEA to retain specific evidence for a longer period of time as part of an investigation:

- Each Responsible Entity shall retain evidence of each requirement in this standard for three calendar years.
- If a Responsible Entity is found non-compliant, it shall keep information related to the non-compliance until mitigation is complete and approved or for the time specified above, whichever is longer.
- The CEA shall keep the last audit records and all requested and submitted subsequent audit records.

#### 1.3. Compliance Monitoring and Assessment Processes:

Compliance Audits

Self-Certifications

Spot Checking

Compliance Investigations

Self-Reporting

Complaints

#### 1.4. Additional Compliance Information:

None

2. Table of Compliance Elements

R #	Time Horizon	VRF	Violation Severity Levels (CIP-003-7)			
			Lower VSL	Moderate VSL	High VSL	Severe VSL
R1	Operations Planning	Medium	<p>The Responsible Entity documented and implemented one or more cyber security policies for its high impact and medium impact BES Cyber Systems, but did not address one of the nine topics required by R1. (R1.1)</p> <p>OR</p> <p>The Responsible Entity did not complete its review of the one or more documented cyber security policies for its high impact and medium impact BES Cyber Systems as required by R1 within 15 calendar months but did</p>	<p>The Responsible Entity documented and implemented one or more cyber security policies for its high impact and medium impact BES Cyber Systems, but did not address two of the nine topics required by R1. (R1.1)</p> <p>OR</p> <p>The Responsible Entity did not complete its review of the one or more documented cyber security policies for its high impact and medium impact BES Cyber Systems as required by R1 within 16 calendar months but did</p>	<p>The Responsible Entity documented and implemented one or more cyber security policies for its high impact and medium impact BES Cyber Systems, but did not address three of the nine topics required by R1. (R1.1)</p> <p>OR</p> <p>The Responsible Entity did not complete its review of the one or more documented cyber security policies for its high impact and medium impact BES Cyber Systems as required by R1 within 17 calendar months but did complete this review in less than or equal to 18</p>	<p>The Responsible Entity documented and implemented one or more cyber security policies for its high impact and medium impact BES Cyber Systems, but did not address four or more of the nine topics required by R1. (R1.1)</p> <p>OR</p> <p>The Responsible Entity did not have any documented cyber security policies for its high impact and medium impact BES Cyber Systems as required by R1. (R1.1)</p> <p>OR</p>

R #	Time Horizon	VRF	Violation Severity Levels (CIP-003-7)			
			Lower VSL	Moderate VSL	High VSL	Severe VSL
			complete this review in less than or equal to 16 calendar months of the previous review. (R1.1) OR The Responsible Entity did not complete its approval of the one or more documented cyber security policies for its high impact and medium impact BES Cyber Systems as required by R1 by the CIP Senior Manager within 15 calendar months but did complete this approval in less than or equal to 16 calendar months of	complete this review in less than or equal to 17 calendar months of the previous review. (R1.1) OR The Responsible Entity did not complete its approval of the one or more documented cyber security policies for its high impact and medium impact BES Cyber Systems as required by R1 by the CIP Senior Manager within 16 calendar months but did complete this approval in less than or equal to 17 calendar months of	calendar months of the previous review. (R1.1) OR The Responsible Entity did not complete its approval of the one or more documented cyber security policies for its high impact and medium impact BES Cyber Systems as required by R1 by the CIP Senior Manager within 17 calendar months but did complete this approval in less than or equal to 18 calendar months of the previous approval. (R1) OR The Responsible Entity documented one or more cyber security policies for its assets identified in CIP-002 containing low impact	The Responsible Entity did not complete its review of the one or more documented cyber security policies as required by R1 within 18 calendar months of the previous review. (R1) OR The Responsible Entity did not complete its approval of the one or more documented cyber security policies for its high impact and medium impact BES Cyber Systems as required by R1 by the CIP Senior Manager within 18 calendar months of

R #	Time Horizon	VRF	Violation Severity Levels (CIP-003-7)			
			Lower VSL	Moderate VSL	High VSL	Severe VSL
			the previous approval. (R1.1) OR The Responsible Entity documented one or more cyber security policies for its assets identified in CIP-002 containing low impact BES Cyber Systems, but did not address one of the four topics required by R1. (R1.2) OR The Responsible Entity did not complete its review of the one or more documented cyber security policies for its assets identified in CIP-002 containing low impact BES Cyber Systems as	the previous approval. (R1.1) OR The Responsible Entity documented one or more cyber security policies for its assets identified in CIP-002 containing low impact BES Cyber Systems, but did not address two of the four topics required by R1. (R1.2) OR The Responsible Entity did not complete its review of the one or more documented cyber security policies for its assets identified in CIP-002 containing low impact BES Cyber Systems as	BES Cyber Systems, but did not address three of the four topics required by R1. (R1.2) OR The Responsible Entity did not complete its review of the one or more documented cyber security policies for its assets identified in CIP-002 containing low impact BES Cyber Systems as required by R1 within 17 calendar months but did not complete this review in less than or equal to 18 calendar months of the previous review. (R1.2) OR The Responsible Entity did not complete its approval of the one or more documented cyber security policies for its	the previous approval. (R1.1) OR The Responsible Entity documented one or more cyber security policies for its assets identified in CIP-002 containing low impact BES Cyber Systems, but did not address any of the four topics required by R1. (R1.2) OR The Responsible Entity did not have any documented cyber security policies for its assets identified in CIP-002 containing low impact BES Cyber Systems as required by R1. (R1.2)

R #	Time Horizon	VRF	Violation Severity Levels (CIP-003-7)			
			Lower VSL	Moderate VSL	High VSL	Severe VSL
			<p>required by Requirement R1 within 15 calendar months but did not complete this review in less than or equal to 16 calendar months of the previous review. (R1.2)</p> <p>OR</p> <p>The Responsible Entity did not complete its approval of the one or more documented cyber security policies for its assets identified in CIP-002 containing low impact BES Cyber Systems as required by Requirement R1 by the CIP Senior Manager within 15 calendar months but did not complete this</p>	<p>required by Requirement R1 within 16 calendar months but did not complete this review in less than or equal to 17 calendar months of the previous review. (R1.2)</p> <p>OR</p> <p>The Responsible Entity did not complete its approval of the one or more documented cyber security policies for its assets identified in CIP-002 containing low impact BES Cyber Systems as required by Requirement R1 by the CIP Senior Manager within 16 calendar months but</p>	<p>assets identified in CIP-002 containing low impact BES Cyber Systems as required by Requirement R1 by the CIP Senior Manager within 17 calendar months but did not complete this approval in less than or equal to 18 calendar months of the previous approval. (R1.2)</p>	<p>OR</p> <p>The Responsible Entity did not complete its approval of the one or more documented cyber security policies for its assets identified in CIP-002 containing low impact BES Cyber Systems as required by Requirement R1 by the CIP Senior Manager within 18 calendar months of the previous approval. (R1.2)</p>

R #	Time Horizon	VRF	Violation Severity Levels (CIP-003-7)			
			Lower VSL	Moderate VSL	High VSL	Severe VSL
			approval in less than or equal to 16 calendar months of the previous approval. (R1.2)	did complete this approval in less than or equal to 17 calendar months of the previous approval. (R1.2)		
<b>R2</b>	<b>Operations Planning</b>	<b>Lower</b>	<p>The Responsible Entity documented its cyber security plan(s) for its assets containing low impact BES Cyber Systems, but failed to document cyber security awareness according to CIP-003-7, Requirement R2, Attachment 1, Section 1. (R2)</p> <p>OR</p> <p>The Responsible Entity documented its cyber security plan(s) for its assets containing low impact BES Cyber</p>	<p>The Responsible Entity documented its cyber security plan(s) for its assets containing low impact BES Cyber Systems, but failed to reinforce cyber security practices at least once every 15 calendar months according to CIP-003-7, Requirement R2, Attachment 1, Section 1. (R2)</p> <p>OR</p> <p>The Responsible Entity documented one or more incident response plans</p>	<p>The Responsible Entity documented one or more incident response plans within its cyber security plan(s) for its assets containing low impact BES Cyber Systems, but failed to test each Cyber Security Incident response plan(s) at least once every 36 calendar months according to CIP-003-7, Requirement R2, Attachment 1, Section 4. (R2)</p> <p>OR</p> <p>The Responsible Entity documented the determination of</p>	<p>The Responsible Entity failed to document or implement one or more cyber security plan(s) for its assets containing low impact BES Cyber Systems according to CIP-003-7, Requirement R2, Attachment 1. (R2)</p>



R #	Time Horizon	VRF	Violation Severity Levels (CIP-003-7)			
			Lower VSL	Moderate VSL	High VSL	Severe VSL
			<p>Systems, but failed to document one or more Cyber Security Incident response plans according to CIP-003-7, Requirement R2, Attachment 1, Section 4. (R2)</p> <p>OR</p> <p>The Responsible Entity documented one or more incident response plans within its cyber security plan(s) for its assets containing low impact BES Cyber Systems, but failed to update each Cyber Security Incident response plan(s) within 180 days according to CIP-003-7, Requirement R2,</p>	<p>within its cyber security plan(s) for its assets containing low impact BES Cyber Systems, but failed to include the process for identification, classification, and response to Cyber Security Incidents according to CIP-003-7, Requirement R2, Attachment 1, Section 4. (R2)</p> <p>OR</p> <p>The Responsible Entity documented its cyber security plan(s) for its assets containing low impact BES Cyber Systems, but failed to document the determination of</p>	<p>whether an identified Cyber Security Incident is a Reportable Cyber Security Incident, but failed to notify the Electricity Sector Information Sharing and Analysis Center (ES-ISAC) according to CIP-003-7, Requirement R2, Attachment 1, Section 4. (R2)</p> <p>OR</p> <p>The Responsible Entity documented and implemented electronic access controls for LERC, but failed to implement a LEAP or permit inbound and outbound access according to CIP-003-7, Requirement R2, Attachment 1, Section 3. (R2)</p> <p>OR</p>	

R #	Time Horizon	VRF	Violation Severity Levels (CIP-003-7)			
			Lower VSL	Moderate VSL	High VSL	Severe VSL
			Attachment 1, Section 4. (R2)	<p>whether an identified Cyber Security Incident is a Reportable Cyber Security Incident and subsequent notification to the Electricity Sector Information Sharing and Analysis Center (ES-ISAC) according to CIP-003-7, Requirement R2, Attachment 1, Section 4.</p> <p>OR</p> <p>The Responsible Entity documented its cyber security plan(s) for its assets containing low impact BES Cyber Systems, but failed to document physical security controls according to CIP-003-7,</p>	<p>The Responsible Entity documented and implemented electronic access controls for its assets containing low impact BES Cyber Systems, but failed to document and implement authentication of all Dial-up Connectivity, if any, that provides access to low impact BES Cyber Systems according to CIP-003-7, Requirement R2, Attachment 1, Section 3. (R2)</p> <p>OR</p> <p>The Responsible Entity documented the physical access controls for its assets containing low impact BES Cyber Systems, but failed to implement the physical security controls according to CIP-003-7,</p>	

R #	Time Horizon	VRF	Violation Severity Levels (CIP-003-7)			
			Lower VSL	Moderate VSL	High VSL	Severe VSL
				Requirement R2, Attachment 1, Section 2. (R2)  OR  The Responsible Entity documented its cyber security plan(s) for its assets containing low impact BES Cyber Systems, but failed to document electronic access controls according to CIP-003-7, Requirement R2, Attachment 1, Section 3. (R2)	Requirement R2, Attachment 1, Section 2. (R2)	
<b>R3</b>	<b>Operations Planning</b>	<b>Medium</b>	The Responsible Entity has identified by name a CIP Senior Manager, but did not document changes to the CIP Senior Manager within 30 calendar days but did	The Responsible Entity has identified by name a CIP Senior Manager, but did not document changes to the CIP Senior Manager within 40 calendar	The Responsible Entity has identified by name a CIP Senior Manager, but did not document changes to the CIP Senior Manager within 50 calendar days but did document this change in	The Responsible Entity has not identified, by name, a CIP Senior Manager.  OR

R #	Time Horizon	VRF	Violation Severity Levels (CIP-003-7)			
			Lower VSL	Moderate VSL	High VSL	Severe VSL
			document this change in less than 40 calendar days of the change. (R3)	days but did document this change in less than 50 calendar days of the change. (R3)	less than 60 calendar days of the change. (R3)	The Responsible Entity has identified by name a CIP Senior Manager, but did not document changes to the CIP Senior Manager within 60 calendar days of the change. (R3)
<b>R4</b>	<b>Operations Planning</b>	<b>Lower</b>	The Responsible Entity has identified a delegate by name, title, date of delegation, and specific actions delegated, but did not document changes to the delegate within 30 calendar days but did document this change in less than 40 calendar days of the change. (R4)	The Responsible Entity has identified a delegate by name, title, date of delegation, and specific actions delegated, but did not document changes to the delegate within 40 calendar days but did document this change in less than 50 calendar days of the change. (R4)	The Responsible Entity has identified a delegate by name, title, date of delegation, and specific actions delegated, but did not document changes to the delegate within 50 calendar days but did document this change in less than 60 calendar days of the change. (R4)	The Responsible Entity has used delegated authority for actions where allowed by the CIP Standards, but does not have a process to delegate actions from the CIP Senior Manager. (R4)  OR The Responsible Entity has identified a delegate by name, title, date of delegation, and

R #	Time Horizon	VRF	Violation Severity Levels (CIP-003-7)			
			Lower VSL	Moderate VSL	High VSL	Severe VSL
						specific actions delegated, but did not document changes to the delegate within 60 calendar days of the change. (R4)

**D. Regional Variances**

None.

**E. Interpretations**

None.

**F. Associated Documents**

None.

## CIP-003-7 - Attachment 1

### Required Sections for Cyber Security Plan(s) for Assets Containing Low Impact BES Cyber Systems

Responsible Entities shall include each of the sections provided below in the cyber security plan(s) required under Requirement R2.

Responsible Entities with multiple-impact BES Cyber Systems ratings can utilize policies, procedures, and processes for their high or medium impact BES Cyber Systems to fulfill the sections for the development of low impact cyber security plan(s). Each Responsible Entity can develop a cyber security plan(s) either by individual asset or groups of assets.

**Section 1. Cyber Security Awareness:** Each Responsible Entity shall reinforce, at least once every 15 calendar months, cyber security practices (which may include associated physical security practices).

**Section 2. Physical Security Controls:** Each Responsible Entity shall control physical access, based on need as determined by the Responsible Entity, to (1) the asset or the locations of the low impact BES Cyber Systems within the asset and (2) the Low Impact BES Cyber System Electronic Access Points (LEAPs), if any.

**Section 3. Electronic Access Controls:** Each Responsible Entity shall:

- 3.1** For LERC, if any, implement a LEAP to permit only necessary inbound and outbound bi-directional routable protocol access; and
- 3.2** Implement authentication for all Dial-up Connectivity, if any, that provides access to low impact BES Cyber Systems, per Cyber Asset capability.

**Section 4. Cyber Security Incident Response:** Each Responsible Entity shall have one or more Cyber Security Incident response plan(s), either by asset or group of assets, which shall include:

- 4.1** Identification, classification, and response to Cyber Security Incidents;
- 4.2** Determination of whether an identified Cyber Security Incident is a Reportable Cyber Security Incident and subsequent notification to the Electricity Sector Information Sharing and Analysis Center (ES-ISAC), unless prohibited by law;
- 4.3** Identification of the roles and responsibilities for Cyber Security Incident response by groups or individuals;
- 4.4** Incident handling for Cyber Security Incidents;
- 4.5** Testing the Cyber Security Incident response plan(s) at least once every 36 calendar months by: (1) responding to an actual Reportable Cyber Security Incident; (2) using a drill or tabletop exercise of a Reportable Cyber Security

Incident; or (3) using an operational exercise of a Reportable Cyber Security Incident; and

- 4.6** Updating the Cyber Security Incident response plan(s), if needed, within 180 calendar days after completion of a Cyber Security Incident response plan(s) test or actual Reportable Cyber Security Incident.

## CIP-003-7 - Attachment 2

### Examples of Evidence for Cyber Security Plan(s) for Assets Containing Low Impact BES Cyber Systems

Section 1 - Cyber Security Awareness: An example of evidence for Section 1 may include, but is not limited to, documentation that the reinforcement of cyber security practices occurred at least once every 15 calendar months. The evidence could be documentation through one or more of the following methods:

- Direct communications (for example, e-mails, memos, or computer-based training);
- Indirect communications (for example, posters, intranet, or brochures); or
- Management support and reinforcement (for example, presentations or meetings).

Section 2 - Physical Security Controls: Examples of evidence for Section 2 may include, but are not limited to:

- Documentation of the selected access control(s) (e.g., card key, locks, perimeter controls), monitoring controls (e.g., alarm systems, human observation), or other operational, procedural, or technical physical security controls that control physical access to both:
  - a. The asset, if any, or the locations of the low impact BES Cyber Systems within the asset; and
  - b. The Cyber Asset, if any, containing the LEAP.

Section 3 - Electronic Access Controls: Examples of evidence for Section 3 may include, but are not limited to:

- Documentation showing that inbound and outbound connections for any LEAP are confined to only those the Responsible Entity deems necessary (e.g., by restricting IP addresses, ports, or services); and documentation of authentication for Dial-up Connectivity (e.g., dial out only to a preprogrammed number to deliver data, dial-back modems, modems that must be remotely controlled by the control center or control room, or access control on the BES Cyber System).

Section 4 - Cyber Security Incident Response: An example of evidence for Section 4 may include, but is not limited to, dated documentation, such as policies, procedures, or process documents of one or more Cyber Security Incident response plan(s) developed either by asset or group of assets that include the following processes:

1. to identify, classify, and respond to Cyber Security Incidents; to determine whether an identified Cyber Security Incident is a Reportable Cyber Security Incident and for notifying the Electricity Sector Information Sharing and Analysis Center (ES-ISAC);



2. to identify and document the roles and responsibilities for Cyber Security Incident response by groups of individuals (e.g., initiating, documenting, monitoring, reporting, etc.);
3. for incident handling of a Cyber Security Incident (e.g., containment, eradication, or recovery/incident resolution);
4. for testing the plan(s) along with the dated documentation that a test has been completed at least once every 36 calendar months; and
5. to update, as needed, Cyber Security Incident response plan(s) within 180 calendar days after completion of a test or actual Reportable Cyber Security Incident.

## Guidelines and Technical Basis

### Section 4 – Scope of Applicability of the CIP Cyber Security Standards

Section “4. Applicability” of the standards provides important information for Responsible Entities to determine the scope of the applicability of the CIP Cyber Security Requirements.

Section “4.1. Functional Entities” is a list of NERC functional entities to which the standard applies. If the entity is registered as one or more of the functional entities listed in Section 4.1, then the NERC CIP Cyber Security Standards apply. Note that there is a qualification in Section 4.1 that restricts the applicability in the case of Distribution Providers to only those that own certain types of systems and equipment listed in 4.2.

Section “4.2. Facilities” defines the scope of the Facilities, systems, and equipment owned by the Responsible Entity, as qualified in Section 4.1, that is subject to the requirements of the standard. In addition to the set of BES Facilities, Control Centers, and other systems and equipment, the list includes the set of systems and equipment owned by Distribution Providers. While the NERC Glossary term “Facilities” already includes the BES characteristic, the additional use of the term BES here is meant to reinforce the scope of applicability of these Facilities where it is used, especially in this applicability scoping section. This in effect sets the scope of Facilities, systems, and equipment that is subject to the standards.

#### Requirement R1:

In developing policies in compliance with Requirement R1, the number of policies and their content should be guided by a Responsible Entity's management structure and operating conditions. Policies might be included as part of a general information security program for the entire organization, or as components of specific programs. The Responsible Entity has the flexibility to develop a single comprehensive cyber security policy covering the required topics, or it may choose to develop a single high-level umbrella policy and provide additional policy detail in lower level documents in its documentation hierarchy. In the case of a high-level umbrella policy, the Responsible Entity would be expected to provide the high-level policy as well as the additional documentation in order to demonstrate compliance with CIP-003-7, Requirement R1.

If a Responsible Entity has any high or medium impact BES Cyber Systems, the one or more cyber security policies must cover the nine subject matter areas required by CIP-003-7, Requirement R1, Part 1.1. If a Responsible Entity has identified from CIP-002 any assets containing low impact BES Cyber Systems, the one or more cyber security policies must cover the four subject matter areas required by Requirement R1, Part 1.2.

Responsible Entities that have multiple-impact rated BES Cyber Systems are not required to create separate cyber security policies for high, medium, or low impact BES Cyber Systems. The Responsible Entities have the flexibility to develop policies that cover all three impact ratings.

Implementation of the cyber security policy is not specifically included in CIP-003-7, Requirement R1 as it is envisioned that the implementation of this policy is evidenced through

successful implementation of CIP-003 through CIP-011. However, Responsible Entities are encouraged not to limit the scope of their cyber security policies to only those requirements in NERC cyber security Reliability Standards, but to develop a holistic cyber security policy appropriate for its organization. Elements of a policy that extend beyond the scope of NERC's cyber security Reliability Standards will not be considered candidates for potential violations although they will help demonstrate the organization's internal culture of compliance and posture towards cyber security.

For Part 1.1, the Responsible Entity should consider the following for each of the required topics in its one or more cyber security policies for medium and high impact BES Cyber Systems, if any:

### 1.1.1 Personnel and training (CIP-004)

- Organization position on acceptable background investigations
- Identification of possible disciplinary action for violating this policy
- Account management

### 1.1.2 Electronic Security Perimeters (CIP-005) including Interactive Remote Access

- Organization stance on use of wireless networks
- Identification of acceptable authentication methods
- Identification of trusted and untrusted resources
- Monitoring and logging of ingress and egress at Electronic Access Points
- Maintaining up-to-date anti-malware software before initiating Interactive Remote Access
- Maintaining up-to-date patch levels for operating systems and applications used to initiate Interactive Remote Access
- Disabling VPN "split-tunneling" or "dual-homed" workstations before initiating Interactive Remote Access
- For vendors, contractors, or consultants: include language in contracts that requires adherence to the Responsible Entity's Interactive Remote Access controls

### 1.1.3 Physical security of BES Cyber Systems (CIP-006)

- Strategy for protecting Cyber Assets from unauthorized physical access
- Acceptable physical access control methods
- Monitoring and logging of physical ingress

### 1.1.4 System security management (CIP-007)

- Strategies for system hardening
- Acceptable methods of authentication and access control

- Password policies including length, complexity, enforcement, prevention of brute force attempts
  - Monitoring and logging of BES Cyber Systems
- 1.1.5 Incident reporting and response planning (CIP-008)
- Recognition of Cyber Security Incidents
  - Appropriate notifications upon discovery of an incident
  - Obligations to report Cyber Security Incidents
- 1.1.6 Recovery plans for BES Cyber Systems (CIP-009)
- Availability of spare components
  - Availability of system backups
- 1.1.7 Configuration change management and vulnerability assessments (CIP-010)
- Initiation of change requests
  - Approval of changes
  - Break-fix processes
- 1.1.8 Information protection (CIP-011)
- Information access control methods
  - Notification of unauthorized information disclosure
  - Information access on a need-to-know basis
- 1.1.9 Declaring and responding to CIP Exceptional Circumstances
- Processes to invoke special procedures in the event of a CIP Exceptional Circumstance
  - Processes to allow for exceptions to policy that do not violate CIP requirements

Requirements relating to exceptions to a Responsible Entity's security policies were removed because it is a general management issue that is not within the scope of a reliability requirement. It is an internal policy requirement and not a reliability requirement. However, Responsible Entities are encouraged to continue this practice as a component of their cyber security policies.

In this and all subsequent required approvals in the NERC CIP Reliability Standards, the Responsible Entity may elect to use hardcopy or electronic approvals to the extent that there is sufficient evidence to ensure the authenticity of the approving party.

### **Requirement R2:**

Using the list of assets containing low impact BES Cyber Systems from CIP-002, the intent of the requirement is for each Responsible Entity to create, document, and implement one or more cyber security plan(s) that addresses objective criteria for the protection of low impact BES Cyber Systems. The protections required by Requirement R2 reflect the level of risk that misuse

or the unavailability of low impact BES Cyber Systems poses to the BES. The intent is that the required protections are part of a program that covers the low impact BES Cyber Systems collectively either at an asset or site level (assets containing low impact BES Cyber Systems), but not at an individual device or system level.

There are four subject matter areas, as identified in Attachment 1, that must be covered by the cyber security plan: (1) cyber security awareness, (2) physical security controls, (3) electronic access controls for LERC and Dial-up Connectivity, and (4) Cyber Security Incident response.

### **Requirement R2, Attachment 1**

As noted, Attachment 1 contains the sections that must be in the cyber security plan(s). The intent is to allow entities that have a combination of high, medium, and low impact BES Cyber Systems the flexibility to choose, if desired, to cover their low impact BES Cyber Systems (or any subset) under their programs used for the high or medium impact BES Cyber Systems rather than maintain two separate programs. Guidance for each of the four subject matter areas of Attachment 1 is provided below.

#### **Requirement R2, Attachment 1, Section 1 – Cyber Security Awareness**

The intent of the cyber security awareness program is for entities to reinforce good cyber security practices with their personnel at least once every 15 calendar months. The entity has the discretion to determine the topics to be addressed and the manner in which it will communicate these topics. As evidence of compliance, the Responsible Entity should be able to produce the awareness material that was delivered according to the delivery method(s) (e.g., posters, emails, or topics at staff meetings, etc.). The Responsible Entity is not required to maintain lists of recipients and track the reception of the awareness material by personnel.

Although the focus of the awareness is cyber security, it does not mean that only technology-related topics can be included in the program. Appropriate physical security topics (e.g., tailgating awareness and protection of badges for physical security, or “If you see something, say something” campaigns, etc.) are valid for cyber security awareness. The intent is to cover topics concerning any aspect of the protection of BES Cyber Systems.

#### **Requirement R2, Attachment 1, Section 2 – Physical Security Controls**

The Responsible Entity must document and implement methods to control physical access to (1) low impact BES Cyber Systems at assets containing low impact BES Cyber System(s) and (2) LEAPs, if any. If the LEAP is located within the BES asset and inherits the same controls outlined in Section 2, this can be noted by the Responsible Entity in either its policies or cyber security plan(s) to avoid duplicate documentation of the same controls.

The Responsible Entity has the flexibility in the selection of the methods used to meet the objective to control physical access to the asset(s) containing low impact BES Cyber Systems or the low impact BES Cyber System itself or LEAPs, if any. The Responsible Entity may use one or a combination of access controls, monitoring controls, or other operational, procedural, or technical physical security controls. Entities may use perimeter controls (e.g., fences with locked gates, guards, or site access policies, etc.) or more granular areas of physical access control in areas where low impact BES Cyber Systems are located, such as control rooms or

control houses. User authorization programs and lists of authorized users for physical access are not required although would help meet the security objective.

The objective is to control the physical access based on need as determined by the Responsible Entity. The need can be documented at the policy level for access to the site or systems. The requirement does not obligate an entity to specify a need for each access or authorization of a user for access.

Monitoring as a physical security control can be used as a complement or an alternative to access control. Examples of monitoring controls include, but are not limited to: (1) alarm systems to detect motion or entry into a controlled area, or (2) human observation of a controlled area. Monitoring does not necessarily require logging and maintaining logs but could include monitoring that physical access has occurred or been attempted (e.g., door alarm, or human observation, etc.). The monitoring does not need to be per low impact BES Cyber System but should be at the appropriate level to meet the security objective.

### **Requirement R2, Attachment 1, Section 3 – Electronic Access Controls**

Section 3 requires the establishment of boundary protections for low impact BES Cyber Systems when the low impact BES Cyber Systems have bi-directional routable protocol communication or Dial-up Connectivity to devices external to the asset containing the low impact BES Cyber Systems. The establishment of boundary protections is intended to control communication either into the asset containing low impact BES Cyber System(s) or to the low impact BES Cyber System itself to reduce the risks associated with uncontrolled communication using routable protocols or Dial-up Connectivity. The term “electronic access control” is used in the general sense, i.e., to control access, and not in the specific technical sense requiring authentication, authorization, and auditing. The Responsible Entity is not required to establish LERC communication or a LEAP if there is no bi-directional routable protocol communication or Dial-up Connectivity present. In the case where there is no external bi-directional routable protocol communication or Dial-up Connectivity, the Responsible Entity can document the absence of the communication within its low impact cyber security plan.

The defined terms LERC and LEAP are used to avoid confusion with the similar terms used for high and medium impact BES Cyber Systems (e.g., External Routable Connectivity (ERC) or Electronic Access Point (EAP)). To future-proof the standards, and in order to avoid future technology issues, the definitions specifically exclude “point-to-point communications between intelligent electronic devices that use routable communication protocols for time-sensitive protection or control functions between Transmission station or substation assets containing low impact BES Cyber Systems,” such as IEC 61850 messaging. This does not exclude Control Center communication but rather excludes the communication between the intelligent electronic devices themselves. A Responsible Entity using this technology is not expected to implement a LEAP even though there technically is LERC. This exception was included so as not to inhibit the functionality of the time-sensitive requirements related to this technology nor to preclude the use of such time-sensitive reliability enhancing functions if they use a routable protocol in the future.

When determining whether there is LERC to the low impact BES Cyber System, the definition uses the phrases “direct user-initiated interactive access or a direct device-to-device connection to a low impact BES Cyber System(s) from a Cyber Asset outside the asset containing those low impact BES Cyber System(s) via a bi-directional routable protocol connection.” The intent of “direct” in the definition is to indicate LERC exists if a person is sitting at another device outside of the asset containing the low impact BES Cyber System, and the person can connect to logon, configure, read, or interact, etc. with the low impact BES Cyber System using a bi-directional routable protocol within a single end-to-end protocol session. The reverse case would also be LERC, in which the individual sits at the low impact BES Cyber System and connects to a device outside the asset containing low impact BES Cyber Systems using a single end-to-end bi-directional routable protocol session. Additionally, for “device-to-device connection,” LERC exists if the Responsible Entity has devices outside of the asset containing the low impact BES Cyber System sending or receiving bi-directional routable communication from or to the low impact BES Cyber System.

When identifying a LEAP, Responsible Entities are provided flexibility in the selection of the interface on a Cyber Asset that controls the LERC. Examples include, but are not limited to, the internal (facing the low impact BES Cyber Systems) interface on an external or host-based firewall, the internal interface on a router that has implemented an access control list (ACL), or other security device. The entity also has flexibility with respect to the location of the LEAP. LEAPs are not required to reside at the asset containing the low impact BES Cyber Systems. Furthermore, the entity is not required to establish a unique physical LEAP per asset containing low impact BES Cyber Systems. Responsible Entities can have a single Cyber Asset containing multiple LEAPs that controls the LERC for more than one asset containing low impact BES Cyber Systems. Locating the Cyber Asset with multiple LEAPs at an external location with multiple assets containing low impact BES Cyber Systems “behind” it, however, should not allow uncontrolled access from one asset to all other assets sharing the LEAP.

A Cyber Asset that contains interface(s) that only perform the function of a LEAP does not meet the definition of Electronic Access Control or Monitoring System (EACMS) associated with medium or high impact BES Cyber Systems and is not subject to the requirements applicable to an EACMS. However, a Cyber Asset may contain some interfaces that function as a LEAP and other interfaces that function as an EAP for high or medium impact BES Cyber Systems. In this case, the Cyber Asset would also be subject to the requirements applicable to the EACMS associated with the medium or high impact BES Cyber Systems.

Examples of sufficient access controls may include:

- Any LERC for the asset passes through a LEAP with explicit inbound and outbound access permissions defined, or equivalent method by which both inbound and outbound connections are confined to only those that the Responsible Entity deems necessary (e.g., IP addresses, ports, or services).
- As shown in Reference Model 1 below, the low impact BES Cyber System has a host-based firewall that is controlling the inbound and outbound access. In this model, it is also possible that the host-based firewall could be on a non-BES Cyber Asset. The intent is that the host-based firewall controls the inbound and

outbound access between the low impact BES Cyber System and the Cyber Asset in the business network.

- As shown in Reference Model 5 below, a non-BES Cyber Asset has been placed between the low impact BES Cyber System on the substation network and the Cyber Asset in the business network. The expectation is that the non-BES Cyber Asset has provided a “protocol break” so that access to the low impact BES Cyber System is only from the non-BES Cyber Asset that is located within the asset containing the low impact BES Cyber System.
- Dial-up Connectivity to a low impact BES Cyber System is set to dial out only (no auto-answer) to a preprogrammed number to deliver data. Incoming Dial-up Connectivity is to a dialback modem, a modem that must be remotely controlled by the control center or control room, has some form of access control, or the low impact BES Cyber System has access control.

Some examples of situations that would lack sufficient access controls to meet the intent of this requirement include:

- An asset has Dial-up Connectivity and a low impact BES Cyber System is reachable via an auto-answer modem that connects any caller to the Cyber Asset that has a default password. There is no practical access control in this instance.
- An asset has LERC due to a BES Cyber System within it having a 3G/4G wireless card on a public carrier that allows the BES Cyber System to be reachable via a public IP address. In essence, low impact BES Cyber Systems should not be accessible from the Internet and search engines such as Shodan.
- In Reference Model 5, using just dual-homing or multiple-network interface cards in the non-BES Cyber Asset within the DMZ to provide separation between the low impact BES Cyber System and the business network would not meet the intent of “controlling” inbound and outbound electronic access assuming there was no other host-based firewall or other security device on that non-BES Cyber Asset.

The following diagrams provide reference examples to depict the rationale for identifying whether there is LERC and for implementing a LEAP. While these diagrams identify several possible configurations, Responsible Entities may have additional configurations not identified below.



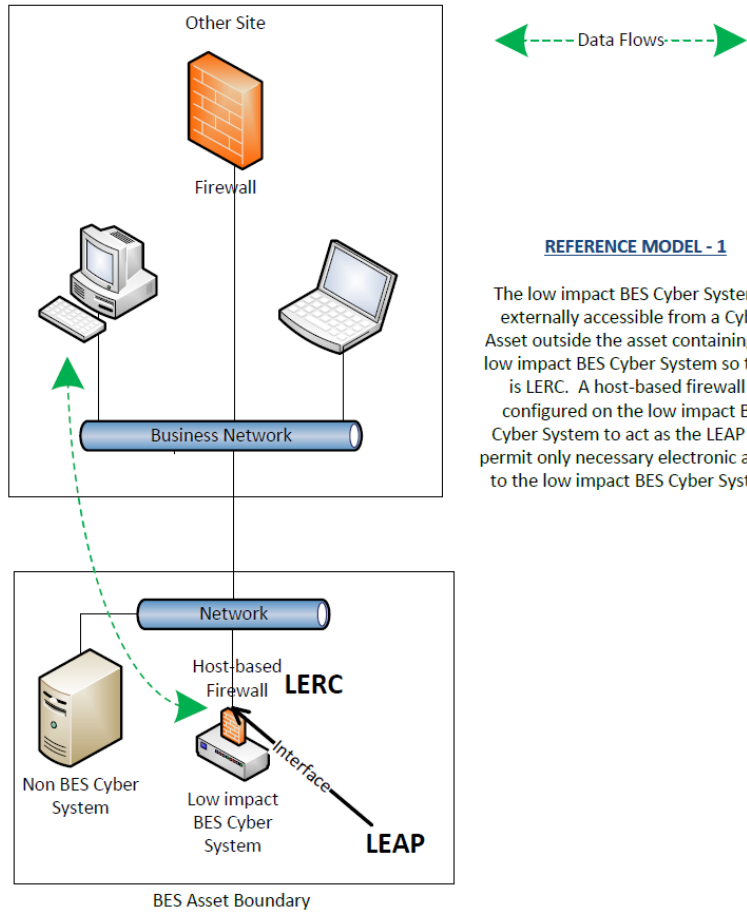

**REFERENCE MODEL - 1**

The low impact BES Cyber System is externally accessible from a Cyber Asset outside the asset containing the low impact BES Cyber System so there is LERC. A host-based firewall is configured on the low impact BES Cyber System to act as the LEAP and permit only necessary electronic access to the low impact BES Cyber System.

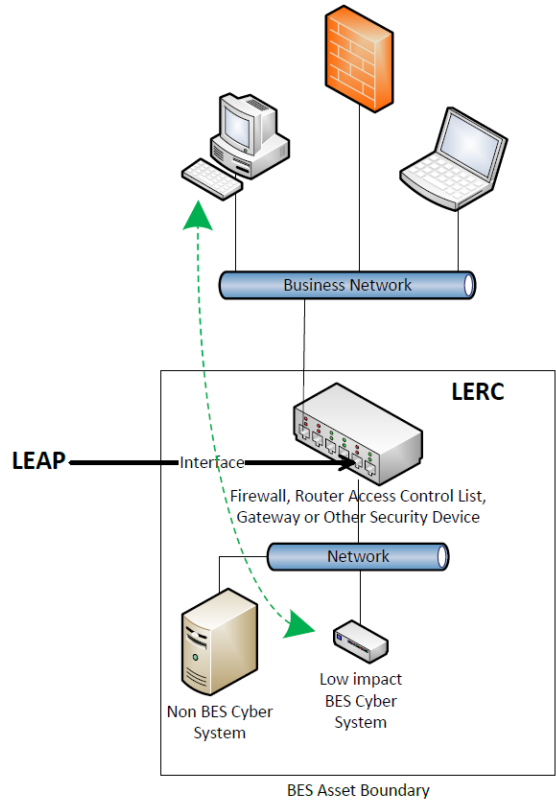

← Data Flows →

**REFERENCE MODEL - 2**

The low impact BES Cyber System is externally accessible from a Cyber Asset outside the asset containing the low impact BES Cyber System so there is LERC. A security device is placed between the business network and the low impact BES Cyber System to act as the LEAP and permit only necessary electronic access to the low impact BES Cyber System.

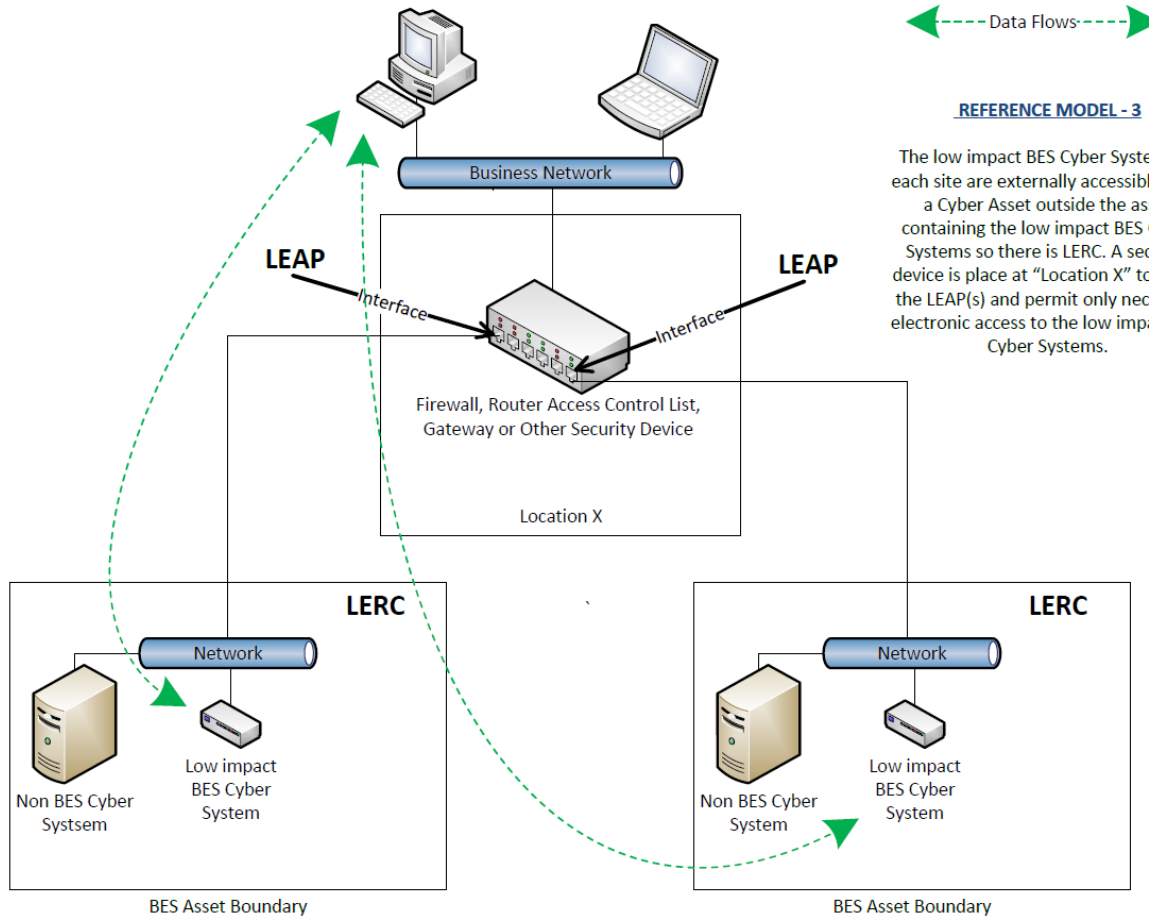

**REFERENCE MODEL - 3**

The low impact BES Cyber Systems at each site are externally accessible from a Cyber Asset outside the asset containing the low impact BES Cyber Systems so there is LERC. A security device is placed at "Location X" to act as the LEAP(s) and permit only necessary electronic access to the low impact BES Cyber Systems.

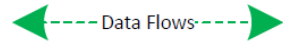
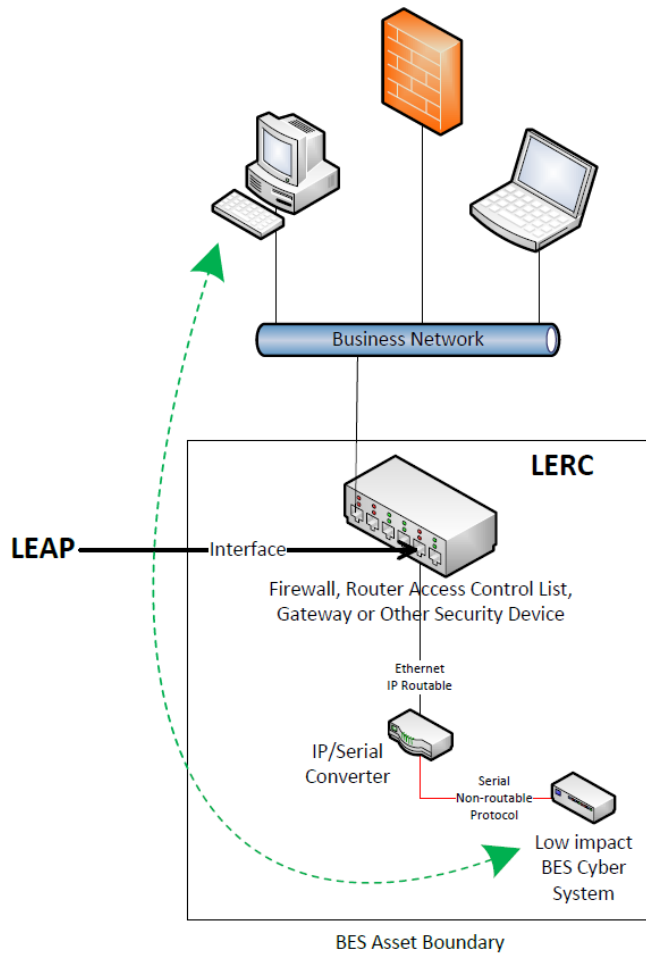

**REFERENCE MODEL - 4**

The low impact BES Cyber System is externally accessible from a Cyber Asset outside the asset containing the low impact BES Cyber System. There is LERC because the IP/Serial converter is extending the communication between the business network Cyber Asset and the low impact BES Cyber System is directly addressable from outside the asset. A security device is placed between the business network and the low impact BES Cyber System to permit only necessary electronic access to the low impact BES Cyber System.

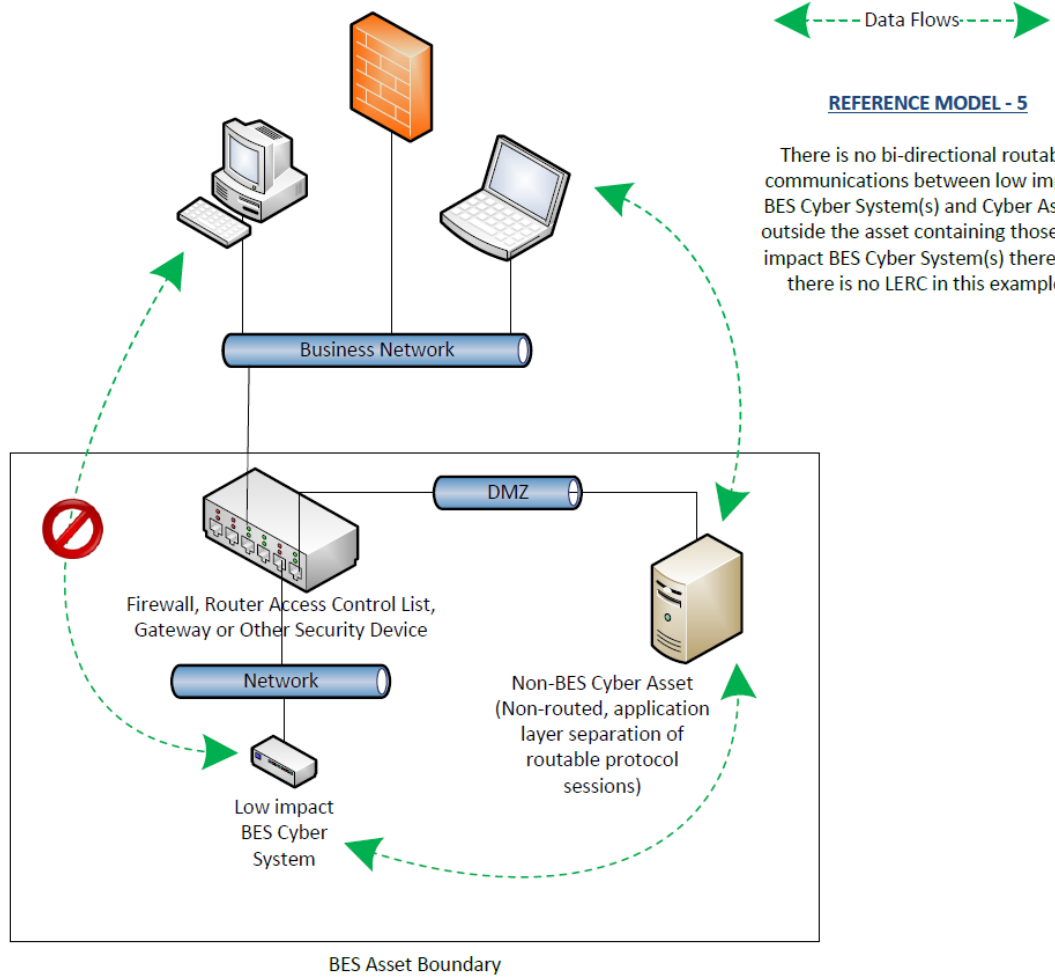

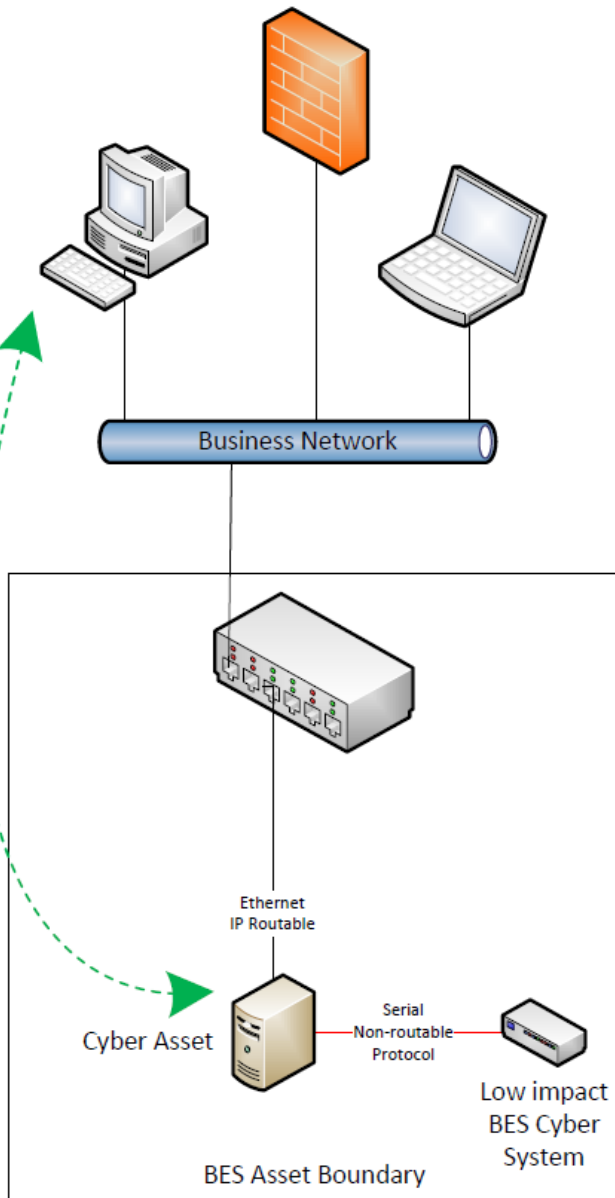

←---Data Flows---→

**REFERENCE MODEL - 6**

In this example, a Cyber Asset stops the direct access to the low impact BES Cyber System. There is a layer 7 application layer break or the Cyber Asset requires authentication and then establishes a new connection to the low impact BES Cyber System. There is no LERC in this example.

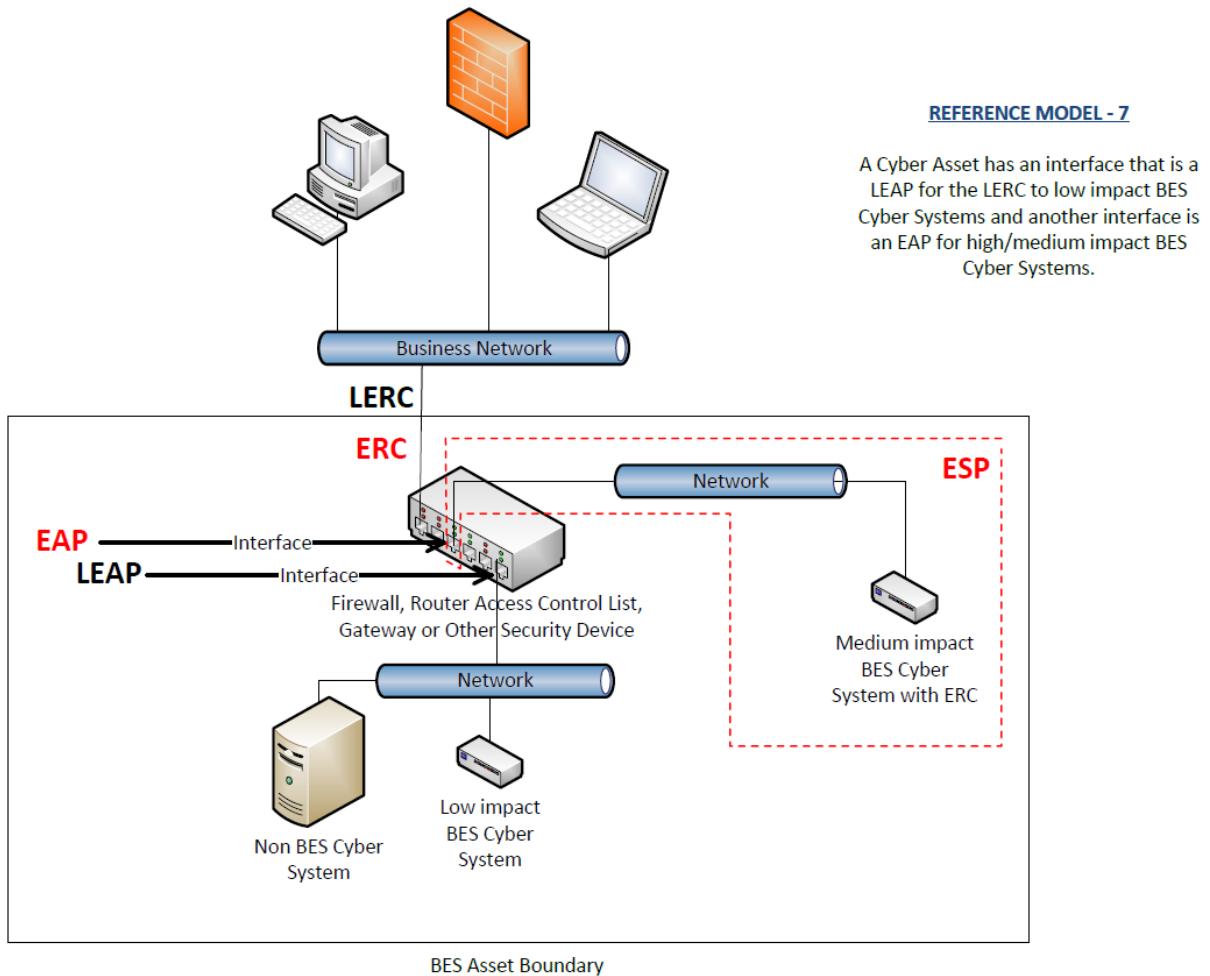

**Requirement R2, Attachment 1, Section 4 – Cyber Security Incident Response**

The entity should have one or more documented Cyber Security Incident response plan(s) that include each of the topics listed in Section 4. If, in the normal course of business, suspicious activities are noted at an asset containing low impact BES Cyber Systems, the intent is for the entity to implement a Cyber Security Incident response plan that will guide the entity in responding to the incident and reporting the incident if it rises to the level of a Reportable Cyber Security Incident.

Entities are provided the flexibility to develop their Attachment 1, Section 4 Cyber Security Incident response plan(s) by asset or group of assets. The plans do not need to be on a per asset site or per low impact BES Cyber System basis. Entities can choose to use a single enterprise-wide plan to fulfill the obligations for low impact BES Cyber Systems.

The plan(s) must be tested once every 36 months. This is not an exercise per low impact BES Cyber Asset or per type of BES Cyber Asset but rather is an exercise of each incident response plan the entity created to meet this requirement. An actual Reportable Cyber Security Incident counts as an exercise as do other forms of tabletop exercises or drills. NERC-led exercises such as GridEx participation would also count as an exercise provided the entity's response plan is followed. The intent of the requirement is for entities to keep the Cyber Security Incident response plan(s) current, which includes updating the plan(s), if needed, within 180 days following a test or an actual incident.

For low impact BES Cyber Systems, the only portion of the definition of Cyber Security Incident that would apply is, "A malicious act or suspicious event that disrupts, or was an attempt to disrupt, the operation of a BES Cyber System." The other portion of that definition is not to be used to require ESPs and PSPs for low impact BES Cyber Systems.

### **Requirement R3:**

The intent of CIP-003-7, Requirement R3 is effectively unchanged since prior versions of the standard. The specific description of the CIP Senior Manager has now been included as a defined term rather than clarified in the Reliability Standard itself to prevent any unnecessary cross-reference to this standard. It is expected that the CIP Senior Manager will play a key role in ensuring proper strategic planning, executive/board-level awareness, and overall program governance.

### **Requirement R4:**

As indicated in the rationale for CIP-003-7, Requirement R4, this requirement is intended to demonstrate a clear line of authority and ownership for security matters. The intent of the SDT was not to impose any particular organizational structure, but, rather, the intent is to afford the Responsible Entity significant flexibility to adapt this requirement to its existing organizational structure. A Responsible Entity may satisfy this requirement through a single delegation document or through multiple delegation documents. The Responsible Entity can make use of the delegation of the delegation authority itself to increase the flexibility in how this applies to its organization. In such a case, delegations may exist in numerous documentation records as long as the collection of these documentation records shows a clear line of authority back to the CIP Senior Manager. In addition, the CIP Senior Manager could also choose not to delegate any authority and meet this requirement without such delegation documentation.

The Responsible Entity must keep its documentation of the CIP Senior Manager and any delegations up-to-date. This is to ensure that individuals do not assume any undocumented authority. However, delegations do not have to be re-instated if the individual who delegated the task changes roles or the individual is replaced. For instance, assume that John Doe is named the CIP Senior Manager and he delegates a specific task to the Substation Maintenance Manager. If John Doe is replaced as the CIP Senior Manager, the CIP Senior Manager documentation must be updated within the specified timeframe, but the existing delegation to the Substation Maintenance Manager remains in effect as approved by the previous CIP Senior Manager, John Doe.