

NERC

NORTH AMERICAN ELECTRIC
RELIABILITY CORPORATION

Bulk Electric System Definition Reference Document

Version 2 | April 2014

This technical reference was created by the Definition of Bulk Electric System drafting team to assist entities in applying the definition. It should be read in concert with the complete definition, found in the [NERC Glossary of Terms](#), and any guidance issued by the ERO. The process for handling requests for exceptions to the definition is found in Appendix 5c of the NERC Rules of Procedure. Both the NERC Glossary of Terms and Rules of Procedure are posted on the [NERC website](#).

RELIABILITY | ACCOUNTABILITY



3353 Peachtree Road NE
Suite 600, North Tower
Atlanta, GA 30326
404-446-2560 | www.nerc.com

Table of Contents

| | |
|--|----|
| Table of Contents | 3 |
| Introduction..... | 4 |
| I. List of Figures | 8 |
| II. Inclusions | 10 |
| III. Exclusions..... | 27 |
| IV. Hierarchical Application of the Definition | 68 |
| V. Availability of Exception Process | 84 |
| VI. Version History..... | 85 |

Introduction

During the course of Project 2010-17 Definition of Bulk Electric System (DBES), several commenters requested that the Standard Drafting Team (SDT) create a reference document explaining how the revised definition should be applied. This document is intended to provide such a reference.

Disclaimer

This document is not an official position of NERC and will not be binding on enforcement decisions of the NERC Compliance Monitoring and Enforcement Program. This reference document reflects the professional opinion of the DBES SDT, given in good faith for illustrative purposes only.

Background

On November 18, 2010 FERC issued Order No. 743 and directed NERC to revise the definition of the Bulk Electric System (BES) so that the definition encompasses all Elements and Facilities necessary for the reliable operation and planning of the interconnected Bulk-Power System. The revisions to the definition were developed in two phases. The final revised definition was approved by the Federal Energy Regulatory Commission (FERC or the Commission) on March 20, 2014.

Purpose

The purpose of this document is to assist the industry with the application of the revised definition. Examples are provided where appropriate but should not be considered as all-inclusive. The document is intended to provide clarification and explanations for the application of the revised definition in a consistent, continent-wide basis for the majority of BES Elements.

Definition

Bulk Electric System (BES): Unless modified by the lists shown below, all Transmission Elements operated at 100 kV or higher and Real Power and Reactive Power resources connected at 100 kV or higher. This does not include facilities used in the local distribution of electric energy.

Inclusions:

- **I1** - Transformers with the primary terminal and at least one secondary terminal operated at 100 kV or higher unless excluded by application of Exclusion E1 or E3.
- **I2** – Generating resource(s) including the generator terminals through the high-side of the step-up transformer(s) connected at a voltage of 100 kV or above with:
 - Gross individual nameplate rating greater than 20 MVA. Or,
 - Gross plant/facility aggregate nameplate rating greater than 75 MVA.
- **I3** - Blackstart Resources identified in the Transmission Operator’s restoration plan.
- **I4** - Dispersed power producing resources that aggregate to a total capacity greater than 75 MVA (gross nameplate rating), and that are connected through a system designed primarily for delivering such capacity to a common point of connection at a voltage of 100 kV or above. Thus, the facilities designated as BES are:
 - The individual resources, and
 - The system designed primarily for delivering capacity from the point where those resources aggregate to greater than 75 MVA to a common point of connection at a voltage of 100 kV or above.

- **I5** –Static or dynamic devices (excluding generators) dedicated to supplying or absorbing Reactive Power that are connected at 100 kV or higher, or through a dedicated transformer with a high-side voltage of 100 kV or higher, or through a transformer that is designated in Inclusion I1 unless excluded by application of Exclusion E4.

Exclusions:

- **E1** - Radial systems: A group of contiguous transmission Elements that emanates from a single point of connection of 100 kV or higher and:
 - Only serves Load. Or,
 - Only includes generation resources, not identified in Inclusions I2, I3, or I4, with an aggregate capacity less than or equal to 75 MVA (gross nameplate rating). Or,
 - Where the radial system serves Load and includes generation resources, not identified in Inclusions I2, I3 or I4, with an aggregate capacity of non-retail generation less than or equal to 75 MVA (gross nameplate rating).

Note 1 – A normally open switching device between radial systems, as depicted on prints or one-line diagrams for example, does not affect this exclusion.

Note 2 – The presence of a contiguous loop, operated at a voltage level of 50 kV or less, between configurations being considered as radial systems, does not affect this exclusion.

- **E2** - A generating unit or multiple generating units on the customer's side of the retail meter that serve all or part of the retail Load with electric energy if: (i) the net capacity provided to the BES does not exceed 75 MVA, and (ii) standby, back-up, and maintenance power services are provided to the generating unit or multiple generating units or to the retail Load by a Balancing Authority, or provided pursuant to a binding obligation with a Generator Owner or Generator Operator, or under terms approved by the applicable regulatory authority.
- **E3** - Local networks (LN): A group of contiguous transmission Elements operated at less than 300 kV that distribute power to Load rather than transfer bulk power across the interconnected system. LN's emanate from multiple points of connection at 100 kV or higher to improve the level of service to retail customers and not to accommodate bulk power transfer across the interconnected system. The LN is characterized by all of the following:
 - Limits on connected generation: The LN and its underlying Elements do not include generation resources identified in Inclusions I2, I3, or I4 and do not have an aggregate capacity of non-retail generation greater than 75 MVA (gross nameplate rating);
 - Real Power flows only into the LN and the LN does not transfer energy originating outside the LN for delivery through the LN; and
 - Not part of a Flowgate or transfer path: The LN does not contain any part of a permanent Flowgate in the Eastern Interconnection, a major transfer path within the Western Interconnection, or a comparable monitored Facility in the ERCOT or Quebec Interconnections, and is not a monitored Facility included in an Interconnection Reliability Operating Limit (IROL).
- **E4** – Reactive Power devices installed for the sole benefit of a retail customer(s).

Note - Elements may be included or excluded on a case-by-case basis through the Rules of Procedure exception process.

Summary

An understanding of the core definition and each Inclusion and Exclusion is necessary to accurately and consistently apply the BES definition. (It should be noted that the BES definition applies to AC and DC electrical facilities.) The application of the 'bright-line' BES definition is a three-step process that, when appropriately applied, will identify the vast majority of BES Elements in a consistent manner that can be applied on a continent-wide basis.

FERC Order No. 773 directed implementation of the revised BES definition to take into account the impact of sub-100 kV looped Facilities regardless of voltage level. This altered previous guidance on the evaluation of radial systems. The drafting team developed a technical justification setting a threshold of 50 kV as the value where looped facilities had potential impact on the BES, i.e., if a looped Facility was below 50 kV, an entity could still apply Exclusion E1 as it was shown that looped facilities below 50 kV had no impact on the reliability of the BES. Configurations as shown in the diagrams dealing with the radial system and local network exclusions as well as the system diagrams reflect this finding.

STEP 1: CORE DEFINITION: The core definition is used to establish the bright-line of 100 kV, the overall demarcation point between BES and non-BES Elements. The core BES definition identifies the Real Power and Reactive Power resources connected at 100 kV or higher, as included in the BES. To fully appreciate the scope of the core definition, an understanding of the term "Element" is needed. "Element" is defined in the NERC Glossary as: "Any electrical device with terminals that may be connected to other electrical devices such as a generator, transformer, circuit breaker, bus section, or transmission line. An element may be comprised of one or more components."

STEP 2: INCLUSIONS: This step involves applying the specific Inclusions, provides additional clarification for the purposes of identifying specific Elements that are included in the BES. The Inclusions address Transmission Elements and Real Power and Reactive Power resources with specific criteria to provide for a consistent determination of whether an Element is classified as BES or non-BES. There are five Inclusions in the Definition. The facilities described in Inclusions I1, I2, I4 and I5 are each operated (if transformers – Inclusion I1) or connected (if generating resources, dispersed power producing resources or Reactive Power resources – Inclusions I2, I4 and I5) at or above the 100 kV threshold. Inclusion I3 encompasses Blackstart Resources identified in a Transmission Operator's restoration plan, which are necessary for the reliable operation of the interconnection transmission system and should be included in the BES regardless of their size (MVA) or the voltage at which they are connected.

STEP 3: EXCLUSIONS: This step evaluates specific situations for potential exclusion from the BES. The exclusion language is written to specifically identify Elements or groups of Elements for exclusion from the BES. Step three (3) should be applied in the following sequence:

Exclusion E2 (Behind-the-Meter Generation) provides for the specific exclusion of certain Real Power resources that reside behind-the-retail meter (on the customer's side) and supersedes the more general Inclusion I2 (Generating Resources). Behind-the-meter generation that meets these specific criteria do not affect reliability of the BES because the net capacity supplied to the BES is less than 75 MVA and the specific criteria impose obligations to support reliability when the resources are unavailable.

Exclusion E4 (Reactive Power Devices) provides for the specific exclusion of Reactive Power devices installed for the sole benefit of a retail customer(s) and supersedes the more general Inclusion I5 (Static or Dynamic Reactive Power Devices). Reactive Power devices installed for the sole benefit of a retail customer are, by definition, not required for operation of the interconnected transmission system.

Exclusion E3 (Local Networks) provides for the exclusion of local networks that meet the specific criteria identified in the exclusion language. Exclusion E3 does not allow for the exclusion of Real Power and Reactive Power resources captured by Inclusions I2 through I5. In instances where a transformer (under Inclusion I1) is an Element of a local network (under Exclusion E3), the transformer would be excluded pursuant to Exclusion E3. Exclusion E3 may not be used to exclude transmission Elements (captured by the core definition and Inclusion I1) when Real Power resources are present that are captured by Inclusion I2, I3, or I4. This assures that interconnection facilities for BES generators are not excluded.

Exclusion E1 (Radial Systems) provides for the exclusion of transmission Elements from radial systems that meet the specific criteria identified in the exclusion language. Exclusion E1 does not allow for the exclusion of Real Power and Reactive Power resources captured by Inclusions I2 through I5. In instances where a transformer (under Inclusion I1) is an Element of a radial system (under Exclusion E1), the transformer would be excluded pursuant to Exclusion E1. Exclusion E1 may not be used to exclude transmission Elements (captured by the core definition and Inclusion I1) when Real Power resources are present that are captured by Inclusion I2, I3, or I4. This assures that interconnection facilities for BES generators are not excluded.

This Reference Document has been divided into sections to accurately illustrate how specific parts of the definition are applied, and then how the hierarchal application of the definition is accomplished. Section I is a list of figures. Sections II and III provide illustrative diagrams with accompanying text, where appropriate, describing the application of the BES definition, grouped according to the specific inclusion or exclusion. Section IV provides a series of system diagrams that depict the hierarchical application of the definition. Section V establishes the linkage to the Rules of Procedure Exception Process.

I. List of Figures

| | |
|---|----|
| Figure I1-1: Typical Two Winding Transformer (BES) | 11 |
| Figure I1-2: Typical Three Winding Transformer (BES) | 11 |
| Figure I1-3: Typical Two Winding Transformer (non-BES) | 11 |
| Figure I1-4: Typical Three Winding Transformer (non-BES) | 12 |
| Figure I2-1: Single Generator (BES) | 13 |
| Figure I2-2: Single Generator (non-BES)..... | 14 |
| Figure I2-3: Multiple Generators at a Single Site (BES) | 15 |
| Figure I2-4: Multiple Generators at a Single Site (BES & non-BES) | 16 |
| Figure I2-5: Multiple Generators at a Single Site (BES) | 17 |
| Figure I2-6: Multiple Generators at a Single Site (BES & non-BES) | 18 |
| Figure I4-1: Dispersed Generation Site (Single Voltage Transformation) – Wind Farm..... | 21 |
| Figure I4-2: Dispersed Generation Site (Unknown Collector System Configuration) – Wind Farm..... | 22 |
| Figure I4-3: Dispersed Generation Site (Single Voltage Transformation) – Solar Array..... | 23 |
| Figure I4-4: Dispersed Generation Site (Multiple Voltage Transformations) – Solar Array..... | 24 |
| Figure I5-1: Reactive Resources (BES & non-BES) | 26 |
| Figure E1-1: Radial System: Serving Only Load | 31 |
| Figure E1-2: Multiple Radial Systems (Underlying Loop Facilities < 50 kV)..... | 32 |
| Figure E1-3: Impact of Sub-100 kV Looped Facilities | 33 |
| Figure E1-4: Radial System: Single BES Generation Resource | 34 |
| Figure E1-5: Radial System: Single non-BES Generation Resource | 35 |
| Figure E1-6: Radial System: Blackstart Resource | 36 |
| Figure E1-7: Radial System: Multiple (BES & non-BES) Generation Resources (Non-Retail) | 37 |
| Figure E1-8: Radial System: Multiple (non-BES) Generation Resources (Non-Retail)..... | 38 |
| Figure E1-9: Radial System: Multiple (non-BES) Generation Resources (Non-Retail)..... | 39 |
| Figure E1-10: Radial System: Multiple (non-BES) Generation Resources (Retail & Non-Retail) | 40 |
| Figure E1-11: Radial System: Generation Resource (Non-Retail) & Serving Load | 41 |
| Figure E1-12: Radial System: Generation Resource (Non-Retail) & Serving Load | 42 |
| Figure E1-13: Radial System: Generation Resource (Non-Retail) & Serving Load | 43 |
| Figure E1-14: Radial System: Generation Resource (Non-Retail) & Serving Load | 44 |
| Figure E1-15: Radial System: Generation Resource (Retail & Non-Retail) & Serving Load..... | 45 |
| Figure E1-16: Radial System: Normally Open Switching Device between Load Serving Radial Systems | 46 |
| Figure E1-17: Radial System: Normally Open Switching Device between Load Serving Radial Systems with a < 50 kV Loop..... | 48 |
| Figure E1-18: Impact of Sub-100 kV Looped Facilities (Switching Devices Identified N.O. > 100 kV & N.C. < 100 kV & > 50 kV) | 49 |

| | |
|--|----|
| Figure E1-19: Radial System: Normally Closed Switching Device (> 100 kV) between Load Serving Radial Systems with a < 50 kV Loop | 50 |
| Figure E1-20: Impact of Sub-100 kV Looped Facilities (Switching Devices Identified N.C. > 100 kV & N.C. < 100 kV & > 50 kV) | 51 |
| Figure E2-1: Behind-the-Meter Generation: Net Capacity to the BES Less Than 75 MVA..... | 53 |
| Figure E2-2: Behind-the-Meter Generation: Net Capacity to the BES Greater Than 75 MVA | 54 |
| Figure E3-1: Local Network (non-BES) with Retail & Non-Retail Generation Resources & Serving Load | 57 |
| Figure E3-2: Local Network (BES) with Retail & Non-Retail Generation Resources & Serving Load..... | 58 |
| Figure E3-3: Local Network (BES) with Retail & Non-Retail Generation Resources & Serving Load..... | 59 |
| Figure E3-4: Local Network (non-BES) with Sub-100 kV Loop..... | 61 |
| Figure E3-5: Local Network (BES) with Sub-100 kV Loop | 62 |
| Figure E3-6: Local Network (non-BES) with Sub-100 kV Looped Facilities (Switching Devices Identified: N.O. > 100 kV & N.C. < 100 kV/> 50 kV) | 63 |
| Figure E3-7: Local Network (BES) with Sub-100 kV Looped Facilities (Switching Devices Identified: N.O. > 100 kV & N.C. < 100 kV/< 50 kV) | 64 |
| Figure E3-8: Local Network (non-BES) with Sub-100 kV Looped Facilities (Switching Devices Identified: N.C. > 100 kV & N.C. < 100 kV/> 50 kV) | 65 |
| Figure E3-9: Local Network (BES) with Sub-100 kV Looped Facilities (Switching Devices Identified: N.C. > 100 kV & N.C. < 100 kV/> 50 kV)..... | 66 |
| Figure S1-1: System Diagram – Base Diagram..... | 70 |
| Figure S1-2: System Diagram – Assumptions | 71 |
| Figure S1-3: System Diagram – Application of ‘Core’ Definition..... | 72 |
| Figure S1-4: System Diagram – Application of Inclusion I1 | 73 |
| Figure S1-5: System Diagram – Application of Inclusion I2 | 74 |
| Figure S1-6: System Diagram – Application of Inclusion I3 | 75 |
| Figure S1-7: System Diagram – Application of ‘Core’ Definition & Inclusions | 76 |
| Figure S1-8: System Diagram – Application of Exclusion E2..... | 77 |
| Figure S1-9: System Diagram – Application of Exclusion E3..... | 78 |
| Figure S1-9a: System Diagram – Application of Exclusion E3 (Embedded Local Network)..... | 79 |
| Figure S1-9b: System Diagram – Application of Exclusion E3 (Embedded Radial Systems)..... | 80 |
| Figure S1-10: System Diagram – Application of Exclusion E1 (Part 1)..... | 81 |
| Figure S1-10a: System Diagram – Application of Exclusion E1 (Part 2)..... | 82 |
| Figure S1-11: System Diagram – Full Application of BES Definition | 83 |

II. Inclusions

Each inclusion is shown below with both text and diagrams explaining how to apply the BES definition for the specific configuration shown. These examples are not to be considered all-inclusive, and simply reflect the professional opinion of the DBES SDT and are provided in good faith for illustrative purposes only. This document is not an official position of NERC and will not be binding on enforcement decisions of the NERC Compliance Monitoring and Enforcement Program.

The section on Inclusion I3 does not include diagrams, as there are no application configuration issues associated with it. Blackstart Resources are included in the BES regardless of configuration or location.

Diagrams only show application of the definition to the specific Element in question. For example, in Figure I1-1 below, only the windings of the transformer are shown as being included in the BES. The lines coming out of the transformer are not delineated as BES or non-BES, as no assumptions are being made as to where and how those lines connect in the big picture.

Key to diagram color coding:

- **Blue** indicates that an Element is included in the BES
- **Green** indicates that an Element is not included in the BES
- **Orange** indicates 'points of connection'
- **Black** indicates Elements that are not evaluated for the specific inclusion depicted in the individual diagrams being shown

II.1 BES Inclusion I1

I1. Transformers with the primary terminal and at least one secondary terminal operated at 100 kV or higher unless excluded under Exclusion E1 [radial] or E3 [local network].

Note: Figures I1-1 through I1-4 are depictions of the application of Inclusion I1 and are intended to assist the user during the hierarchical application of the BES definition.

Figures I1-1 through I1-4 depict various types of transformers and operating configurations typically utilized in the electric utility industry.

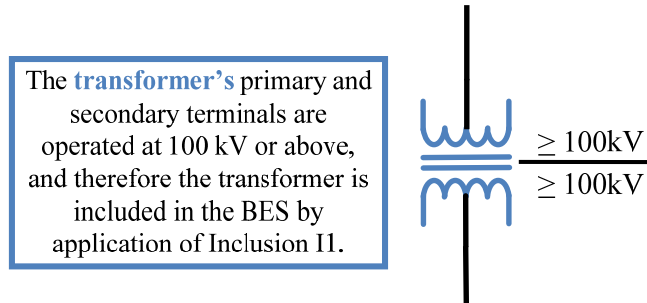

Figure I1-1: Typical Two Winding Transformer (BES)

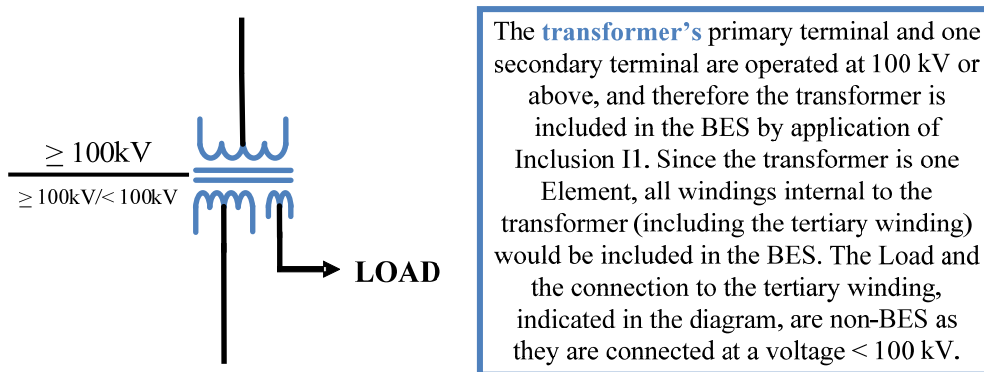

Figure I1-2: Typical Three Winding Transformer (BES)

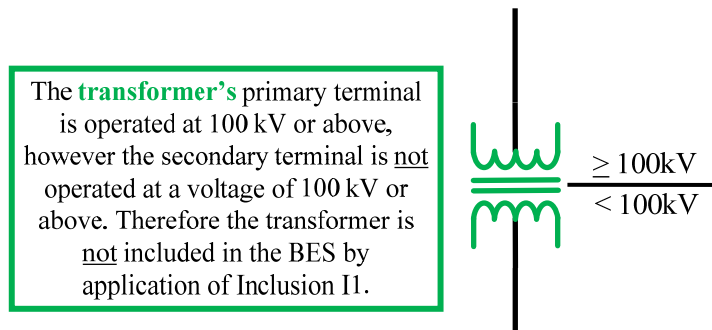

Figure I1-3: Typical Two Winding Transformer (non-BES)

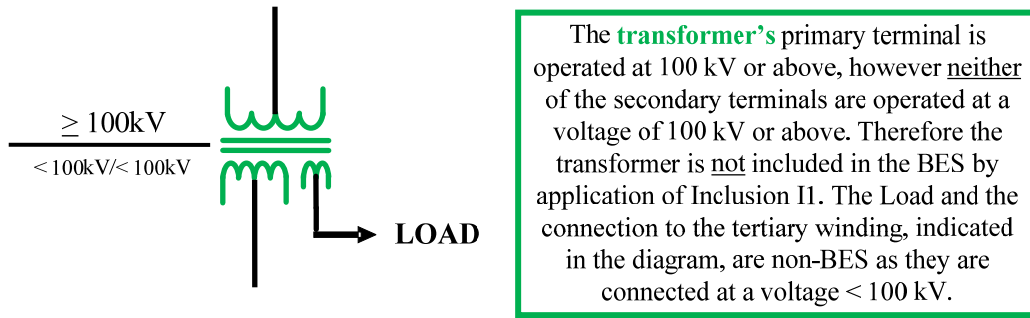

Figure I1-4: Typical Three Winding Transformer (non-BES)

11.2 BES Inclusion I2

12. Generating resource(s) including the generator terminals through the high-side of the step-up transformer(s) connected at a voltage of 100 kV or above with:
- a) Gross individual nameplate rating greater than 20 MVA. Or,
 - b) Gross plant/facility aggregate nameplate rating greater than 75 MVA.

Note: Figures I2-1 through I2-6 are depictions of the application of Inclusion I2 and are intended to assist the user during the hierarchical application of the BES definition.

Interpretation of the “or” statement in the inclusion definition is a hierarchical operator that has several steps as shown in the following diagrams.

The presence of a system service, a station service, or a generator auxiliary transformer does not affect the application of Inclusion I2. Transformers associated with system service, station service, or generator auxiliaries are evaluated under the core definition and Inclusion I1.

Figure I2-1 depicts a single generator with gross individual nameplate rating greater than 20 MVA connected through the high-side of the step-up transformer connected at a voltage of 100 kV or above. By application of Inclusion I2, this generator is identified as a BES Element.

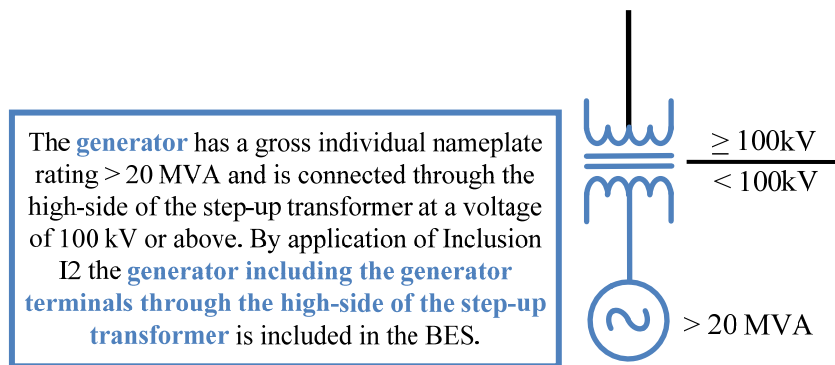

Figure I2-1: Single Generator (BES)

Figure I2-2 depicts a single generator with gross individual nameplate rating less than 20 MVA connected through the high-side of the step-up transformer connected at a voltage of 100 kV or above. By application of I2, this generator is not a BES Element.

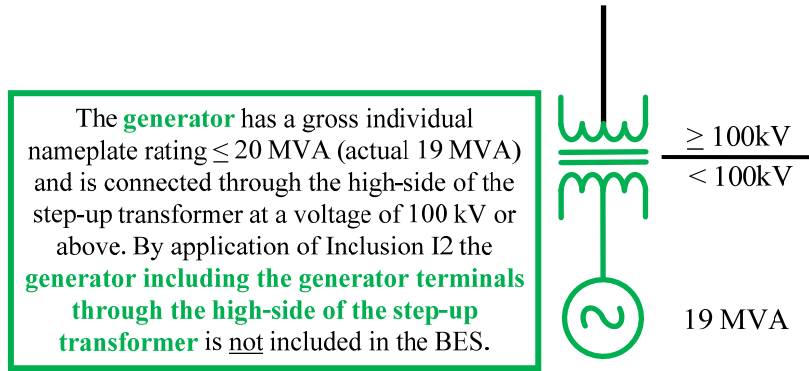
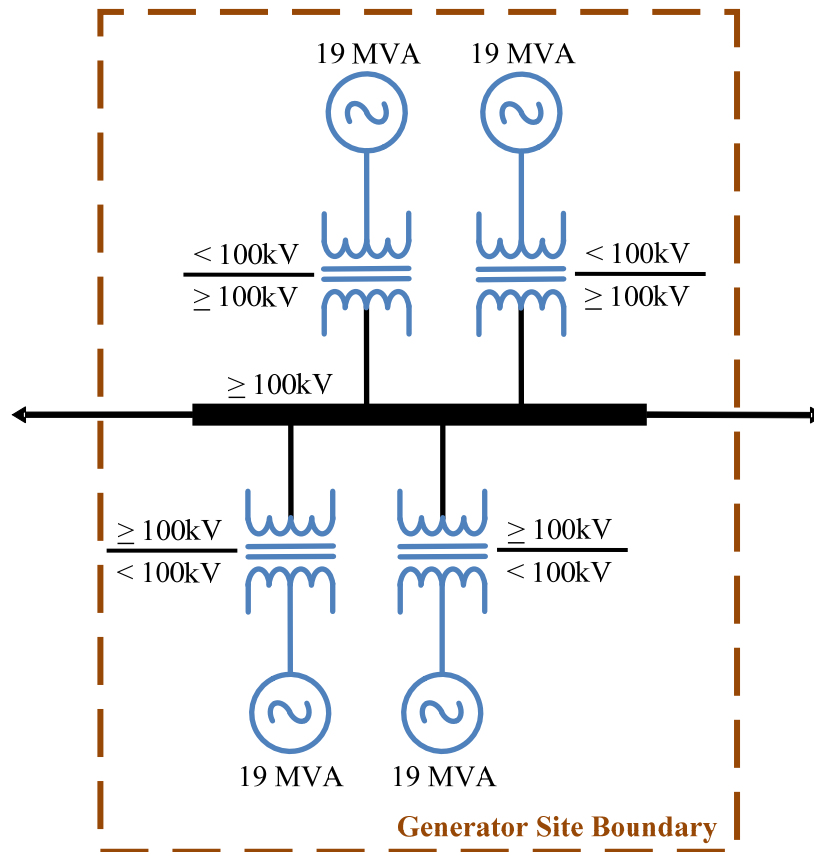

Figure I2-2: Single Generator (non-BES)

Figure I2-3 depicts a site with multiple generators connected through the high-side of the step-up transformer(s) at a voltage of 100 kV or above with a gross aggregate nameplate rating (connected @100 kV or above) greater than 75 MVA; therefore, by application of Inclusion I2, all of the generators (connected @100 kV or above) are included in the BES.



The generation site has generation with a gross aggregate nameplate rating of 76 MVA connected through the high-side of the step-up transformers at a voltage of 100 kV or above. By application of Inclusion I2, the **generators including the generator terminals through the high-side of the step-up transformers** are included in the BES.

Figure I2-3: Multiple Generators at a Single Site (BES)

Figure I2-4 depicts a site with multiple generators connected through the high-side of the step-up transformer(s) at a voltage of 100 kV or above with an aggregate nameplate rating (connected @100 kV or above) less than 75 MVA. By application of Inclusion I2, only those generators with a gross nameplate rating greater than 20 MVA connected through the high-side of the step-up transformer(s) at a voltage of 100 kV or above are included in the BES.

The **generation site** has generation with a gross aggregate nameplate rating of 70 MVA connected through the high-side of the step-up transformers at a voltage of 100 kV or above. By the application of Inclusion I2, the **generation site** is not included in the BES. (See below for detailed analysis of the individual generators.)

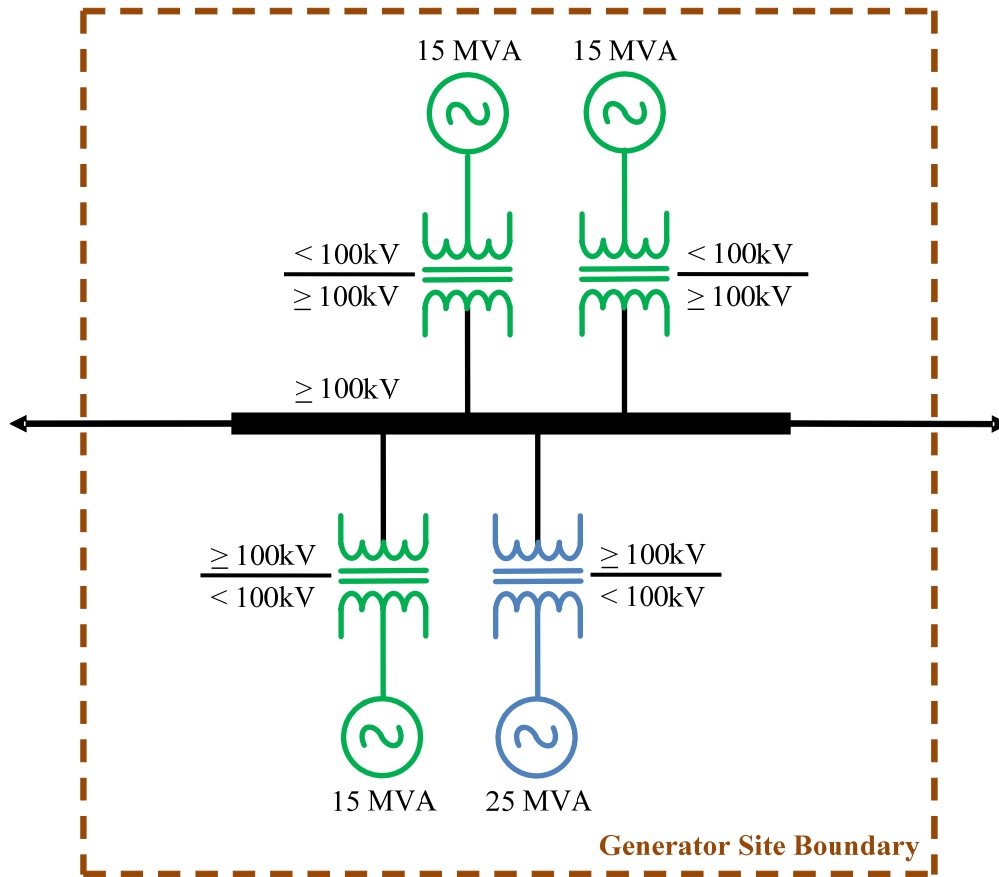

The **generators** have gross individual nameplate ratings ≤ 20 MVA (actual 15 MVA) and are connected through the high-side of the step-up transformers at a voltage of 100 kV or above. By application of Inclusion I2 these **generators including the generator terminals through the high-side of the step-up transformer** are not included in the BES.

The **generator** has a gross individual nameplate rating > 20 MVA (actual 25 MVA) and is connected through the high-side of the step-up transformer at a voltage of 100 kV or above. By application of Inclusion I2 the **generator including the generator terminals through the high-side of the step-up transformer** is included in the BES.

Figure I2-4: Multiple Generators at a Single Site (BES & non-BES)

Figure I2-5 depicts a site with multiple generators connected through the high-side of the step-up transformer(s) at a voltage of 100 kV or above with a gross aggregate nameplate rating (connected @100 kV or above) greater than 75 MVA. By application of Inclusion I2, all of these generators (connected @100 kV or above) are included in the BES. In accordance with Inclusion I2, the generators, including the generator terminals through the multiple step-up transformers with a high-side connection voltage of 100 kV or above, are considered to be a single BES Element. The step-up transformers and the interconnecting bus work are installed for the purpose of stepping-up the voltage output of the generator to a voltage of 100 kV or above.

The **generation site** has generation with a gross aggregate nameplate rating greater than 75 MVA (actual 79 MVA) connected through the high-side of the step-up transformers at a voltage of 100 kV or above. By the application of Inclusion I2, the **generation site** is included in the BES.

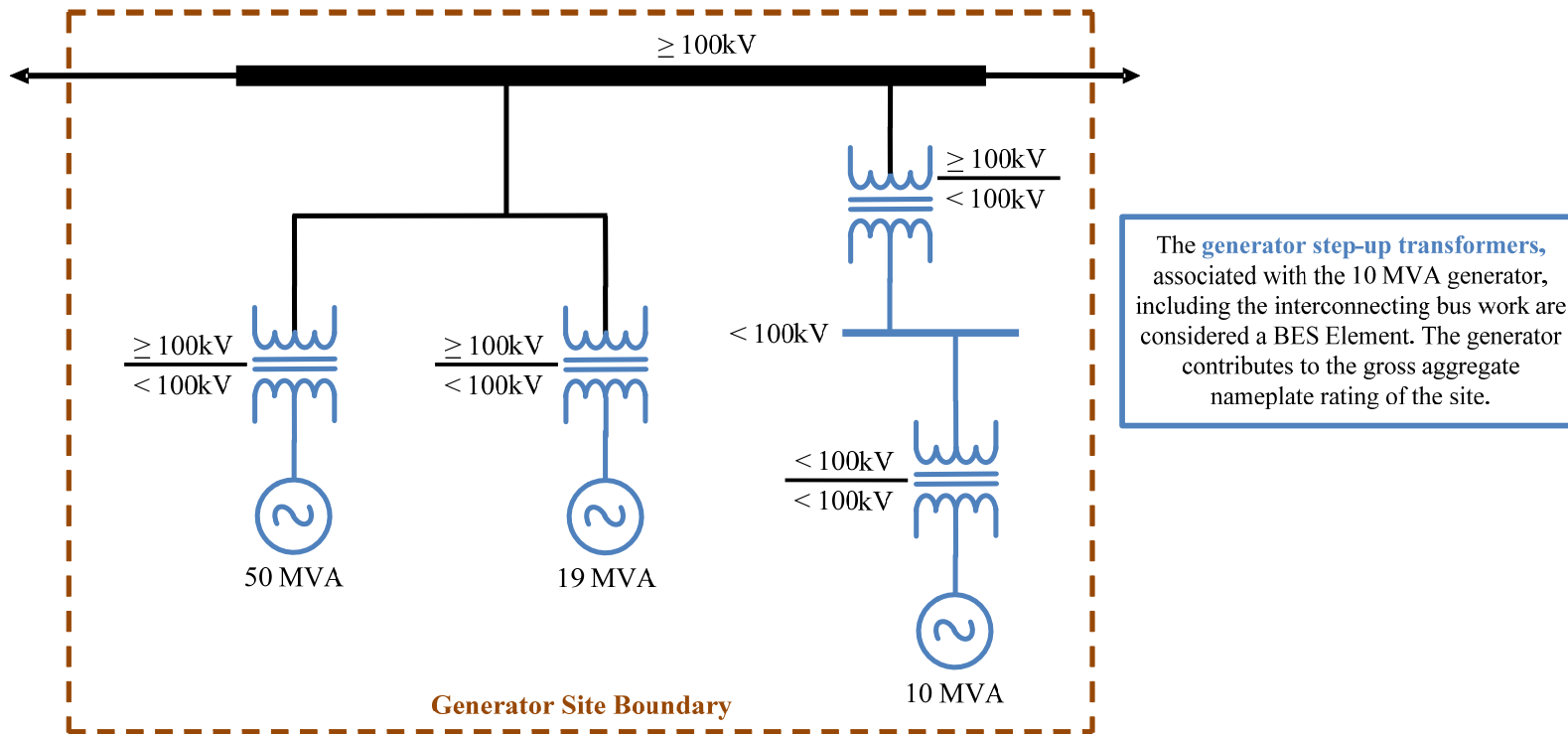

The **generator step-up transformers**, associated with the 10 MVA generator, including the interconnecting bus work are considered a BES Element. The generator contributes to the gross aggregate nameplate rating of the site.

Figure I2-5: Multiple Generators at a Single Site (BES)

Figure I2-6 depicts a site with multiple generators connected through the high side of the step-up transformer(s) at a voltage of 100 kV or above with a gross aggregate nameplate rating (connected @100 kV or above) less than 75 MVA. Therefore, only the generators that meet the single unit inclusion criteria of gross nameplate rating of greater than 20 MVA are included in the BES. The generator with the 25 MVA gross individual nameplate rating is not included in the BES or in the generation site total because the step-up transformers and the interconnecting bus work are installed for the purpose of serving Load. The NERC Glossary of Terms Used in NERC Reliability Standards defines Load as “an end-use device or customer that receives power from the electric system”.

The **generation site** has generation with a gross aggregate nameplate rating of less than 75 MVA (actual 69 MVA (50 + 19 MVA)) connected through the high-side of the step-up transformers at a voltage of 100 kV or above. The 25 MVA generator is not included in the gross aggregate calculation, see textbox on right. By the application of Inclusion I2, the **generation site** is not included in the BES.

The **generator** has a gross individual nameplate rating > 20 MVA (actual 50 MVA) and is connected through the high-side of the step-up transformer at a voltage of 100 kV or above. By application of Inclusion I2 this **generator including the generator terminals through the high-side of the step-up transformer** is included in the BES.

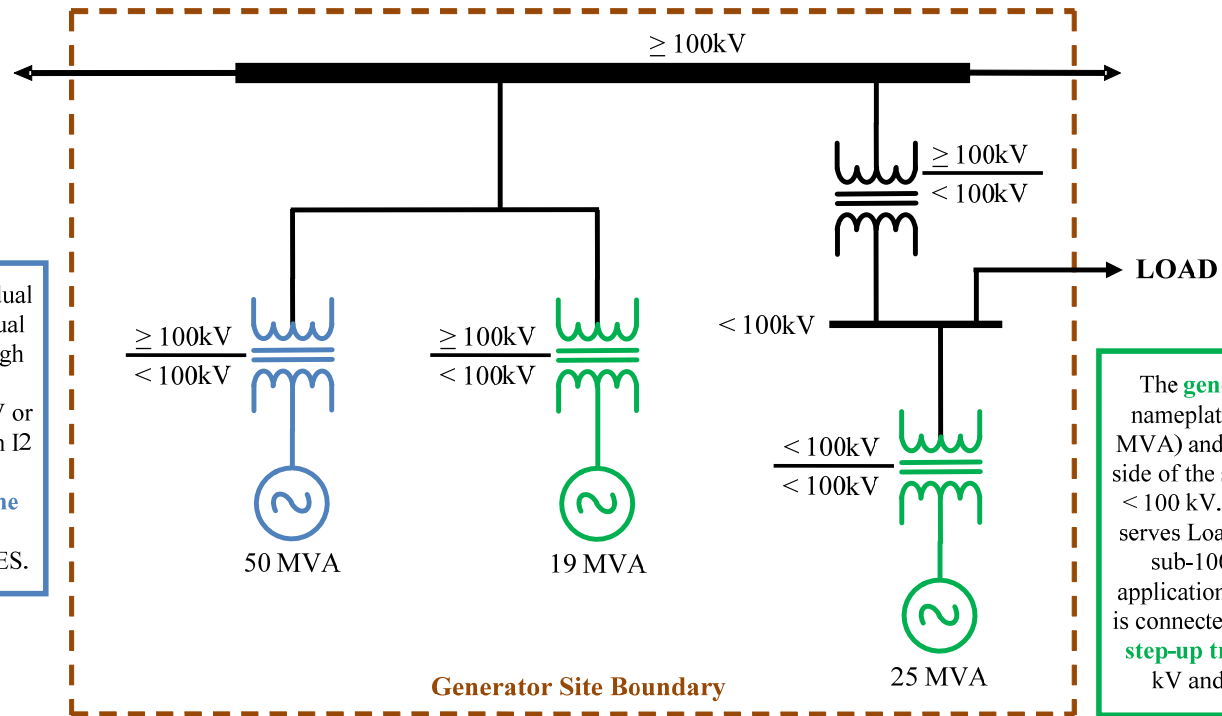

The **generator** has a gross individual nameplate rating > 20 MVA (actual 25 MVA) and is connected through the high-side of the step-up transformer at a voltage < 100 kV. The interconnecting bus work serves Load and provides a connection to sub-100 kV Facilities, therefore by application of Inclusion I2, the **generator** is connected **through the high-side of the step-up transformer** at a voltage < 100 kV and is not included in the BES.

Figure I2-6: Multiple Generators at a Single Site (BES & non-BES)

II.3 BES Inclusion I3

I3. Blackstart Resources identified in the Transmission Operator’s restoration plan.

Inclusion I3 includes Blackstart Resources identified in the Transmission Operator’s restoration plan. Blackstart Resources are included in the BES regardless of configuration or location.

The NERC Glossary of Terms Used in NERC Reliability Standards defines Blackstart Resource as follows:

“A generating unit(s) and its associated set of equipment which has the ability to be started without support from the System or is designed to remain energized without connection to the remainder of the System, with the ability to energize a bus, meeting the Transmission Operator’s restoration plan needs for real and reactive power capability, frequency and voltage control, and that has been included in the Transmission Operator’s restoration plan.”

The Transmission Operator’s restoration plan refers to the restoration plan identified in Reliability Standard EOP-005 System Restoration from Blackstart Resources.

Figures were not specifically developed for Inclusion I3 due to the simplicity of the language in the inclusion. In Section IV: Hierarchical Application of the Definition, the system diagrams include a Blackstart Resource example.

II.4 BES Inclusion I4

I4. Dispersed power producing resources that aggregate to a total capacity greater than 75 MVA (gross nameplate rating), and that are connected through a system designed primarily for delivering such capacity to a common point of connection at a voltage of 100 kV or above. Thus, the facilities designated as BES are:

- The individual resources, and
- The system designed primarily for delivering capacity from the point where those resources aggregate to greater than 75 MVA to a common point of connection at a voltage of 100 kV or above.

Note: Figures I4-1 through I4-4 are depictions of the application of Inclusion I4 and are intended to assist the user during the hierarchical application of the BES definition.

Dispersed power producing resources are small-scale power generation technologies using a system designed primarily for aggregating capacity providing an alternative to, or an enhancement of, the traditional electric power system. Examples could include but are not limited to: solar, geothermal, energy storage, flywheels, wind, micro-turbines, and fuel cells.

Common Point of Connection

The common point of connection is where the individual transmission Element(s) of the collector system is connected to the 100 kV or higher Transmission system. (Note: This point is typically specified in the respective Transmission Owner and Generator Operator Interconnection Agreements.)

Collector Systems

FERC Orders No. 773 and 773-A identified a concern that the Commission expressed regarding dispersed power collector systems. The SDT has addressed collector systems in a clear fashion that leaves no room for arbitrary determinations and eliminates the unintended consequences of categorically including as part of the BES, assets that may include local distribution facilities.

The basis of this determination takes into account the significant differences in collector system configurations that exist today that do not lend themselves to a continent-wide bright-line determination. This resulted in properly identifying the portions of the collector system which consistently provide a reliability benefit to the interconnected transmission network. The result identifies the point of aggregation of 75 MVA and above and the interconnecting facilities to the interconnected transmission network. The aggregation threshold is consistent with the aggregation of capacity in Inclusion I4 and recognizes that the loss of those facilities result in a loss of 75 MVA capacity or greater to the BES.

Figure I4-1 depicts a dispersed generation site and substation design with a single transformation of voltage.

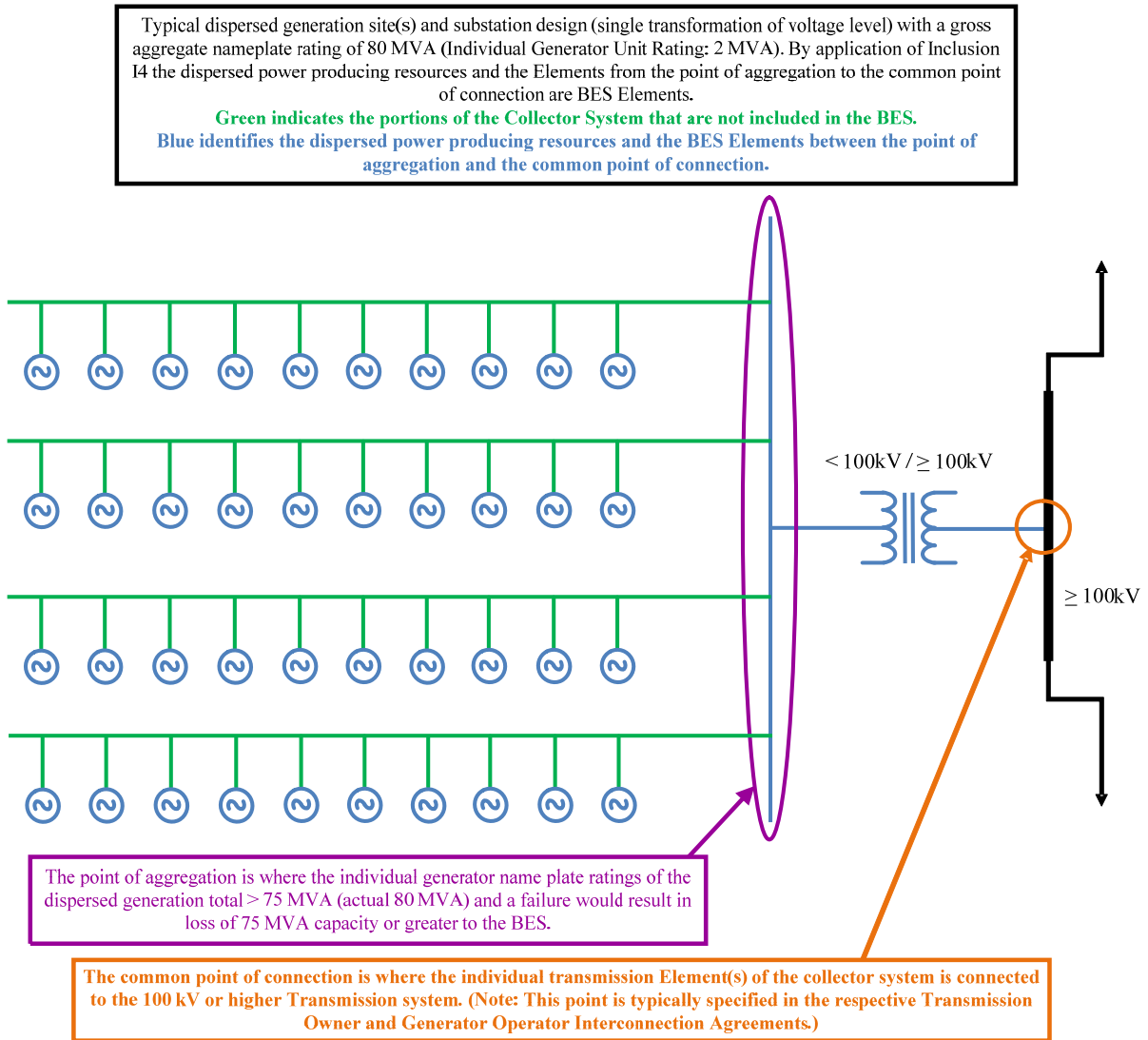

Figure I4-1: Dispersed Generation Site (Single Voltage Transformation) – Wind Farm

Figure I4-2 depicts a dispersed generation site and substation design with unknown collector system configuration.

Typical dispersed generation site and substation design (single transformation of voltage level) with a gross aggregate nameplate rating of 80 MVA (Individual Generator Unit Rating: 2 MVA). By application of Inclusion I4 the dispersed power producing resources and the Elements from the point of aggregation to the common point connection are BES Elements.

Green indicates the portions of the Collector System that are not included in the BES.

Blue identifies the dispersed power producing resources and BES Elements between the point where those resources aggregate to greater than 75 MVA to a common point of connection at a voltage of 100 kV or above.

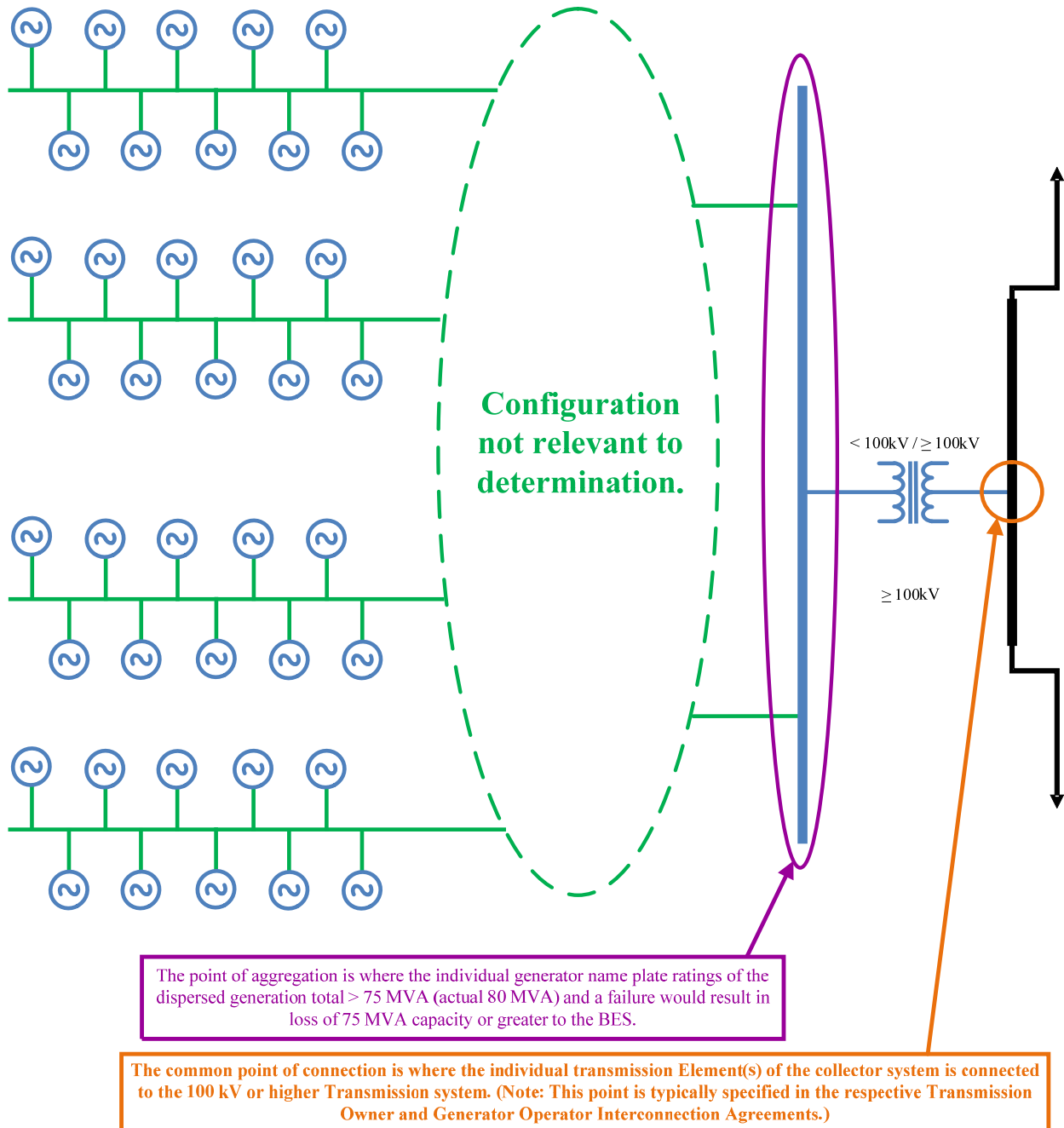

Figure I4-2: Dispersed Generation Site (Unknown Collector System Configuration) – Wind Farm

Figure I4-3 depicts a dispersed generation site and substation design with a single transformation of voltage.

Dispersed generation site and substation design (single transformation of voltage level) with a gross aggregate nameplate rating of 80 MVA (Individual Photovoltaic Bank Rating: 20 MVA). By application of Inclusion I4 the Photovoltaic Cells & Inverters (generators) are included in the BES.

Green indicates the portions of the Collector System that are not included in the BES.

Blue identifies BES dispersed power producing resources (Photovoltaic Cells & Inverters) and the BES Elements between the point of aggregation and the common point of connection.

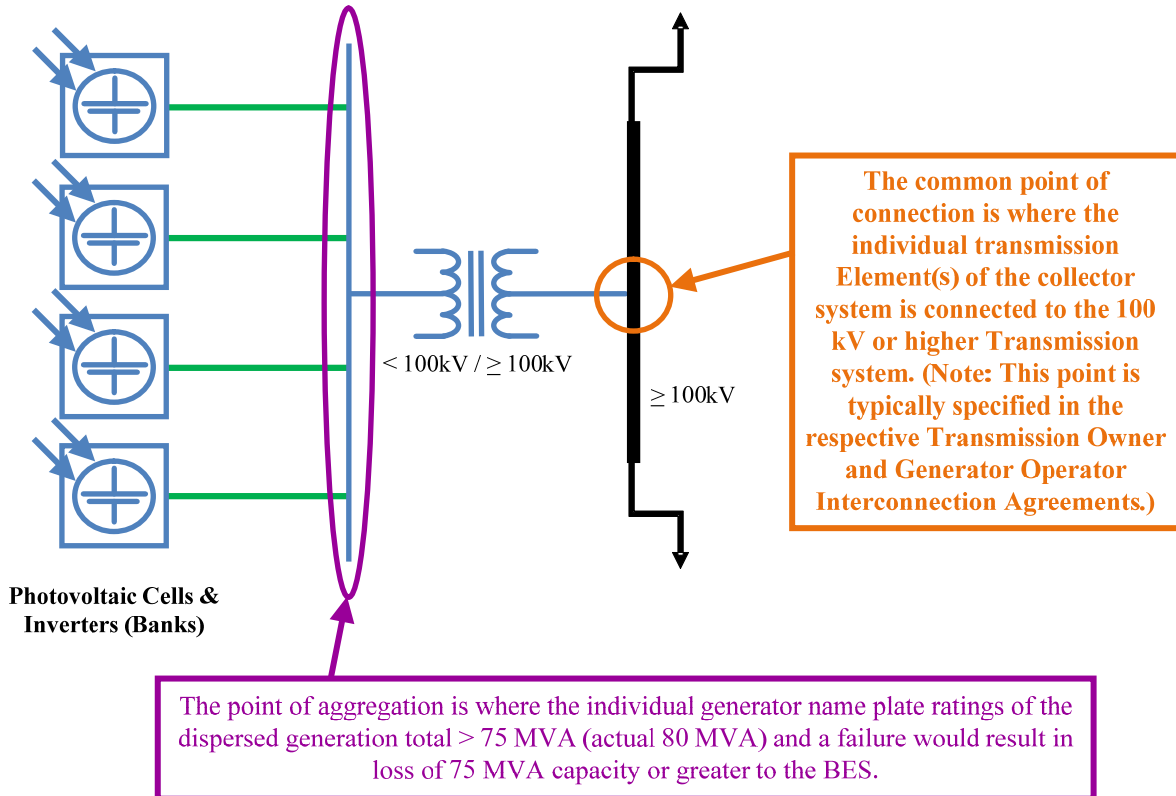

Figure I4-3: Dispersed Generation Site (Single Voltage Transformation) – Solar Array

Figure I4-4 depicts a dispersed generation site and substation design with multiple levels of voltage transformation.

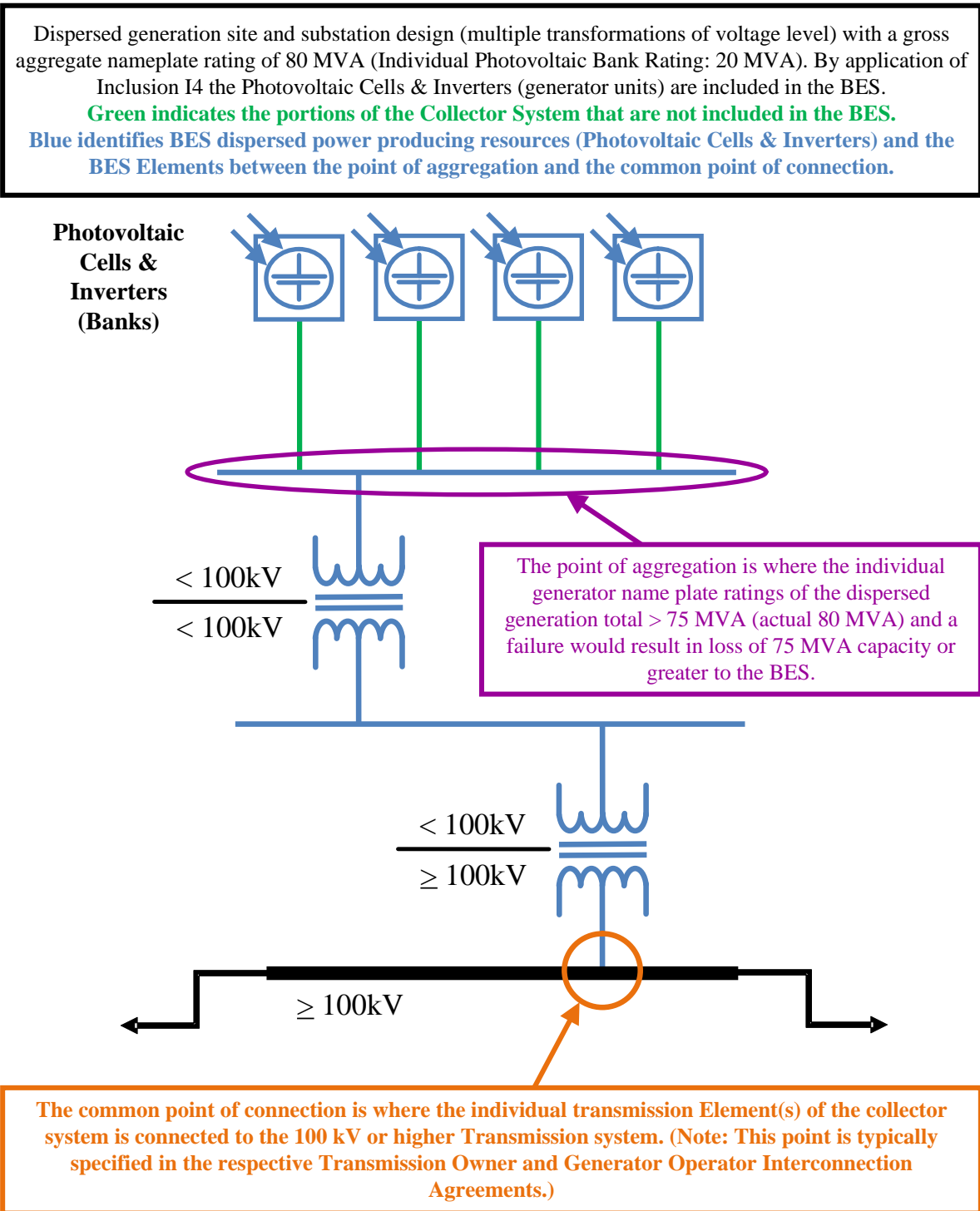

Figure I4-4: Dispersed Generation Site (Multiple Voltage Transformations) – Solar Array

11.4 BES Inclusion I5

I5. Static or dynamic devices (excluding generators) dedicated to supplying or absorbing Reactive Power that are connected at 100 kV or higher, or through a dedicated transformer with a high-side voltage of 100 kV or higher, or through a transformer that is designated in Inclusion I1.

Inclusion I5 identifies static or dynamic devices (identified as ‘Reactive Resources’ throughout the document to simplify the diagrams) connected via any of the methods identified by the qualifiers regardless of the amount of Reactive Power output/input. It is important to note Inclusion I5 identifies only those static or dynamic “devices” to be included by meeting the qualifying connection criteria, and does not include any of the associating qualifiers (i.e., associated dedicated transformers). In the following examples, several reactive resources (electrically depicted as capacitors) are identified with various connection methods.

Note: Figure I5-1 depicts the application of Inclusion I5 and is intended to assist the user during the hierarchical application of the BES definition.

Figure I5-1 depicts several different methods of connecting reactive resources typically utilized in the electric utility industry

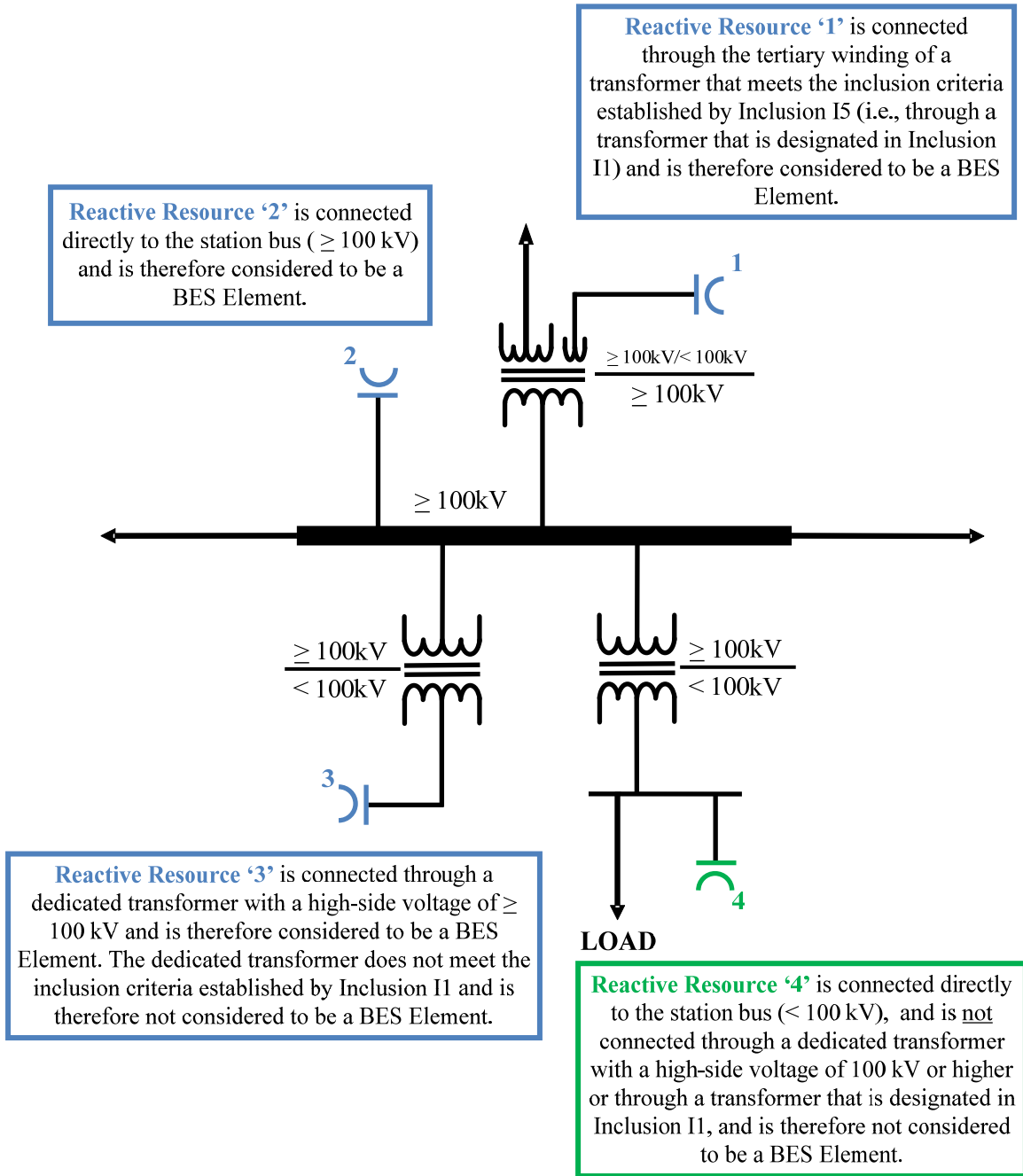

Figure I5-1: Reactive Resources (BES & non-BES)

III. Exclusions

Each exclusion, with the exception of Exclusion E4, is shown below with both text and diagrams explaining how to apply the BES definition for the specific configuration shown. These examples are not to be considered all-inclusive, and simply reflect the professional opinion of the DBES SDT and are provided in good faith for illustrative purposes only. This document is not an official position of NERC and will not be binding on enforcement decisions of the NERC Compliance Monitoring and Enforcement Program.

The section on Exclusion E4 does not include diagrams, as there are no application configuration issues associated with it.

Diagrams only show application of the definition to the specific Element in question, as previously explained.

Key to diagram color coding:

- **Blue** indicates that an Element is included in the BES.
- **Green** indicates that an Element is not included in the BES.
- **Orange** indicates 'points of connection'
- **Black** indicates Elements that are not evaluated for the specific exclusion depicted in the individual diagrams being shown

III.1 BES Exclusion E1

E1. Radial systems: A group of contiguous transmission Elements that emanates from a single point of connection of 100 kV or higher and:

- a.) Only serves Load. Or,
- b.) Only includes generation resources, not identified in Inclusions I2, I3, or I4, with an aggregate capacity less than or equal to 75 MVA (gross nameplate rating). Or,
- c.) Where the radial system serves Load and includes generation resources, not identified in Inclusions I2, I3, or I4, with an aggregate capacity of non-retail generation less than or equal to 75 MVA (gross nameplate rating).

Note 1 - A normally open switching device between radial systems, as depicted on prints or one-line diagrams for example, does not affect this exclusion.

Note 2 – The presence of a contiguous loop, operated at a voltage level of 50 kV or less, between configurations being considered as radial systems, does not affect this exclusion.

Single point of connection

The “single point of connection of 100 kV or higher” is where the radial system will begin if it meets the criteria of Exclusion E1, including parts a, b, or c. For example, the start of the radial system may be a hard tap of the Transmission line, or could be the tap point within a ring or breaker and a half bus configuration.

The connection to the radial system must be from only one point at 100 kV or higher. Any group of contiguous transmission Elements that have multiple connections at 100 kV or higher do not qualify for Exclusion E1.

Normally open switching devices between radial systems, will not disqualify a radial system from this exclusion.

FERC Order No. 773 directed implementation of the revised BES definition to take into account the impact of sub-100 kV looped Facilities regardless of voltage level altering previous guidance on the evaluation of radial systems. This meant that if there was a connection at the sub-100 kV level between two systems that would previously have been considered as radial, said systems could not be evaluated for possible radial system exclusion. However, the drafting team developed a technical justification establishing 50 kV as a threshold value for sub-100 kV looped facilities. If the sub-100 kV loop is 50 kV or less, it was shown that it would not have an impact on the BES and thus an entity could still apply Exclusion E1 to the configuration. If the loop in question was greater than 50 kV, then an entity could not consider the systems as radial and would need to evaluate them under the criteria of Exclusion E3 if seeking to exclude the Facilities from the BES.

The evaluation of sub-100 kV loops associated with the evaluation of Elements under the E1 exclusion is used as a “qualifier” for the potential exclusion of the Elements that operate at or above 100 kV.

- Failure to meet the “bright-line” criteria established by Exclusion E1 does not result in the inclusion of the sub-100 kV loops in the BES.
- Order No. 773, paragraph 155 states:
- *“Thus, the Commission, while disagreeing with NERC’s interpretation, does not propose to include the below 100 kV elements in figure 3 in the bulk electric system, unless determined otherwise in the exception process.”*
- Order No. 773-A, paragraph 36 states:
“Moreover, as noted in the Final Rule, the sub-100 kV elements comprising radial systems and local networks will not be included in the bulk electric system, unless determined otherwise in the exception process.”

Evaluation of single points of connection within radial systems under consideration

If the radial system being evaluated for exclusion emanates from a single point of connection of 100 kV or higher but does not meet the criteria established in Exclusion E1, including parts a, b, or c, then the radial system does not qualify for exclusion from the BES as a radial system described in Exclusion E1 and its parts. However, further evaluation of the underlying Elements within the original radial system may be appropriate. Underlying radial systems, which emanate from a single point of connection of 100 kV or higher, may qualify for exclusion as radial systems of contiguous transmission Elements within the original area of consideration if the criterion established in Exclusion E1, including parts a, b, or c, is met for these Facilities. Such evaluations are not shown in the figures in this section which concentrate on the bigger picture, but are detailed in the summary diagrams in Section IV where the hierarchical application of the definition is described and shown. (See Figures S1-10 and S1-10a of this document to view examples of the hierarchical application of the BES definition with respect to Exclusion E1.)

"transmission Element"

The word transmission is not capitalized and is used as a qualifier to the word Element and is meant to differentiate between the types of Elements that are identified in the NERC Glossary of Terms Used in NERC Reliability Standards definition of Element.

Element (NERC Glossary of Terms):

“Any electrical device with terminals that may be connected to other electrical devices such as a generator, transformer, circuit breaker, bus section, or transmission line. An element may be comprised of one or more components.”

The use of the words: “a group of contiguous transmission Elements,” means Elements at 100 kV or higher that are connected in a contiguous manner. This group of contiguous transmission Elements serves the radial system but does not include the Elements that are operated below 100 kV.

Non-retail Generation

Non-retail generation is any generation that is not behind a retail customer’s meter. The radial system is limited to less than 75 MVA of non-retail generation.

Retail generation is behind-the-meter generation with all or some of the generation serving Load. The NERC Glossary of Terms Used in NERC Reliability Standards defines Load as “an end-use device or customer that receives power from the electric system”.

For retail generation meeting the criteria established by Exclusion E2, the retail generation not consumed on site can flow to the BES provided the net capacity to the BES does not exceed 75 MVA.

The MVA nameplate rating of retail generation can affect the ability of an entity to utilize Exclusion E1 (See E1.b).

Reactive Resources

Exclusion E1 provides for the exclusion of ‘transmission Elements’ from radial systems that meet the specific criteria identified in the exclusion language. This does not allow for the exclusion of Reactive Power resources captured by Inclusion I5. Exclusion E1 only speaks to the transmission component of the radial system.

Generation Limits

There are two conditions under which generation resources can prevent a radial system from qualifying for Exclusion E1:

1. Any generation within the radial system in question is identified in Inclusion I2, I3, or I4; or

2. The aggregate nameplate capacity of the non-retail generation capacity within the radial system in question exceeds 75 MVA.

If either of these conditions applies, the radial system does not qualify for Exclusion E1.

Exclusion E1 allows for the exclusion of contiguous transmission Elements (i.e., transformers, circuit breakers, bus sections, Transmission lines, etc.) emanating from a single point of connection at a voltage of 100 kV or higher.

Note: Figures E1-1 through E1-20 are depictions of the application of Exclusion E1, and are intended to assist the user during the hierarchical application of the BES definition.

E1.a—Serves Load Only

Figure E1-1 depicts a radial system that contains only Load. There is no limit to the amount of Load within the radial system.

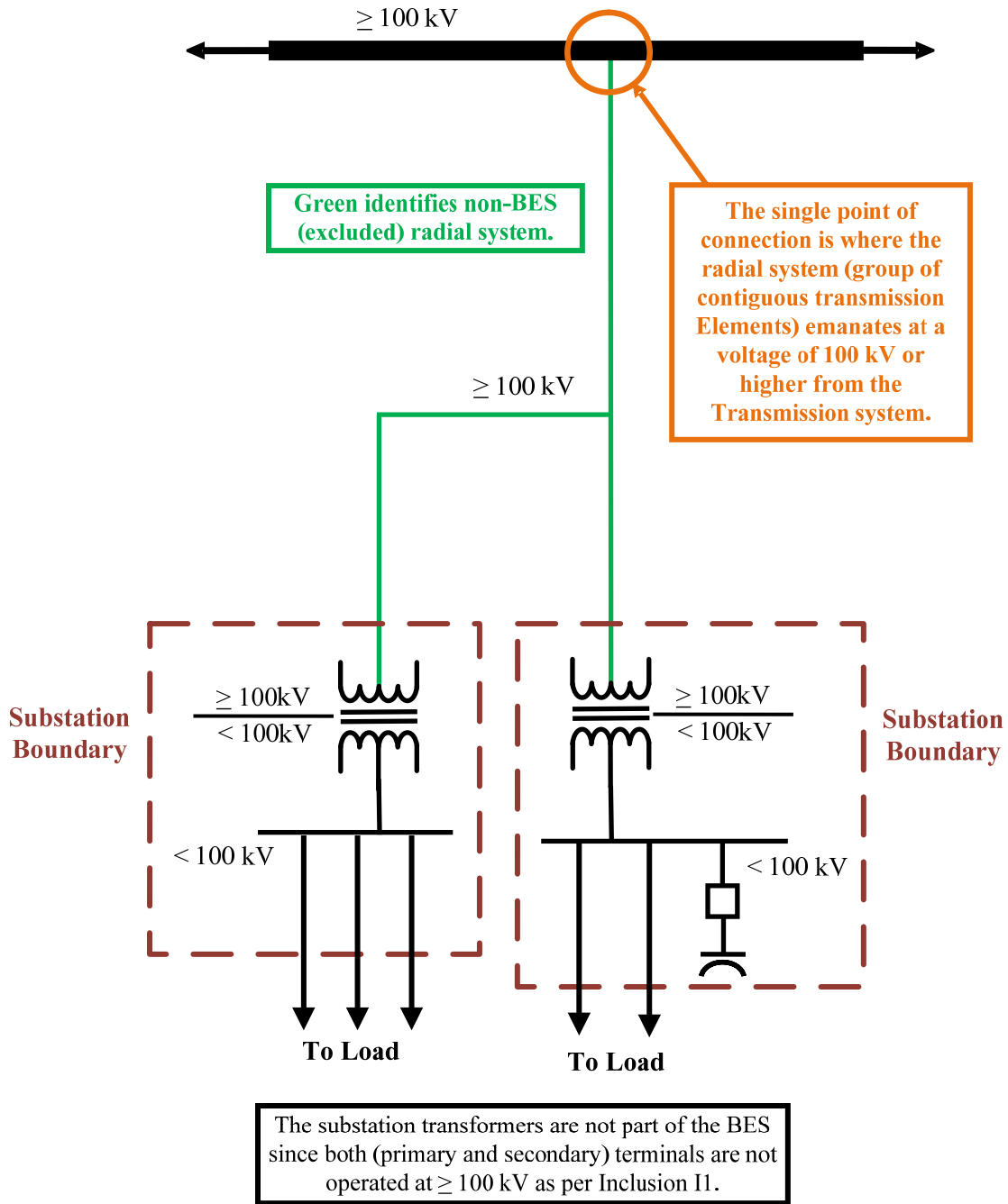

Figure E1-1: Radial System: Serving Only Load

Figure E1-2 depicts a configuration that contains two separate radial systems due to the underlying loop operating at a voltage of ≤ 50 kV.

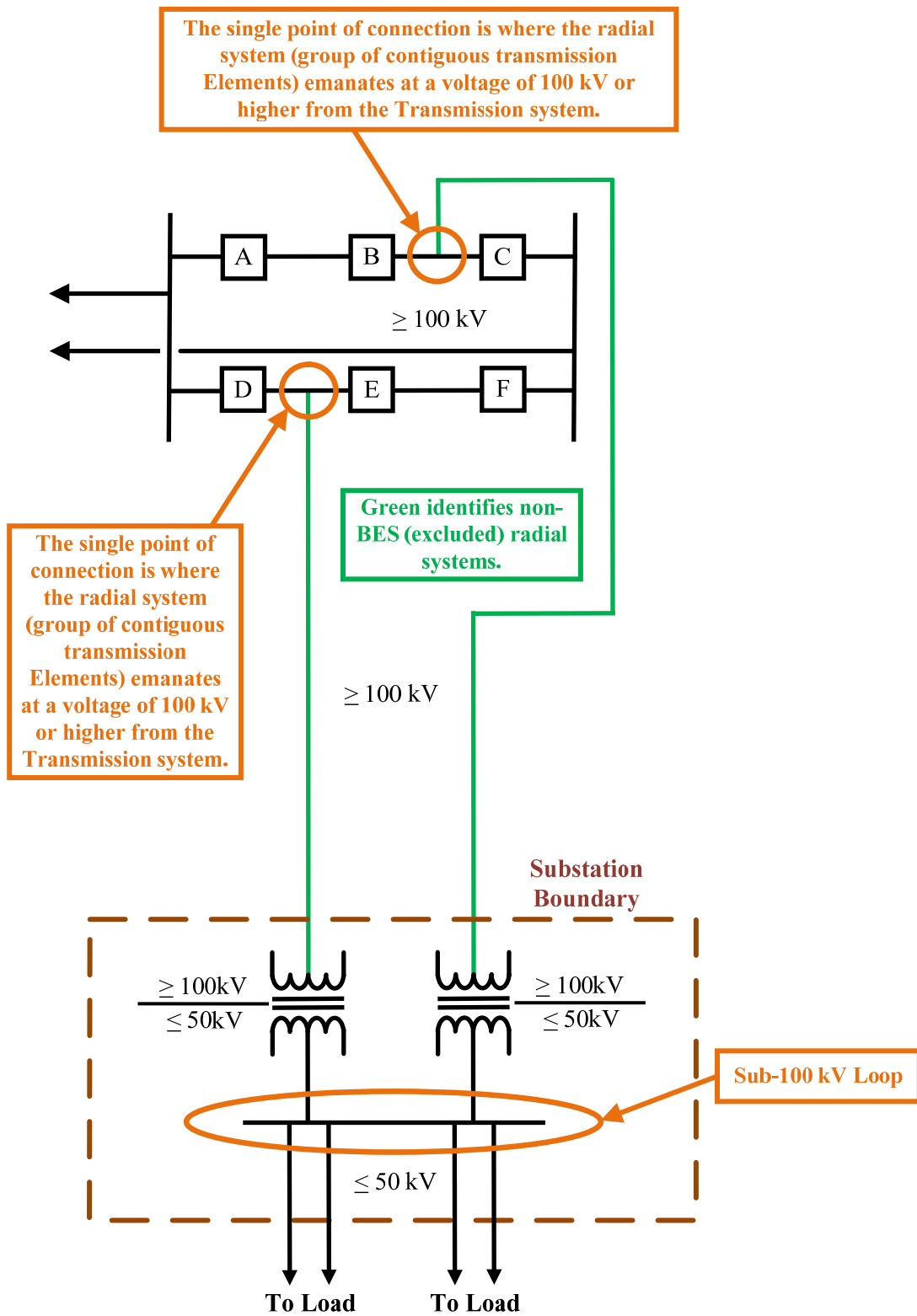

Figure E1-2: Multiple Radial Systems (Underlying Loop Facilities ≤ 50 kV)

Figure E1-3 depicts a configuration that contains a sub-100 kV loop (greater than 50 kV), which cannot be evaluated under the criteria established in Exclusion E1 and can only be evaluated under the criteria established in Exclusion E3 (See diagram E3-4).

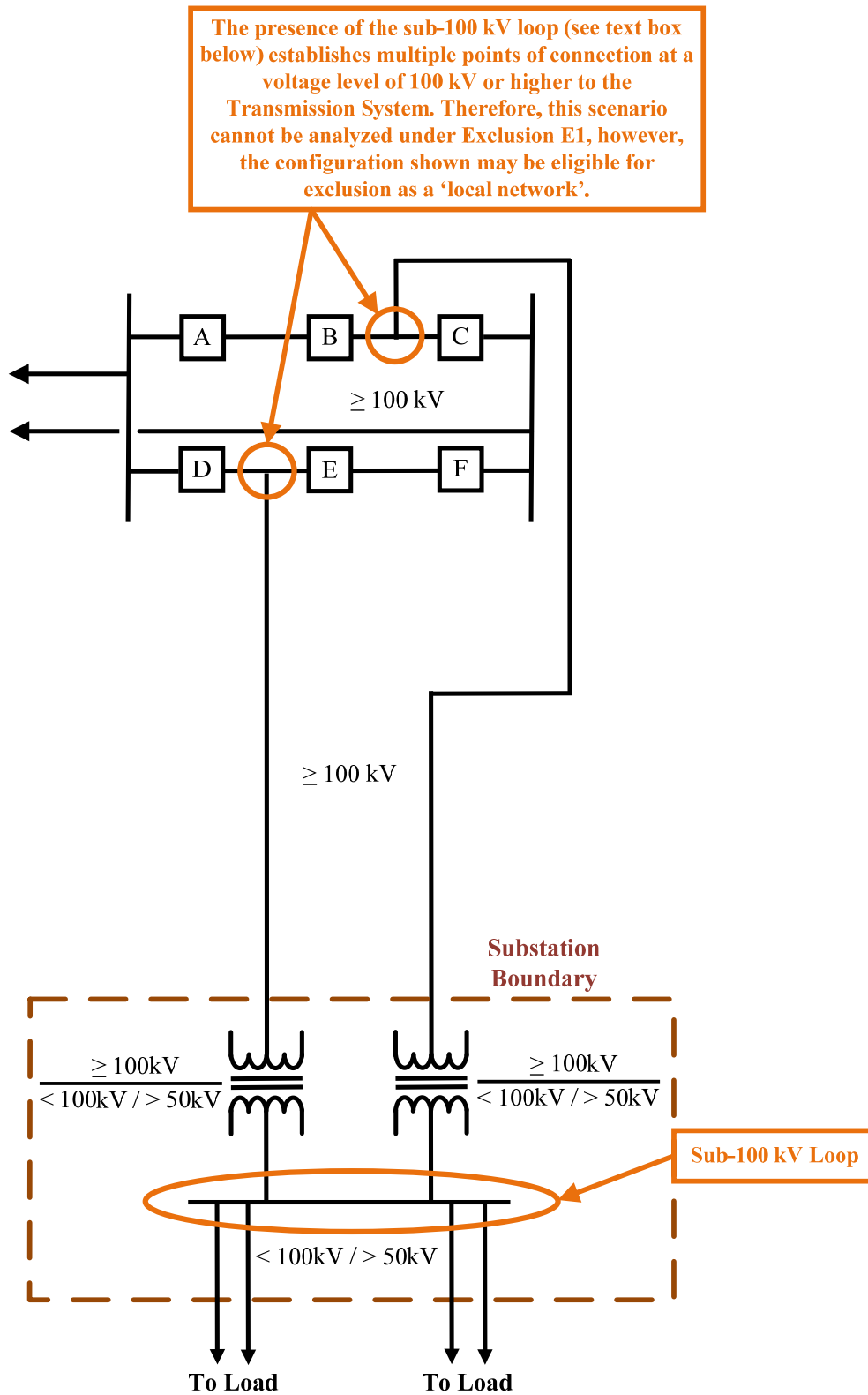

Figure E1-3: Impact of Sub-100 kV Looped Facilities

E1.b—Generation Only

Figure E1-4 depicts a radial system with a single generation resource (non-retail) and no Load.

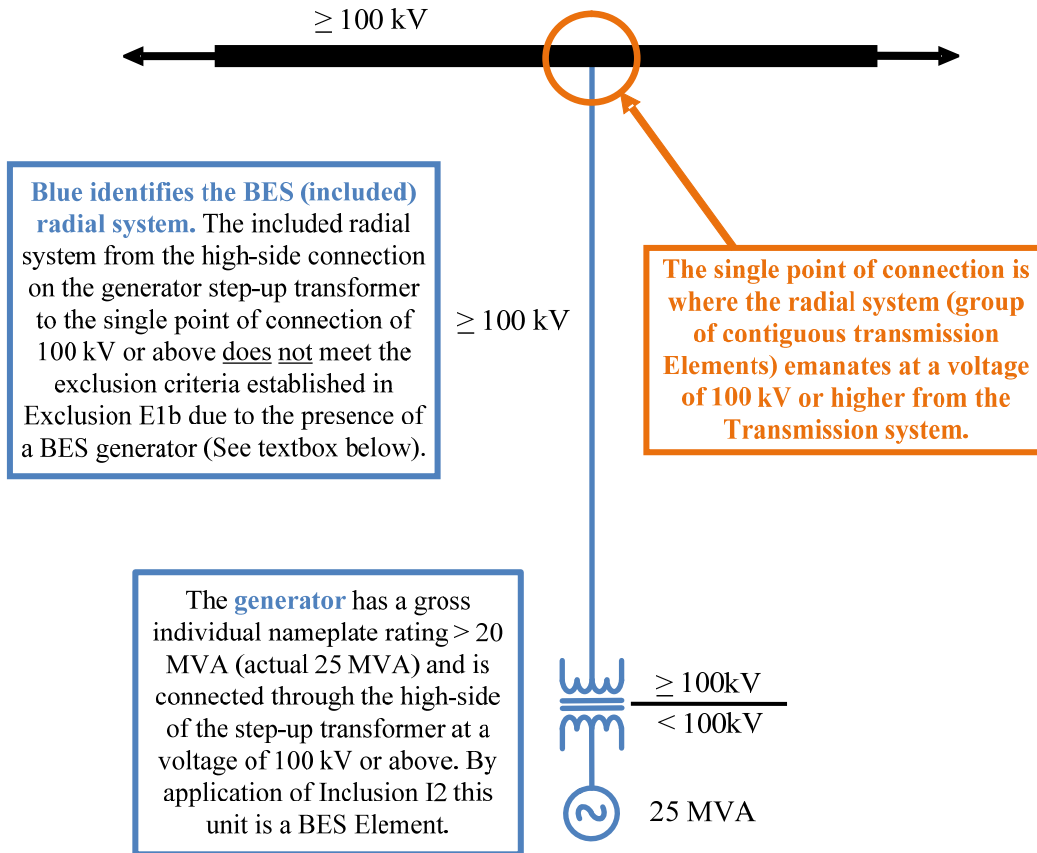

Figure E1-4: Radial System: Single BES Generation Resource

Figure E1-5 depicts a radial system with a single generation resource (non-retail) and no Load.

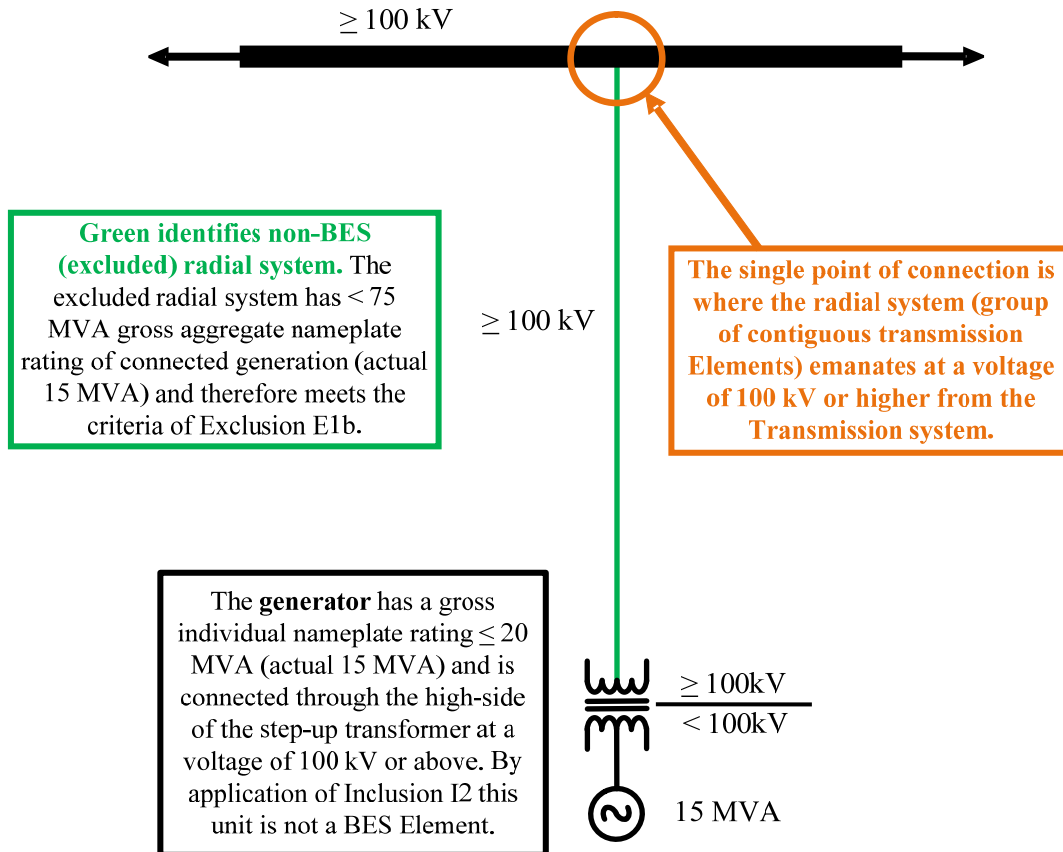

Figure E1-5: Radial System: Single non-BES Generation Resource

Figure E1-6 depicts a radial system with a Blackstart Resource, and no Load. The Radial System does not meet the exclusion criteria of E1.b due to the presence of the Blackstart Resource.

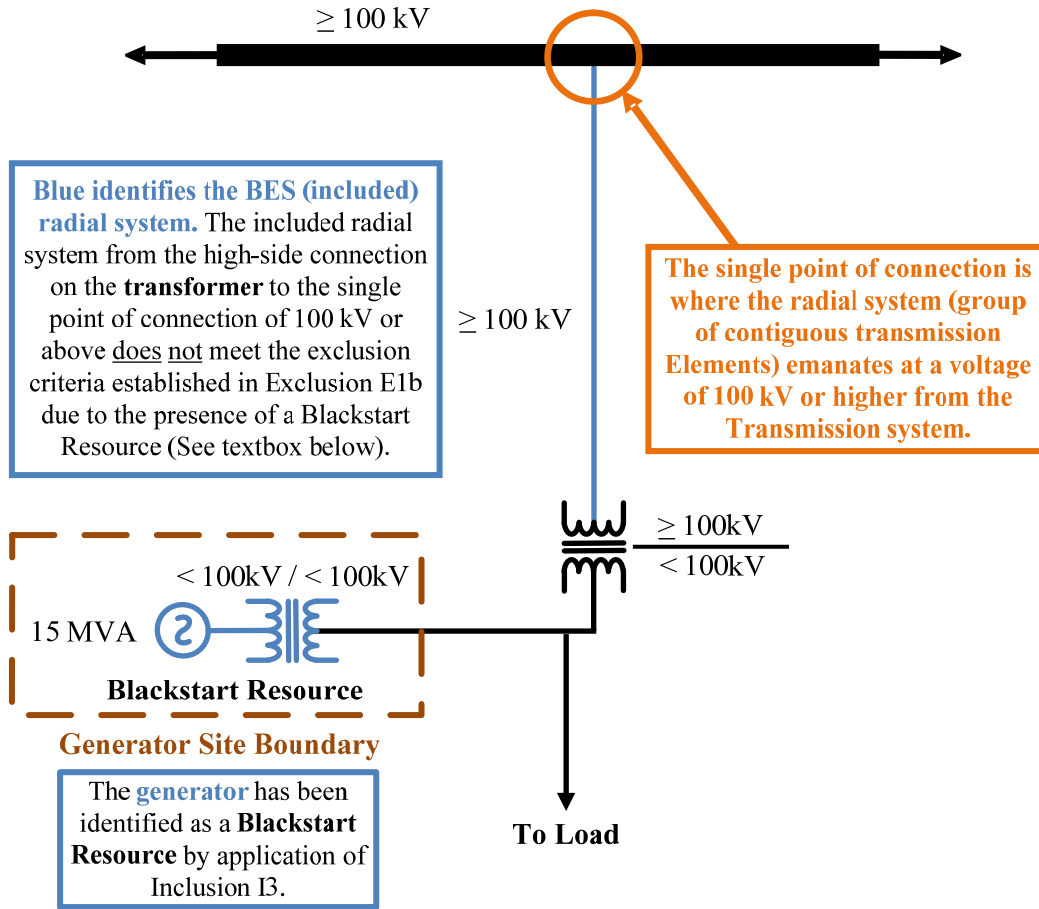

Figure E1-6: Radial System: Blackstart Resource

Figure E1-7 depicts a radial system with multiple generation resources (non-retail) and no Load. Since the area under consideration does not meet the criteria established by Exclusion E1.b, further evaluation of the underlying Elements may be appropriate. Each underlying Element must meet the criteria established by Exclusion E1, including parts a, b, or c, to qualify for exclusion from the BES. Such evaluations are not shown in Figure E1-7, which concentrates on the bigger picture, but are detailed in the summary diagrams in Section IV where the hierarchical application of the definition is described and shown.

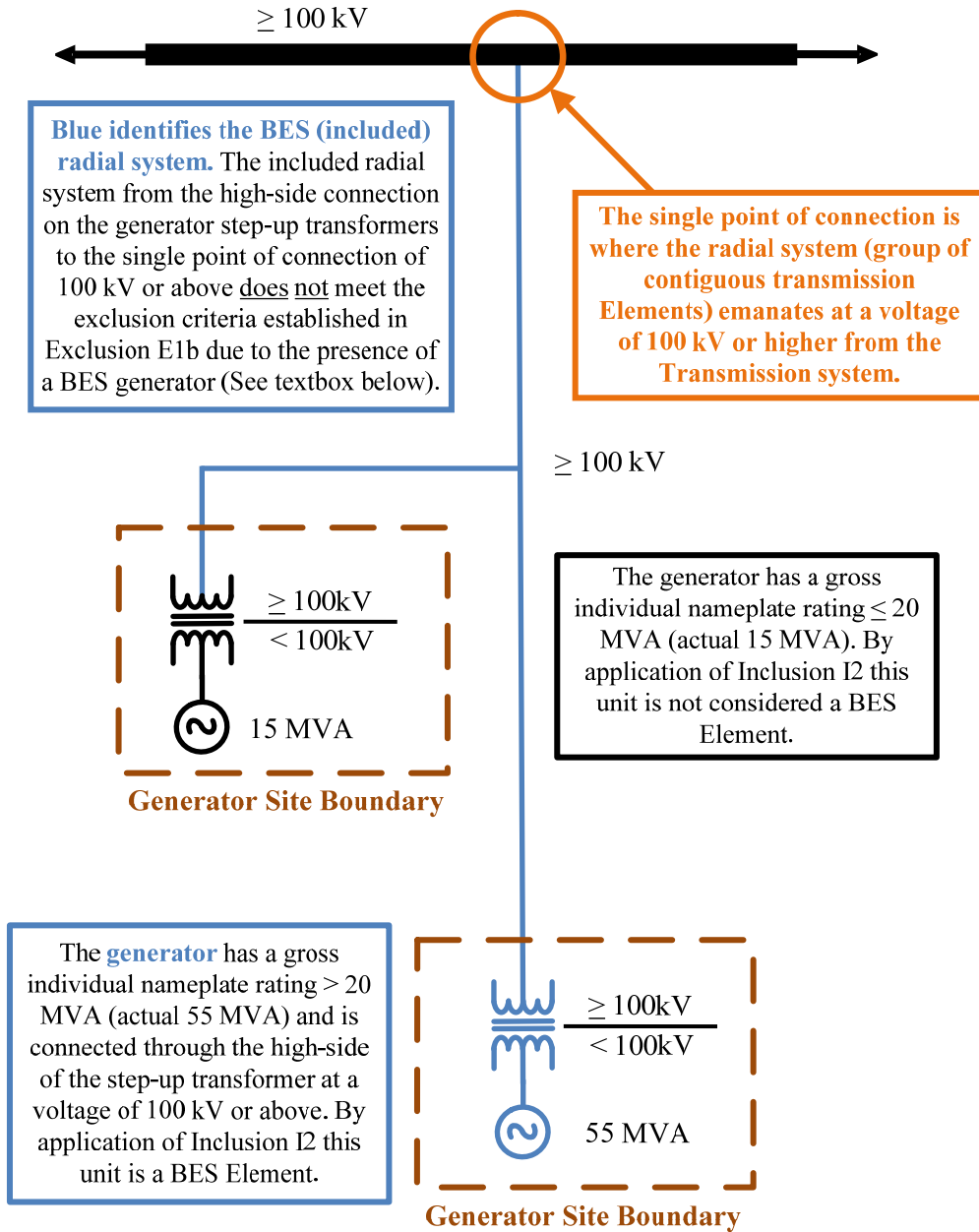

Figure E1-7: Radial System: Multiple (BES & non-BES) Generation Resources (Non-Retail)

Figure E1-8 depicts a radial system with multiple generation resources and no Load. The aggregate gross nameplate values of the generation resources exceed the 75 MVA threshold established by Exclusion E1.b. Since the area under consideration does not meet the criteria established by Exclusion E1.b, further evaluation of the underlying Elements may be appropriate. Each underlying Element must meet the criteria established by Exclusion E1, including parts a, b, or c, to qualify for exclusion from the BES. Such evaluations are not shown in Figure E1-8, which concentrates on the bigger picture, but are detailed in the summary diagrams in Section IV where the hierarchical application of the definition is described and shown.

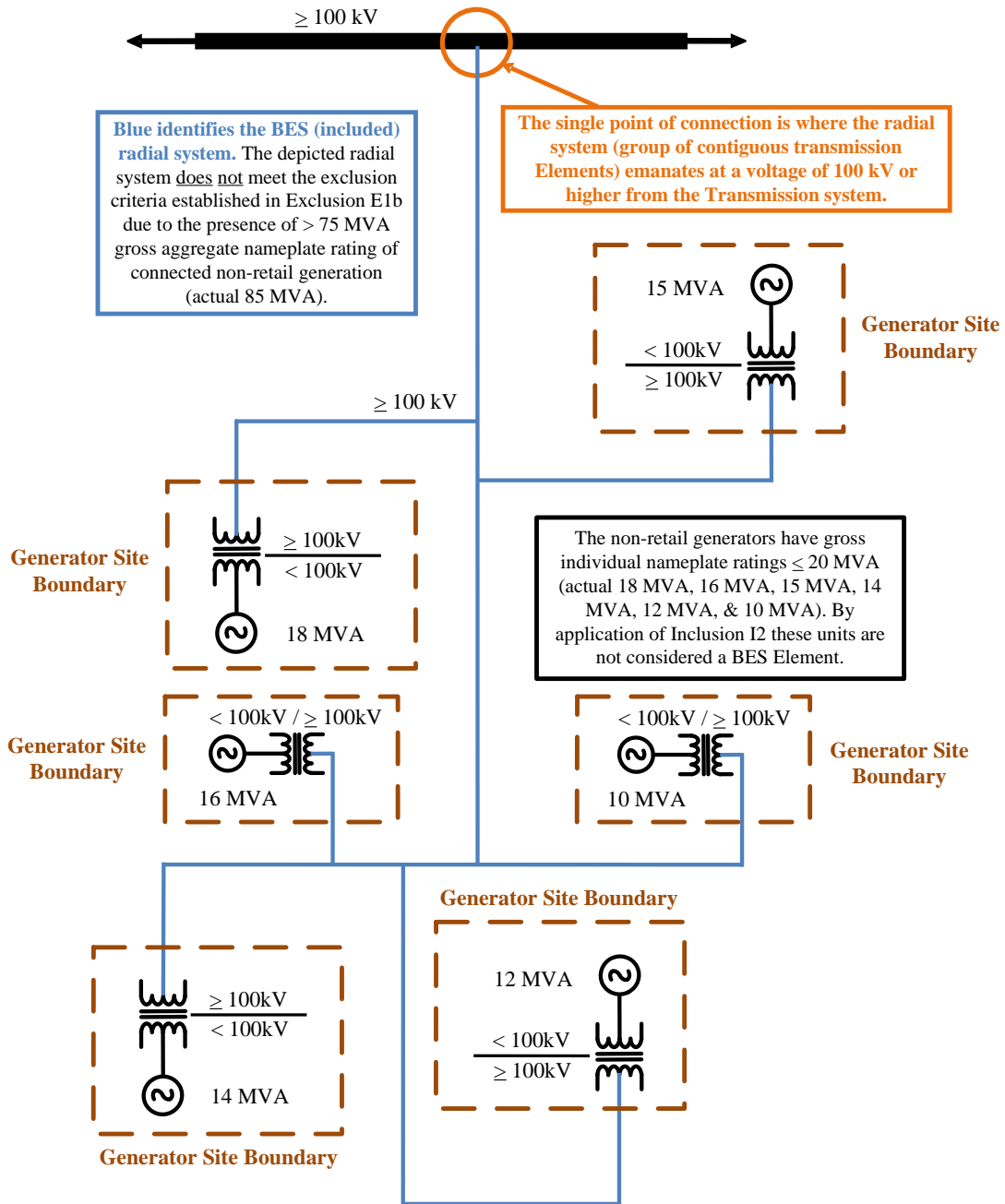

Figure E1-8: Radial System: Multiple (non-BES) Generation Resources (Non-Retail)

Figure E1-9 depicts a radial system with multiple generation resources and no Load.

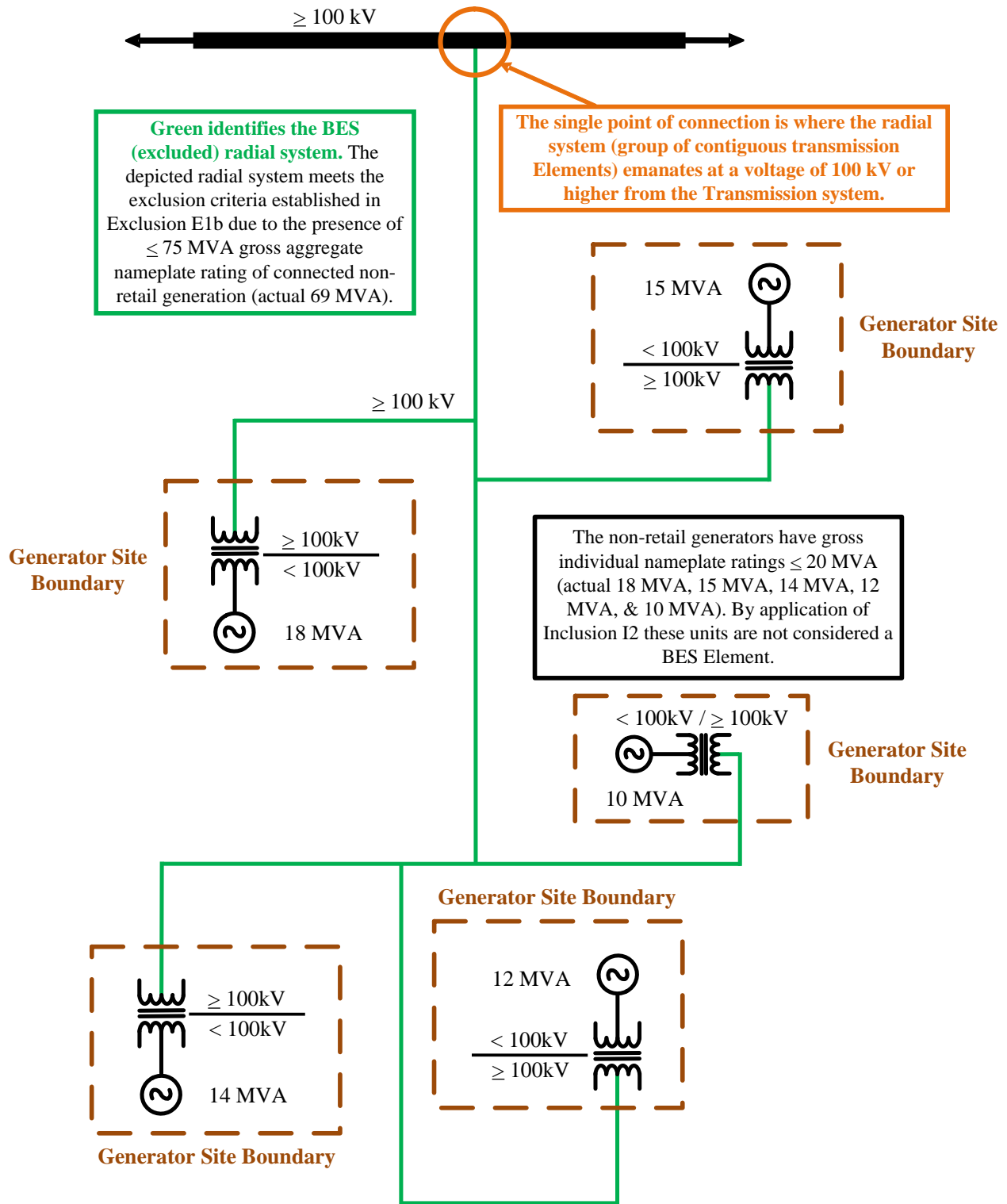

Figure E1-9: Radial System: Multiple (non-BES) Generation Resources (Non-Retail)

Figure E1-10 depicts a radial system with multiple generation resources (retail and non-retail) and no Load. The customer owned generation (retail) and associated customer owned equipment are excluded from the BES by application of Exclusion E2 and is not considered a component of the aggregated total generation within the radial system.

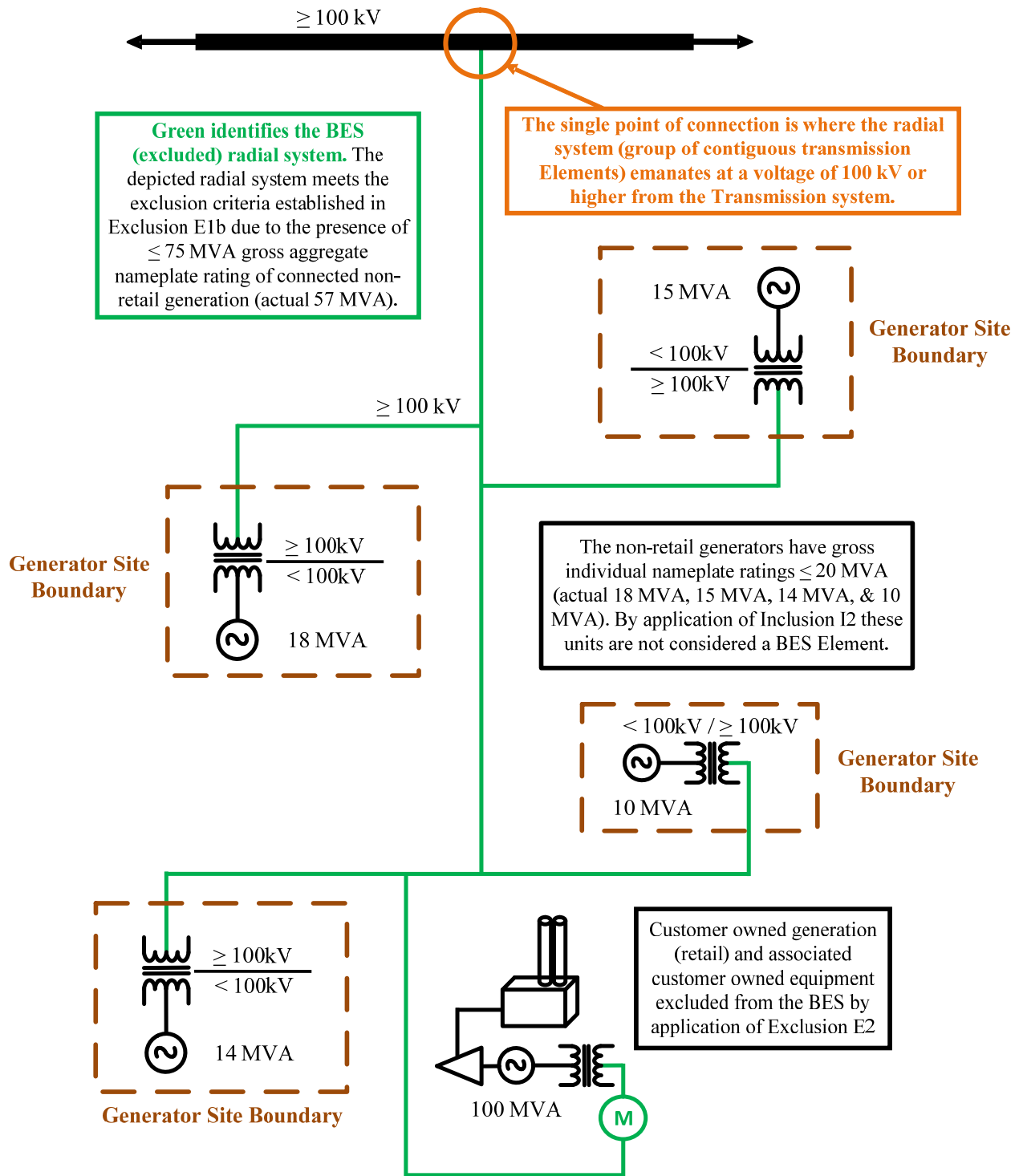

Figure E1-10: Radial System: Multiple (non-BES) Generation Resources (Retail & Non-Retail)

E1.c - Generation and Serves Load

Figure E1- 11 depicts a radial system with generation resources (non-retail) that also serves Load. Since the area under consideration does not meet the criteria established by Exclusion E1.c, further evaluation of the underlying Elements may be appropriate. Each underlying Element must meet the criteria established by Exclusion E1, including parts a, b, or c, to qualify for exclusion from the BES. Such evaluations are not shown in Figure E1-11, which concentrates on the bigger picture, but are detailed in the summary diagrams in Section IV where the hierarchical application of the definition is described and shown.

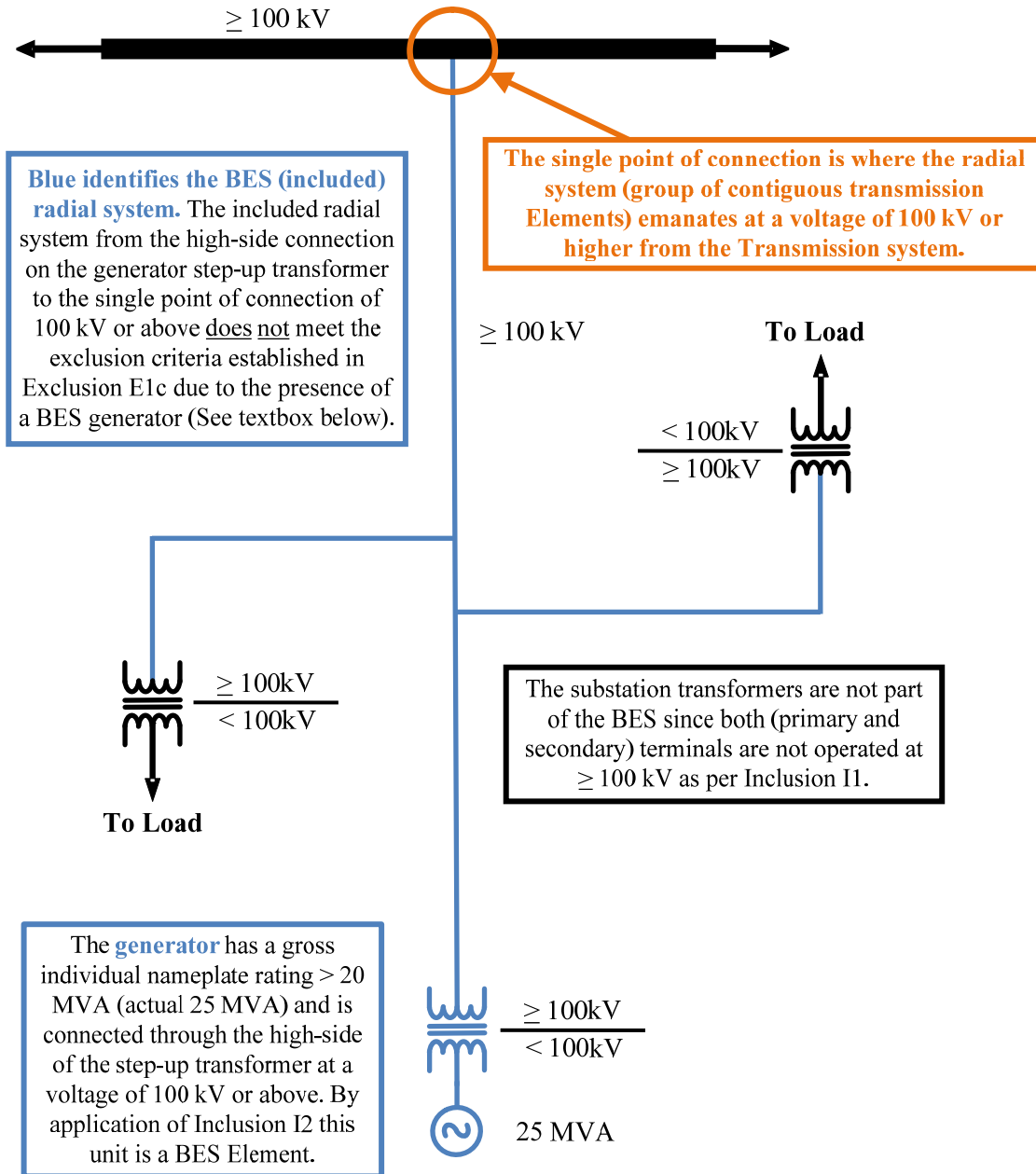

Figure E1-11: Radial System: Generation Resource (Non-Retail) & Serving Load

Figure E1- 12 depicts a radial system with generation resources (non-retail) that also serves Load.

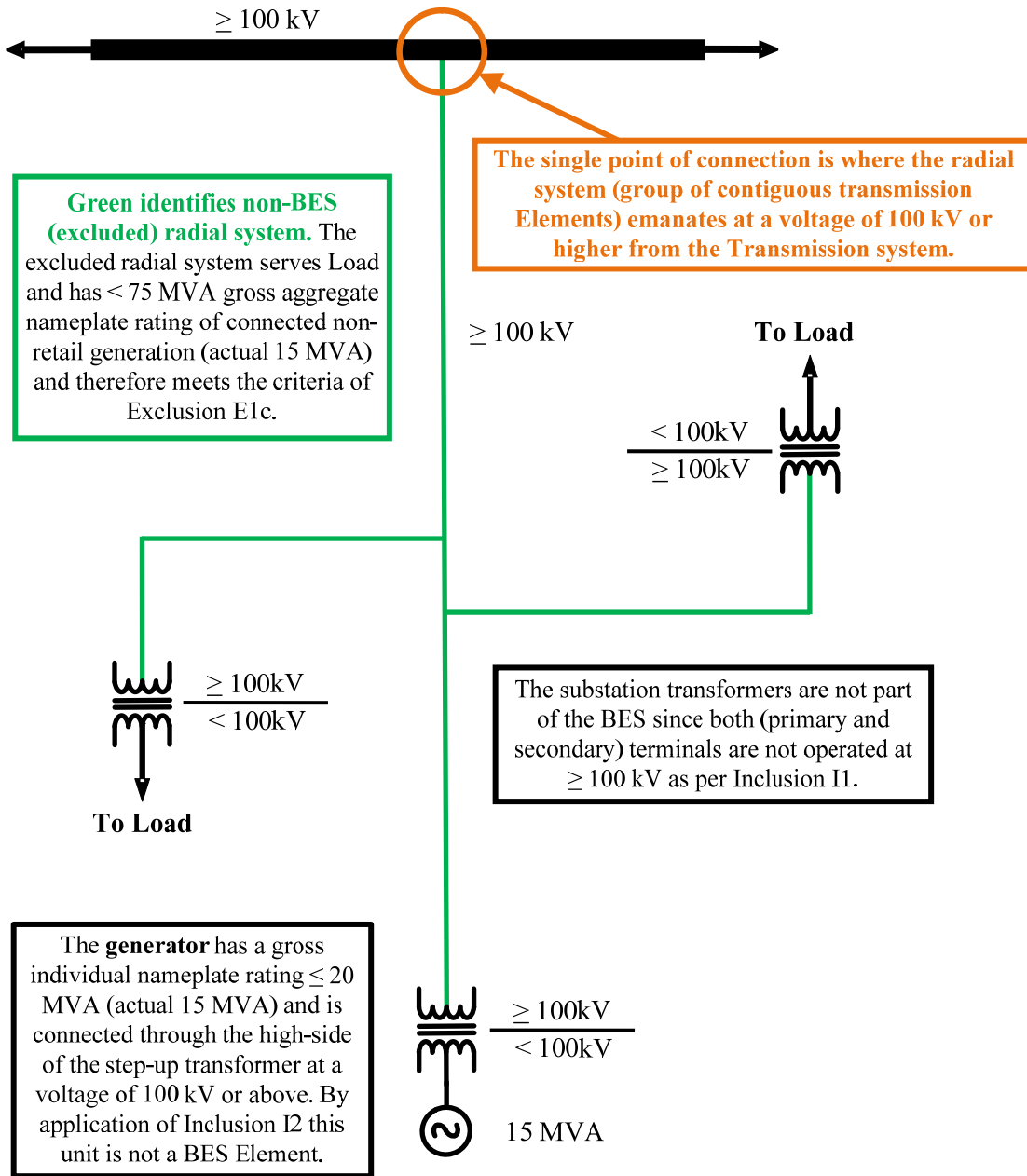

Figure E1-12: Radial System: Generation Resource (Non-Retail) & Serving Load

Figure E1- 13 depicts a radial system with generation resources (non-retail) that also serves Load. Since the area under consideration does not meet the criteria established by Exclusion E1.c, further evaluation of the underlying Elements may be appropriate. Each underlying Element must meet the criteria established by Exclusion E1, including parts a, b, or c, to qualify for exclusion from the BES. Such evaluations are not shown in Figure E1-13, which concentrates on the bigger picture, but are detailed in the summary diagrams in Section IV where the hierarchical application of the definition is described and shown.

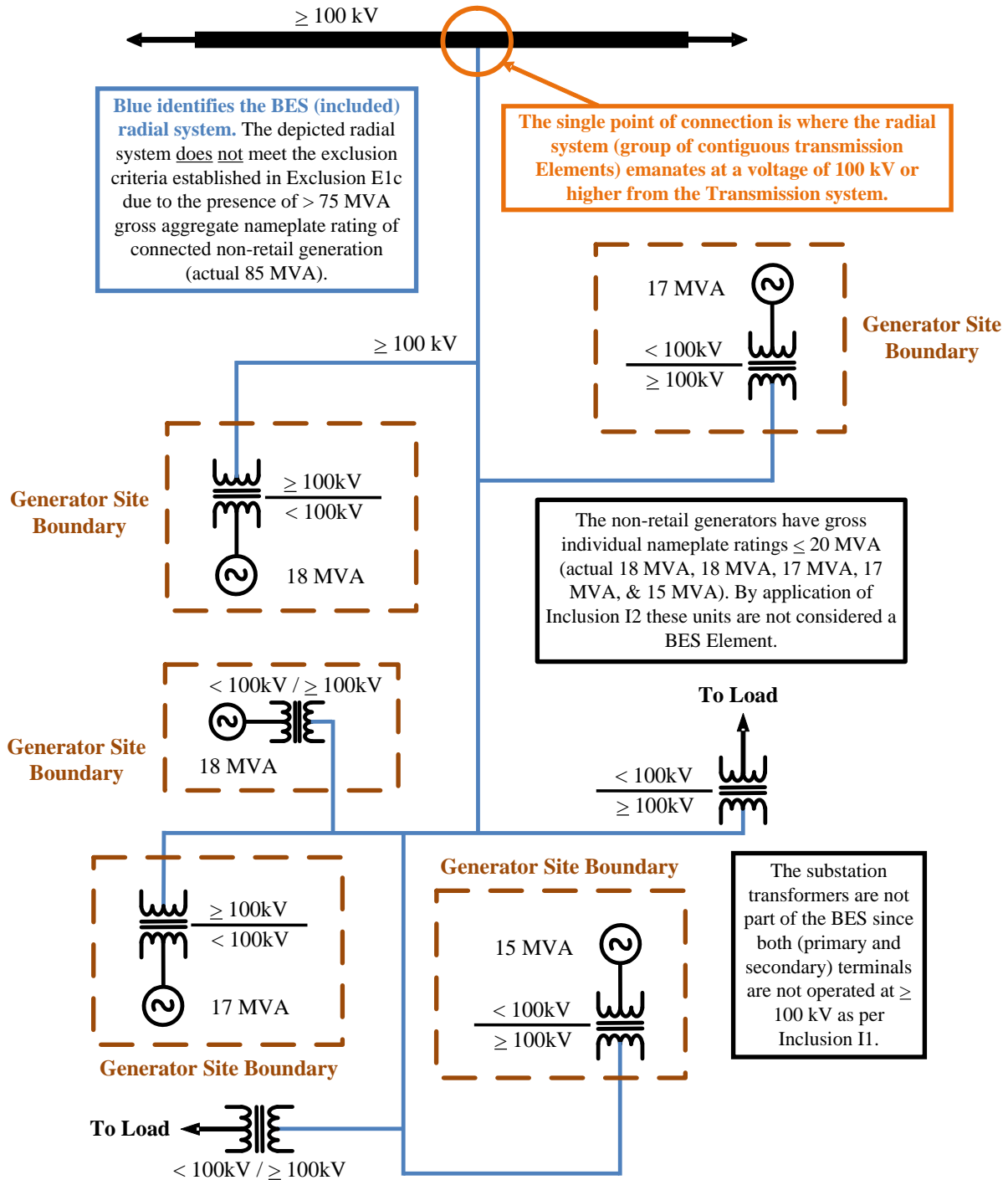

Figure E1-13: Radial System: Generation Resource (Non-Retail) & Serving Load

Figure E1- 14 depicts a radial system with generation resources (non-retail) that also serves Load.

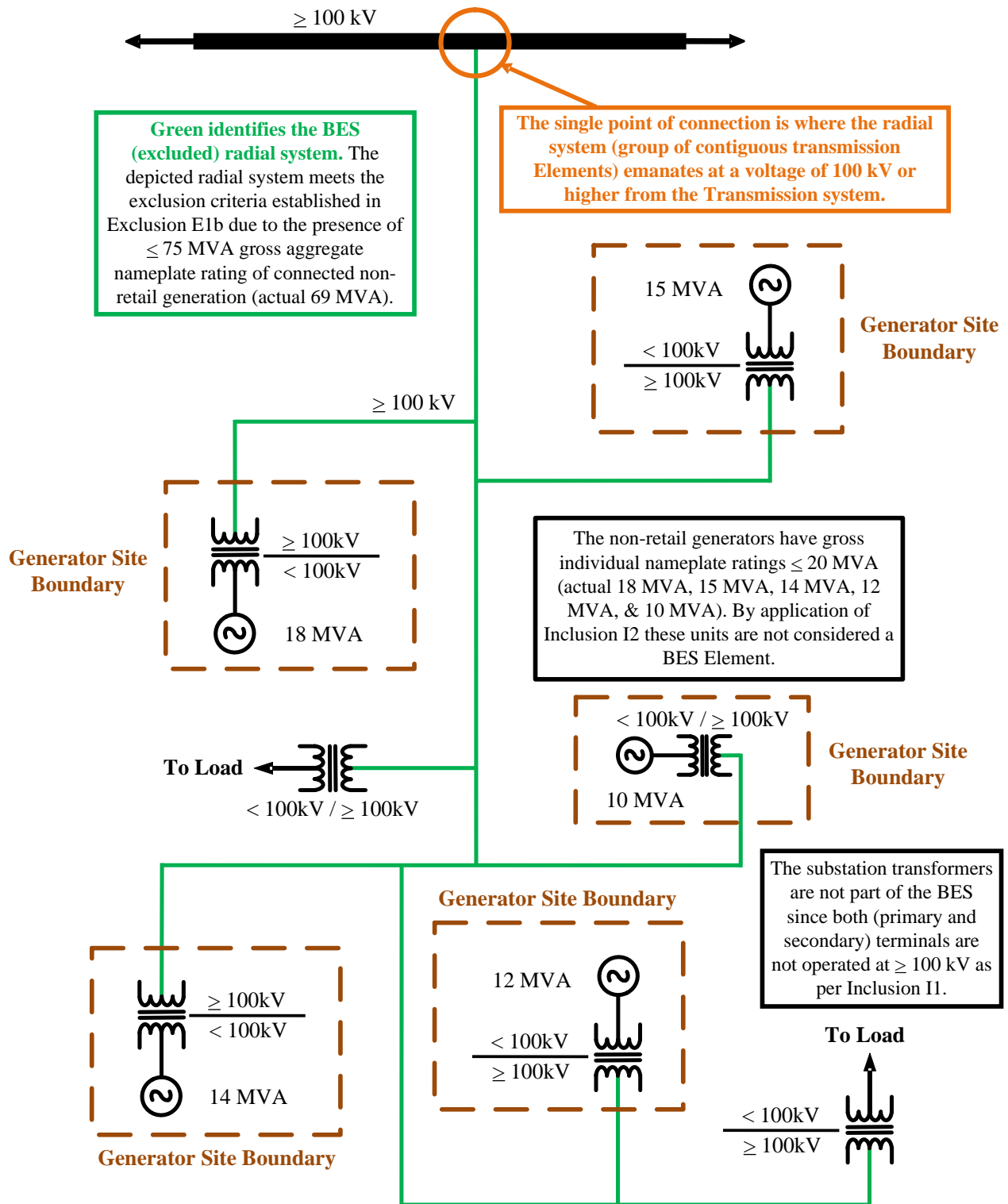

Figure E1-14: Radial System: Generation Resource (Non-Retail) & Serving Load

Figure E1- 15 depicts a radial system with generation resources (retail and non-retail) that also serves Load.

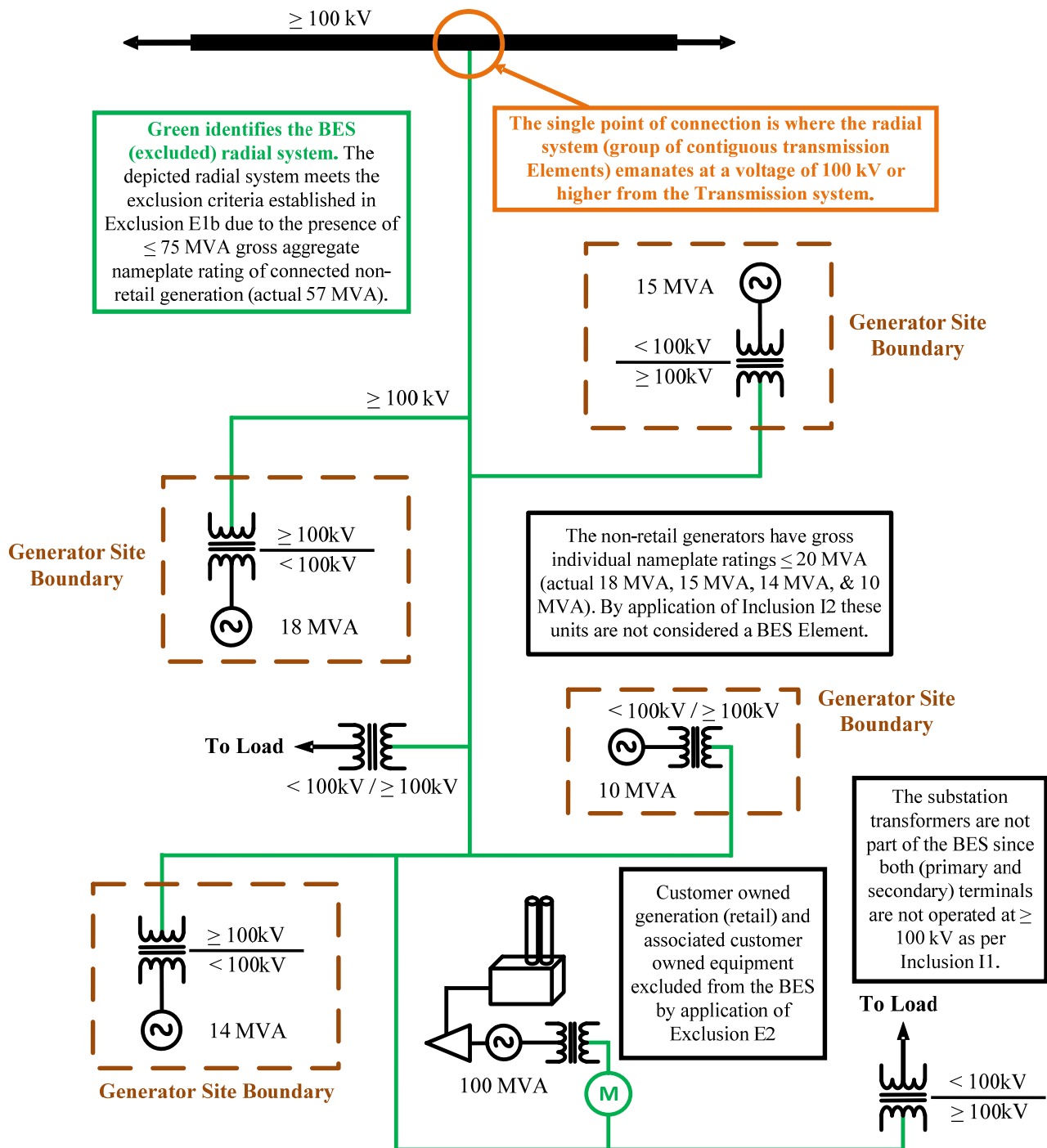

Figure E1-15: Radial System: Generation Resource (Retail & Non-Retail) & Serving Load

Normally open switching device

Radial systems should be assessed with all normally open (N.O.) devices in the open position. N.O. devices installed at any voltage level will not prevent the owner or operator from using this exclusion. The N.O. device(s) must be identified as such on prints and one-line diagrams that are used by the operating entity.

Figure E1-16 depicts multiple radial systems separated by a N.O. switching device operated at 100 kV or above.

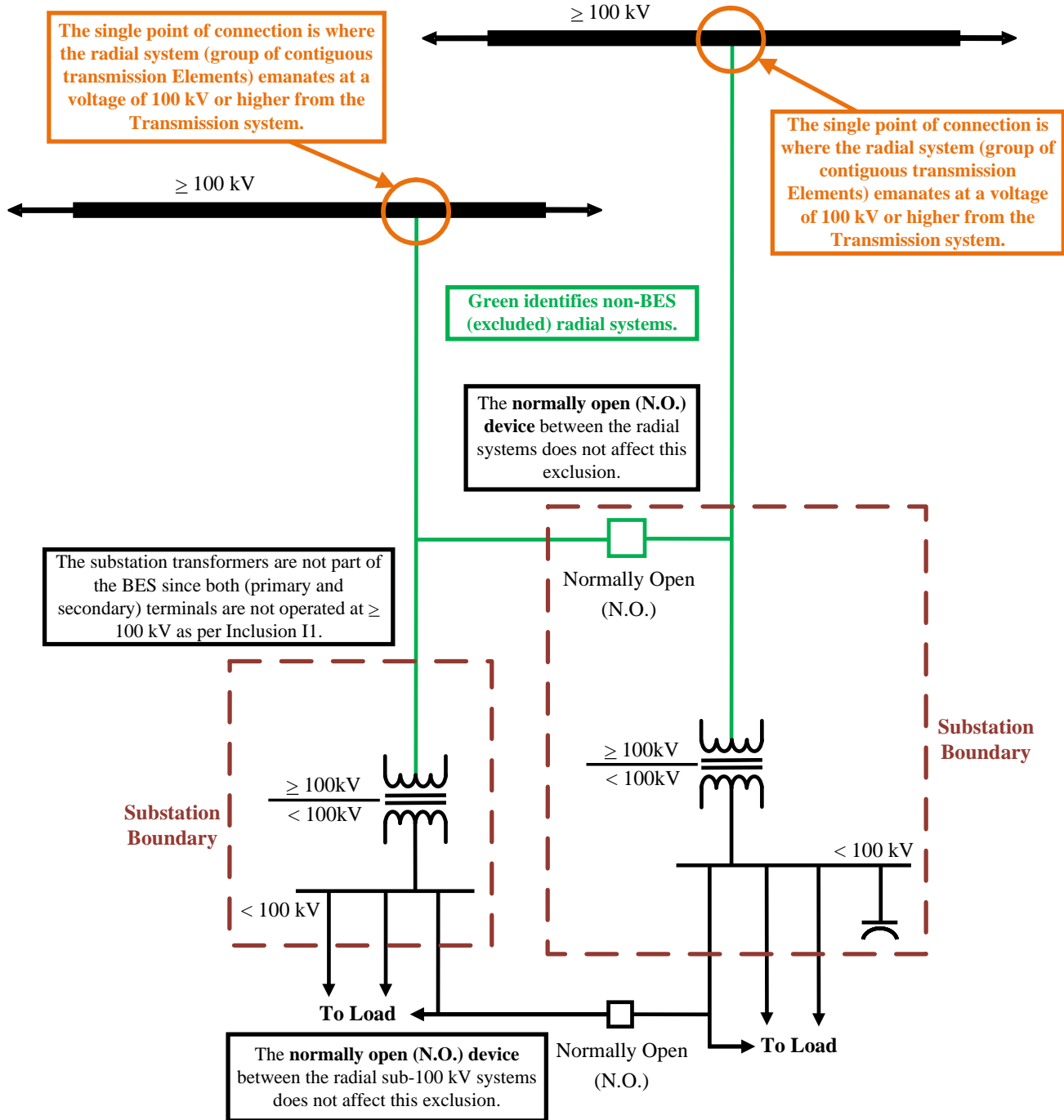

Figure E1-16: Radial System: Normally Open Switching Device between Load Serving Radial Systems

FERC Order No. 773 directed implementation of the revised BES definition to take into account the impact of sub-100 kV looped Facilities regardless of voltage level altering previous guidance on the evaluation of radial systems. This meant that if there was a connection at the sub-100 kV level between two systems that would previously have been considered as radial, said systems could not be evaluated for possible radial system exclusion. However, the drafting team developed a technical justification establishing 50 kV as a threshold value for sub-100 kV looped facilities. If the sub-100 kV loop is 50 kV or less, it was shown that it would not have an impact on the BES and thus an entity could still apply Exclusion E1 to the configuration. If the loop in question was greater than 50 kV, then an entity could not consider the systems as radial and would need to evaluate them under the criteria of Exclusion E3 if seeking to exclude the Facilities from the BES.

The evaluation of sub-100 kV loops associated with the evaluation of Elements under the E1 exclusion is used as a “qualifier” for the potential exclusion of the Elements that operate at or above 100 kV.

- Failure to meet the “bright-line” criteria established by Exclusion E1 does not result in the inclusion of the sub-100 kV loops in the BES.
- Order No. 773, paragraph 155 states:
“Thus, the Commission, while disagreeing with NERC’s interpretation, does not propose to include the below 100 kV elements in figure 3 in the bulk electric system, unless determined otherwise in the exception process.”
- Order No. 773-A, paragraph 36 states:
“Moreover, as noted in the Final Rule, the sub-100 kV elements comprising radial systems and local networks will not be included in the bulk electric system, unless determined otherwise in the exception process.”

Note: Figures E1-17 through E1-20 depict scenarios that require evaluation based on the criteria established in the BES definition as revised by the FERC Order and described above.

Figure E1-18 depicts a situation which cannot be evaluated under the criteria established in Exclusion E1 and can only be evaluated under the Exclusion E3 criteria since the underlying loop is ≥ 50 kV (see Figure E3-6).

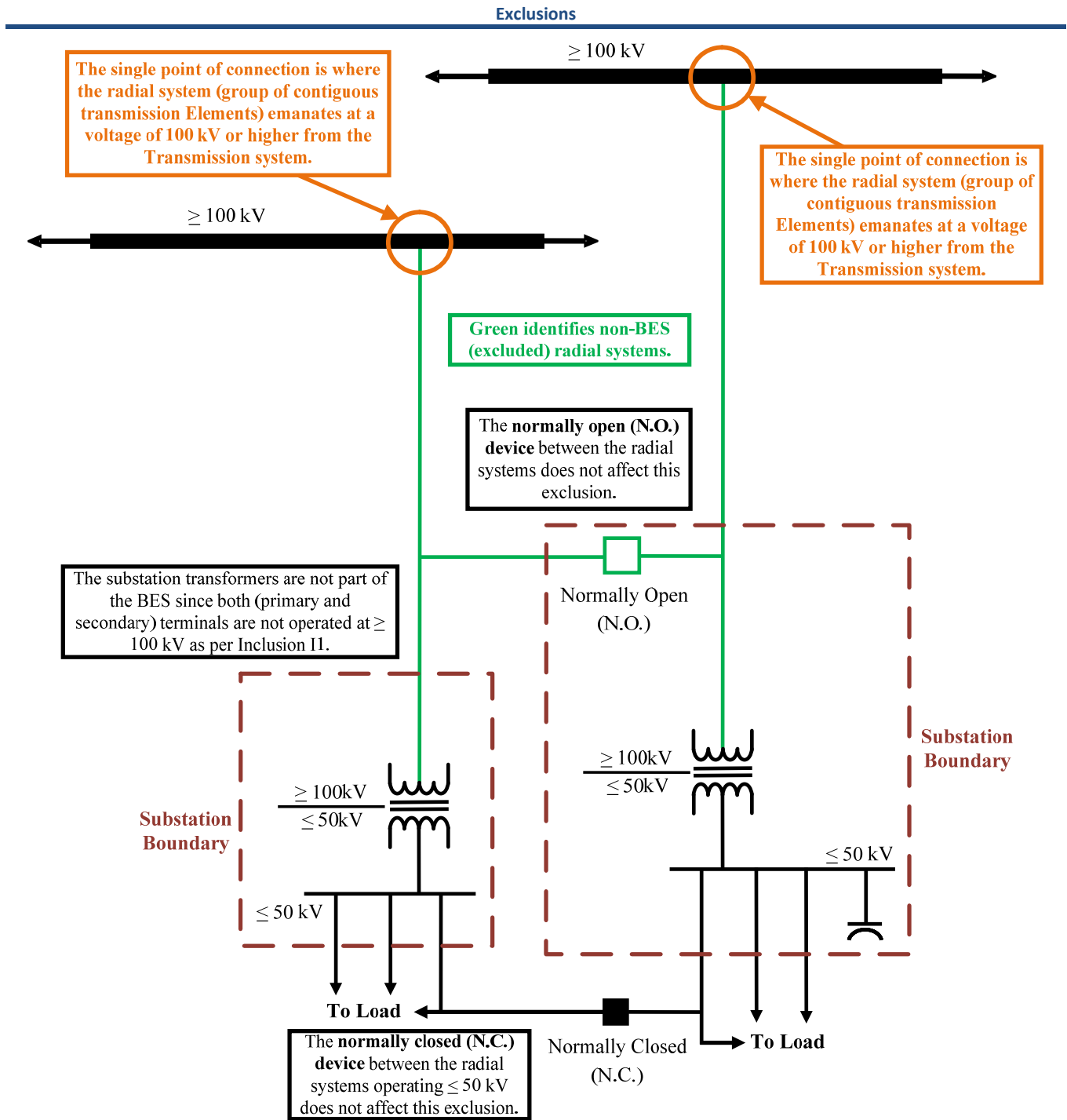

Figure E1-17: Radial System: Normally Open Switching Device between Load Serving Radial Systems with a $\leq 50\text{ kV}$ Loop

Figure E1-18 depicts a situation which cannot be evaluated under the criteria established in Exclusion E1 and can only be evaluated under the Exclusion E3 criteria since the underlying loop is ≥ 50 kV (see Figure E3-6).

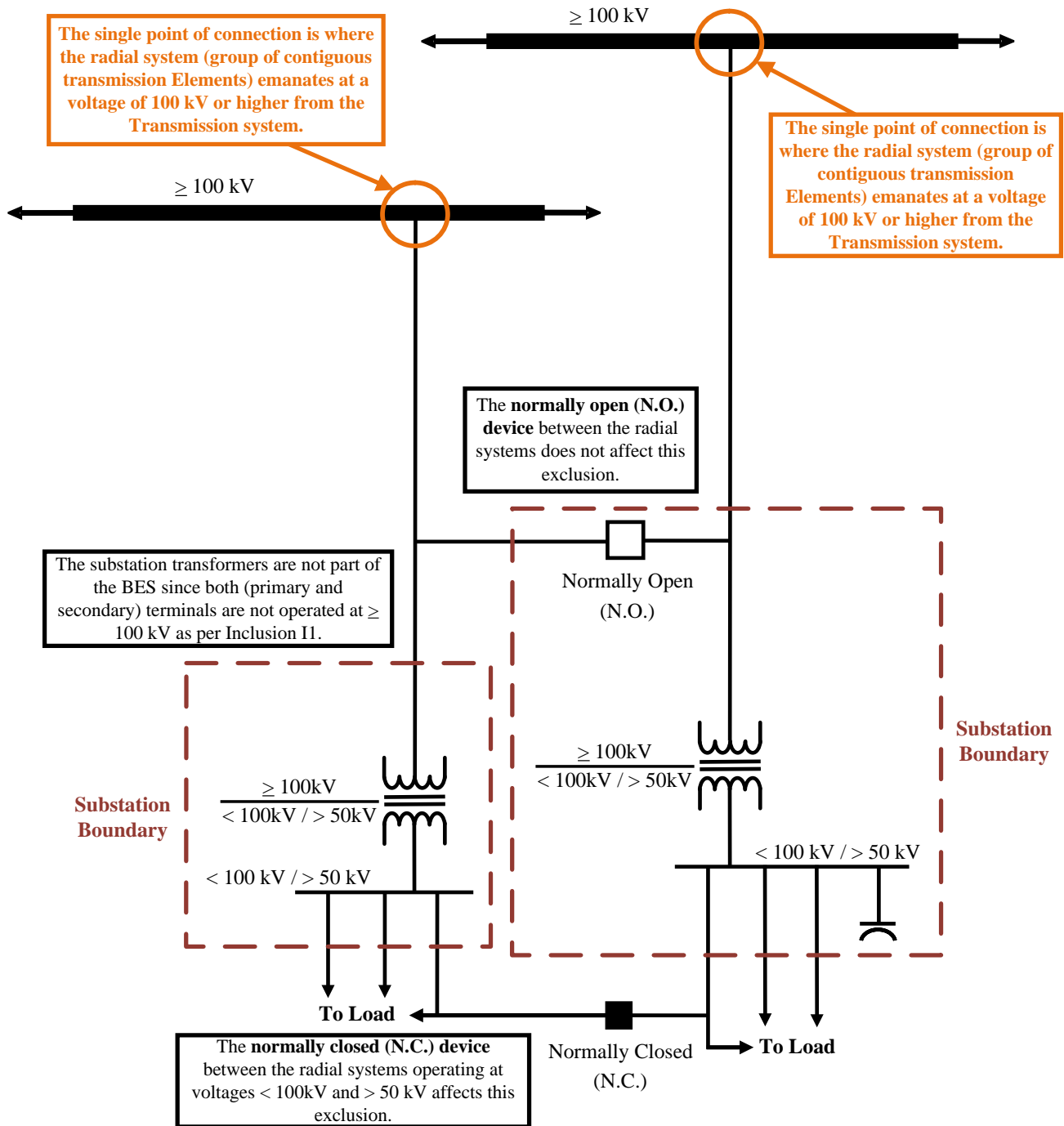

Figure E1-18: Impact of Sub-100 kV Looped Facilities (Switching Devices Identified N.O. ≥ 100 kV & N.C. < 100 kV & > 50 kV)

Figure E1-19 depicts multiple radial systems with a N.C. switching device operated at 100 kV or above with an underlying loop operating at voltages less or equal to 50 kV.

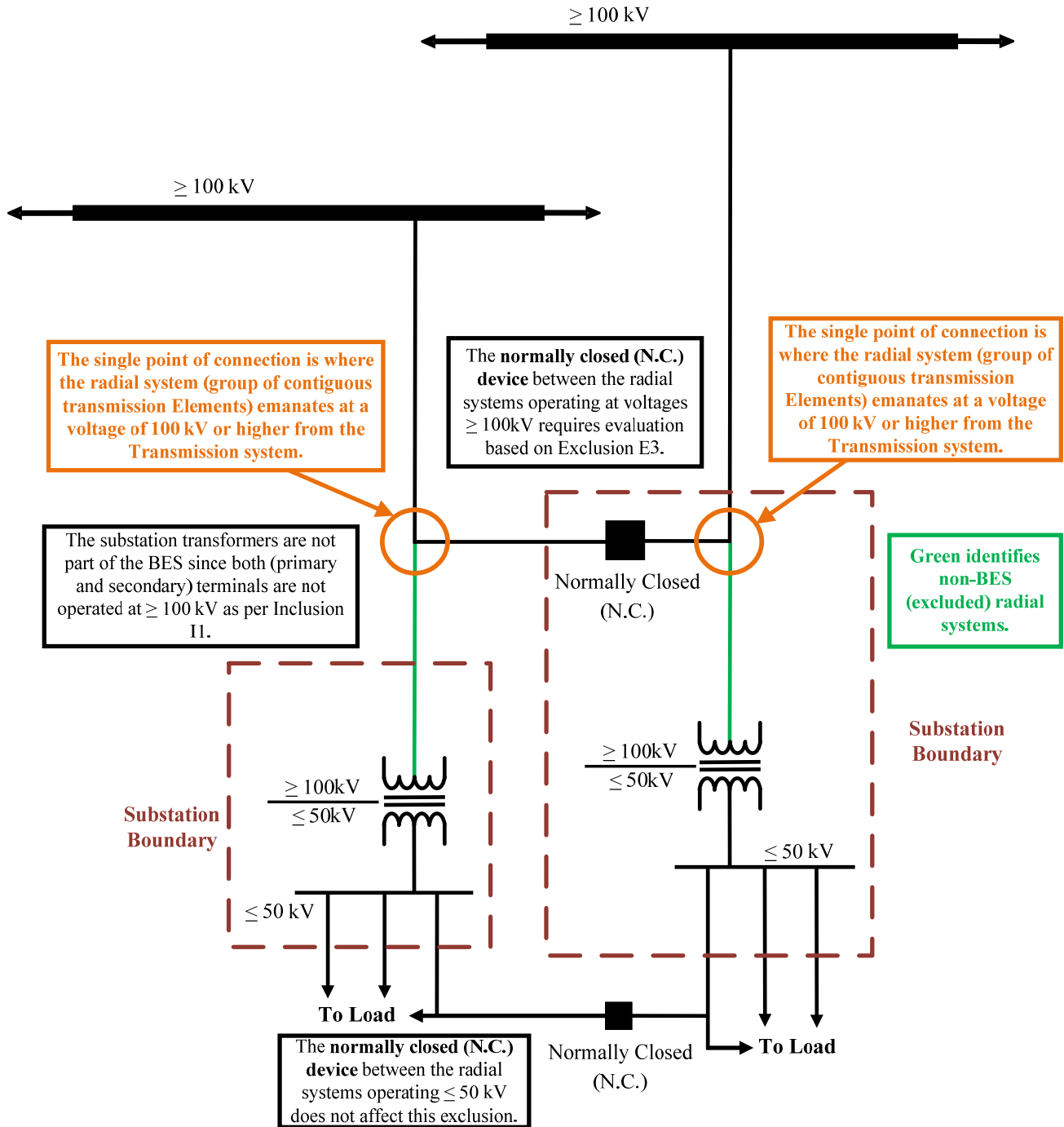

Figure E1-19: Radial System: Normally Closed Switching Device (≥ 100 kV) between Load Serving Radial Systems with a ≤ 50 kV Loop

Figure E1-20 depicts a situation which cannot be evaluated under the criteria established in Exclusion E1 and can only be evaluated under the Exclusion E3 criteria since the underlying loop is > 50 kV (see Figures E3-8).

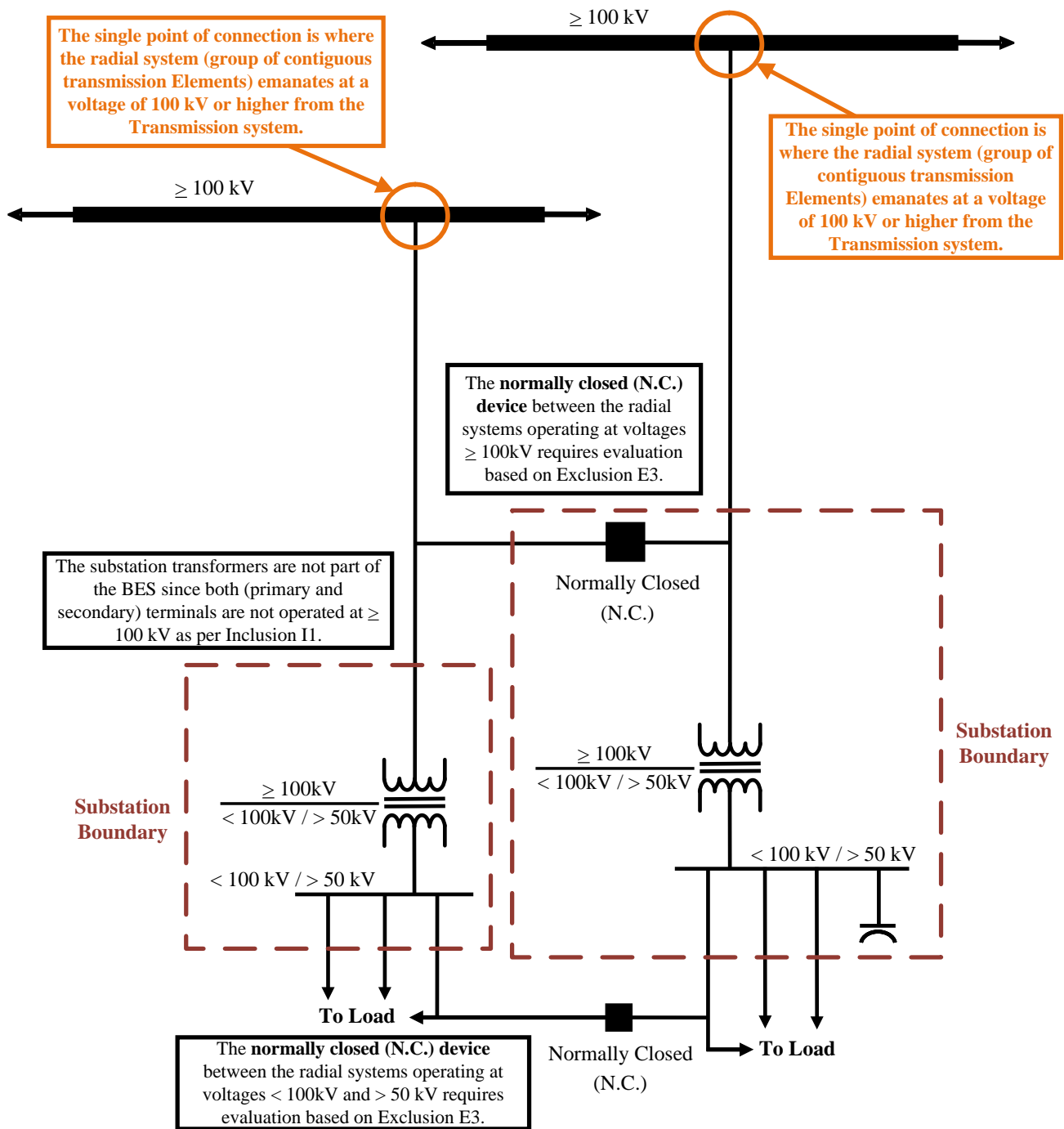

Figure E1-20: Impact of Sub-100 kV Looped Facilities (Switching Devices Identified N.C. ≥ 100 kV & N.C. < 100 kV & > 50 kV)

III.2 BES Exclusion E2

E2. A generating unit or multiple generating units on the customer’s side of the retail meter that serve all or part of the retail customer Load with electric energy on the customer’s side of the retail meter if: (i) the net capacity provided to the BES does not exceed 75 MVA, and (ii) standby, back-up, and maintenance power services are provided to the generating unit or multiple generating units or to the retail Load by a Balancing Authority, or provided pursuant to a binding obligation with a Generator Owner or Generator Operator, or under terms approved by the applicable regulatory authority.

Exclusion E2 provides for the exclusion of the Real Power resources that reside behind the retail meter (on the customer’s side) and supersedes Inclusion I2. The exclusion is a restatement of the exclusion in Section III.c.4 of the *ERO Statement of Compliance Registry Criteria (v.5)*, as clarified by the SDT in response to industry comments and recommendations:

“As a general matter, a customer-owned or operated generator/generation that serves all or part of retail load with electric energy on the customer’s side of the retail meter may be excluded as a candidate for registration based on these criteria if (i) the net capacity provided to the Bulk-Power System does not exceed the criteria above or the Regional Entity otherwise determines the generator is not material to the Bulk-Power System and (ii) standby, back-up and maintenance power services are provided to the generator or to the retail load pursuant to a binding obligation with another generator owner/operator or under terms approved by the local regulatory authority or the Federal Energy Regulatory Commission, as applicable.”

Exclusion E2 is dedicated to the situation faced by behind-the-meter (i.e., retail customer owned) generation that are qualifying facilities as defined by the Public Utility Regulatory Policies Act (PURPA) in the US (e.g., see 18 CFR Part 292 for the regulations that are applicable in the US), and similarly situated facilities in Canada. These facilities—often referred to as combined heat and power (CHP) facilities—are commonly employed at petroleum refineries, chemical and food processing plants, pulp and paper mills, steel mills, and large commercial applications requiring both electrical and thermal energy.

The primary purpose of retail customer owned generation in the context of Exclusion E2 is the integrity of steam production that supports a manufacturing process. The electrical Load of that host process does not exist without steam. However, Exclusion E2 might apply to other situations as well.

Exclusion E2 references the net generation (in MWs) since that is how the generation is operated, and the residual (“net”) amount exported to the BES is what is deemed relevant to the exclusion and reliability, not the nameplate rating in MVA. The Real Power (physical) export is subject to a 75 MVA threshold. Condition (ii) in Exclusion E2 is derived from FERC or provincial regulations applicable to qualifying cogeneration and small power production facilities (i.e., QFs). For example, see 18 CFR §292.101 and §292.305(b) for the requirements specific to the US. Condition (ii) requires that the generation serving the retail customer Load self-provide reserves (i.e., standby, backup, and maintenance power), and is essential for the integrity of the exclusion. These reserves maintain steam generation and the load to sustain the manufacturing process. In the US, the terms and conditions of standby, backup, and maintenance services are defined and administered by State Public Service Commissions (PSC) (i.e., the “applicable regulatory authority” in the US) subject to FERC oversight. These services are provided under contract or tariff with Generator Owners, Generator Operators, or Balancing Authorities in regions that do not have Independent System Operators (ISOs) or Regional Transmission Operators (RTOs), and provided by ISOs and RTOs where “organized markets” operate. These terms and conditions will be understood in Balancing Authority Areas where it is applicable, as it reflects existing industry practice.

Multiple connection points to the BES do not preclude the use of Exclusion E2.

Net capacity

The net capacity determination for Exclusion E2 is the net flow to the BES as measured by integrated hourly revenue metering for the most recent 12 month period. Periods of net capacity to the BES that exceed the threshold value when directed by the applicable Balancing Authority do not preclude the ability to utilize this exclusion.

Note: Figures E2-1 and E2-2 are depictions of the application of Exclusion E2 and are intended to assist the user during the hierarchical application of the BES definition.

Figure E2-1 depicts customer owned generation residing behind the retail meter. The cogeneration operation is resulting in a net capacity to the BES of 50 MVA.

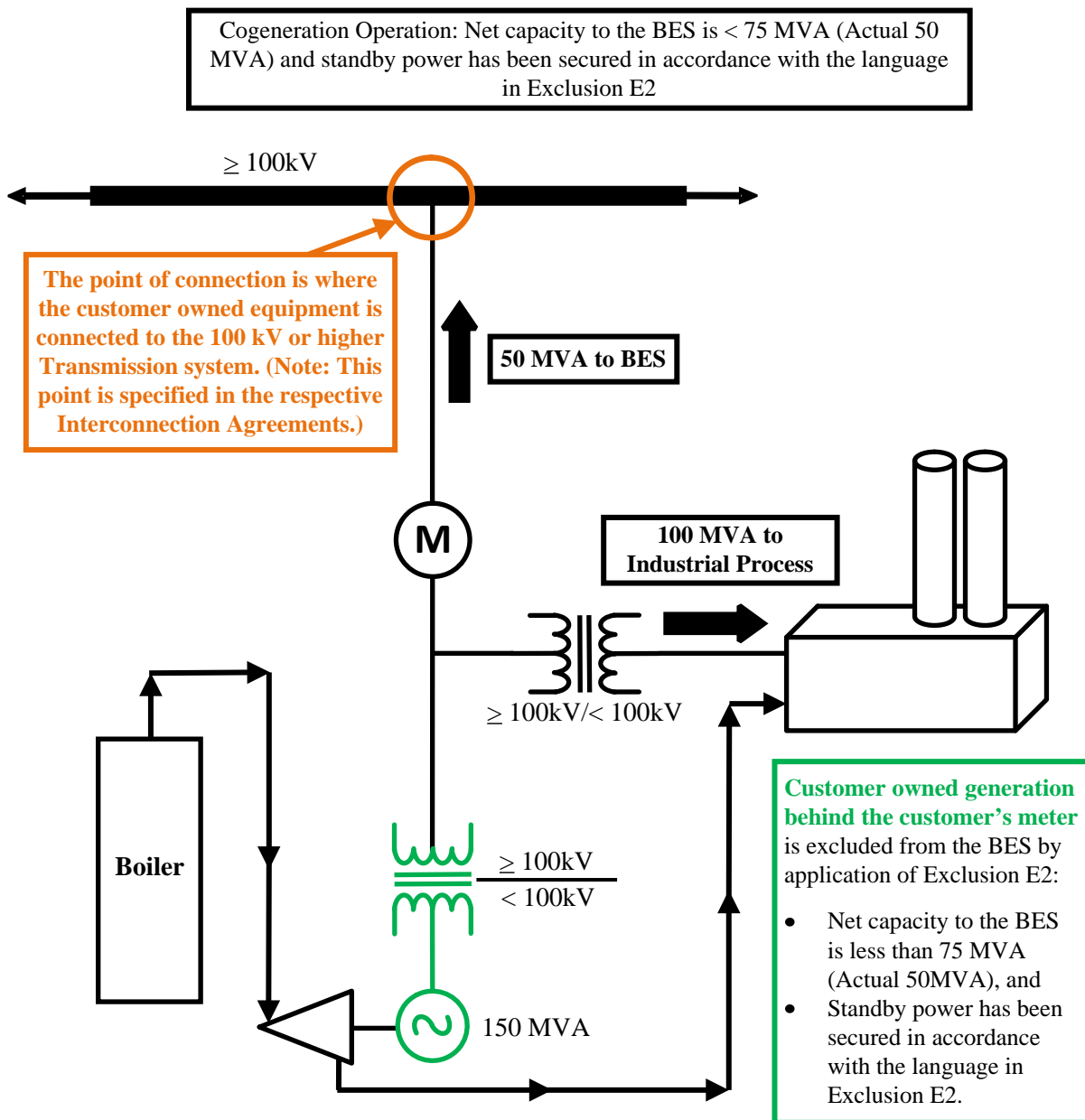

Figure E2-1: Behind-the-Meter Generation: Net Capacity to the BES Less Than 75 MVA

Figure E2-2 depicts customer owned generation residing behind the retail meter. The cogeneration operation is resulting in a net capacity to the BES of 100 MVA.

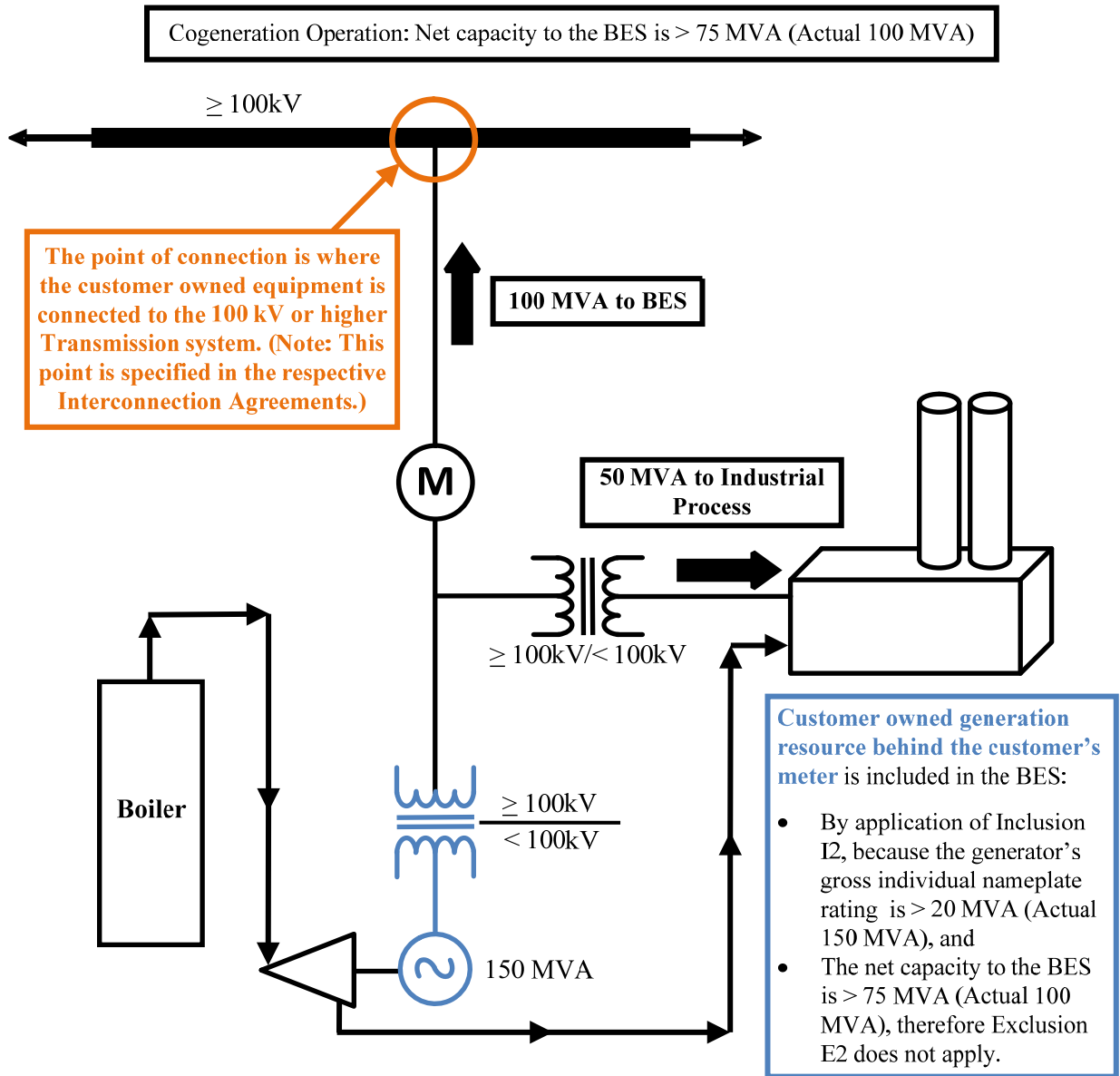

Figure E2-2: Behind-the-Meter Generation: Net Capacity to the BES Greater Than 75 MVA

III.3 BES Exclusion E3

E3. Local networks (LN): A group of contiguous transmission Elements operated at less than 300 kV that distribute power to Load rather than transfer bulk power across the interconnected system. LN's emanate from multiple points of connection at 100 kV or higher to improve the level of service to retail customers, and not to accommodate bulk power transfer across the interconnected system. The LN is characterized by all of the following:

- Limits on connected generation: The LN and its underlying Elements do not include generation resources identified in Inclusions I2, I3, or I4, and do not have an aggregate capacity of non-retail generation greater than 75 MVA (gross nameplate rating);
- Real Power flows only into the LN and the LN does not transfer energy originating outside the LN for delivery through the LN; and
- Not part of a Flowgate or transfer path: The LN does not contain any part of a permanent Flowgate in the Eastern Interconnection, a major transfer path within the Western Interconnection, or a comparable monitored Facility in the ERCOT or Quebec Interconnections, and is not a monitored Facility included in an Interconnection Reliability Operating Limit (IROL).

Exclusion E3 is an exclusion for the contiguous transmission Elements that operate at or above 100 kV but less than 300 kV and emanate from multiple points of connection at 100 kV or higher. The local network exclusion is not dependent on the existence of a switching device at the points of connection to the BES (i.e., automatic interrupting device, manual disconnects, etc.). Generation resources connected within the local network, power flow criteria, and Element classification (i.e., Flowgate, transfer path) are qualifiers for this exclusion.

Exclusion E3 does not allow for the exclusion of generation resources that meet the criteria for generation resources as described in Inclusions I2, I3, and I4. Reactive resources that meet the criteria described in Inclusion I5 cannot be excluded by application of Exclusion E3. The presence of Reactive resources does not preclude the ability to invoke Exclusion E3. Exclusion E3 allows for the exclusion of contiguous transmission Elements (i.e., transformers, circuit breakers, bus sections, and transmission lines) emanating from multiple points of connection at a voltage of 100 kV or higher.

The power flow criterion describes the Real-time operational characteristics of the local network. And, by definition, the local network, cannot be part of a designated Flowgate or transfer path.

FERC Order No. 773 directed implementation of the revised BES definition to take into account the impact of sub-100 kV looped Facilities regardless of voltage level altering previous guidance on the evaluation of local networks. This meant that if there was a connection at the sub-100 kV level between two systems that would previously have been considered as radial, said systems could not be evaluated for possible radial system exclusion. However, the drafting team developed a technical justification establishing 50 kV as a threshold value for sub-100 kV looped facilities. If the sub-100 kV loop is 50 kV or less, it was shown that it would not have an impact on the BES and thus an entity could still apply Exclusion E1 to the configuration. If the loop in question was greater than 50 kV, then an entity could not consider the systems as radial and would need to evaluate them under the criteria of Exclusion E3 if seeking to exclude the Facilities from the BES.

The evaluation of sub-100 kV loops associated with the evaluation of Elements under the E3 exclusion is used as a “qualifier” for the potential exclusion of the Elements that operate at or above 100 kV.

- Failure to meet the “bright-line” criteria established by Exclusion E3 does not result in the inclusion of the sub-100 kV loops in the BES.

- Order No. 773, paragraph 155 states:
“Thus, the Commission, while disagreeing with NERC’s interpretation, does not propose to include the below 100 kV elements in figure 3 in the bulk electric system, unless determined otherwise in the exception process.”
- Order No. 773-A, paragraph 36 states:
“Moreover, as noted in the Final Rule, the sub-100 kV elements comprising radial systems and local networks will not be included in the bulk electric system, unless determined otherwise in the exception process.”

Entities should be prepared to justify local network determinations.

Reactive Resources

Reactive resources that meet the criteria described in Inclusion I5 cannot be excluded by application of Exclusion E3. The presence of reactive resources does not preclude the ability to invoke Exclusion E3.

Generation Limits

There are two conditions under which generation resources can prevent a network from qualifying for Exclusion E3:

1. The aggregate nameplate capacity of the non-retail generation capacity within the network in question exceeds 75 MVA; or
2. Any generation within the local network in question is identified in Inclusion I2, I3, or I4.

If either of these conditions applies, the network does not qualify for Exclusion E3.

Power Flow at BES Interface

An entity who determines that all or a portion of its Facilities meet the local network exclusion should be able to demonstrate, by inspection of actual system data, that flow of power is always into the local network at each point of interface with the BES at all times. The SDT’s intent was that hourly integrated power flow values over the course of the most recent two-year period would be sufficient to make such a demonstration.

In order for transmission Elements to qualify for Exclusion E3, power flow direction at all points of BES interface must be into the local network under all operating conditions. Therefore, the second characteristic of Exclusion E3 (E3.b) that: “... the LN does not transfer energy originating outside the LN for delivery through the LN” will also be satisfied in that energy is not being transferred through the local network.

Voltage Thresholds

The local network exclusion applies to electric transmission Elements operated below 300 kV, and cannot extend to any Facilities operated above 300 kV. Facilities operated below 100 kV are excluded from the BES by application of the core definition.

If the candidate local network does not qualify for Exclusion E3, then further evaluation of the underlying Elements may be appropriate based on other criteria within the definition. Each underlying Element must meet the criteria established by Exclusion E3, including parts a, b, and c, to qualify for exclusion from the BES. Such evaluations are not shown in Figures E3-1 through E3-9, which concentrate on the bigger picture, but are detailed in the summary diagrams in Section IV where the hierarchical application of the definition is described and shown.

Note: Figures E3-1 through E3-9 are depictions of the application of Exclusion E3 and are intended to assist the user during the hierarchical application of the BES definition.

Figure E3-1 depicts an excluded local network which contains retail and non-retail generation resources and also serves Load. The local network operates at a voltage of 138 kV and has non-retail generation resources with an aggregate nameplate rating of 40 MVA and power only flows into the local network at each point of connection.

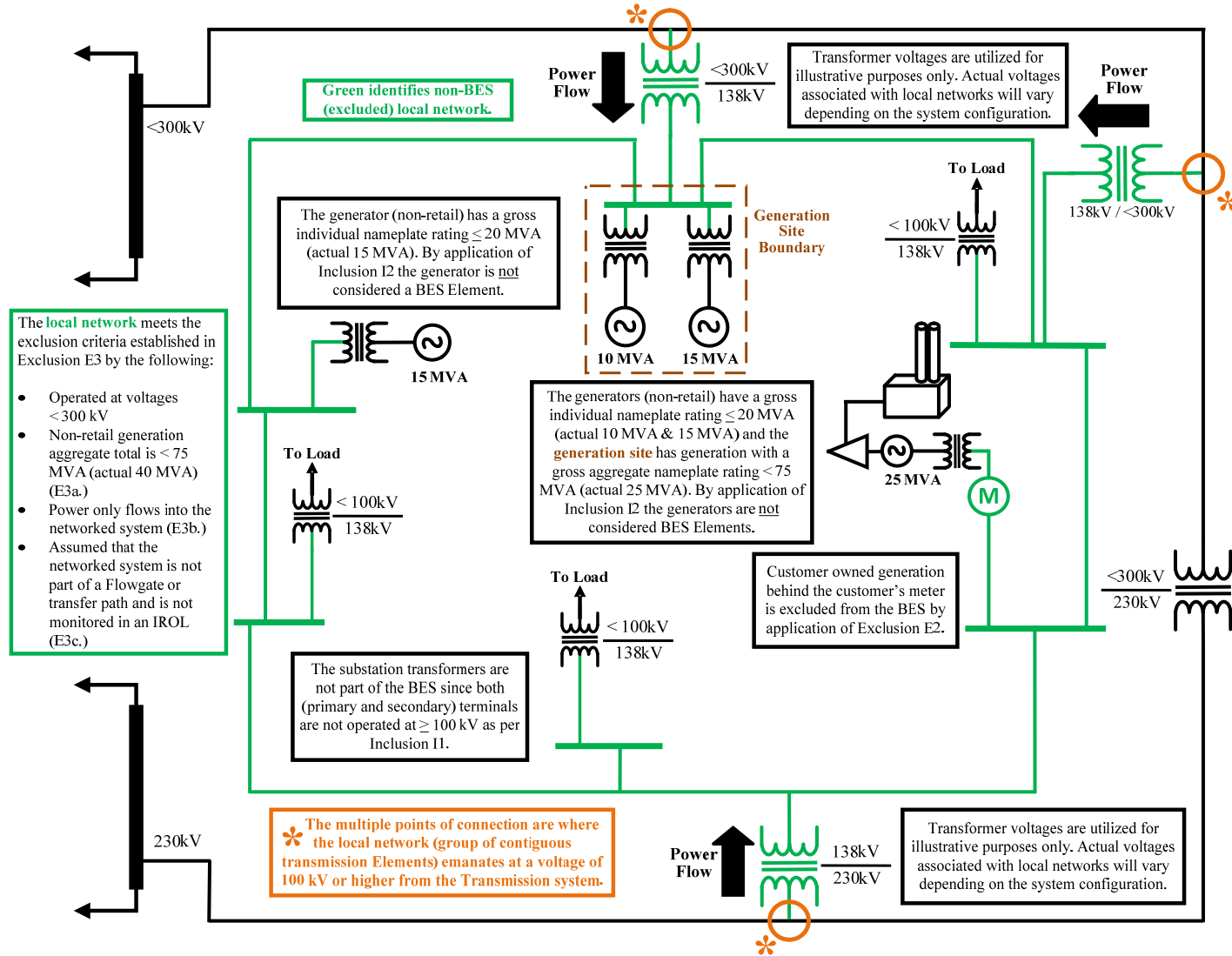

Figure E3-1: Local Network (non-BES) with Retail & Non-Retail Generation Resources & Serving Load

Figure E3-2 shows how the presence of a BES generator affects the status of a potential local network. Note that further evaluation of underlying elements may be required to complete the full application of the definition. As noted above, such evaluation is not shown in the individual sections of this document but may be seen in the system diagrams.

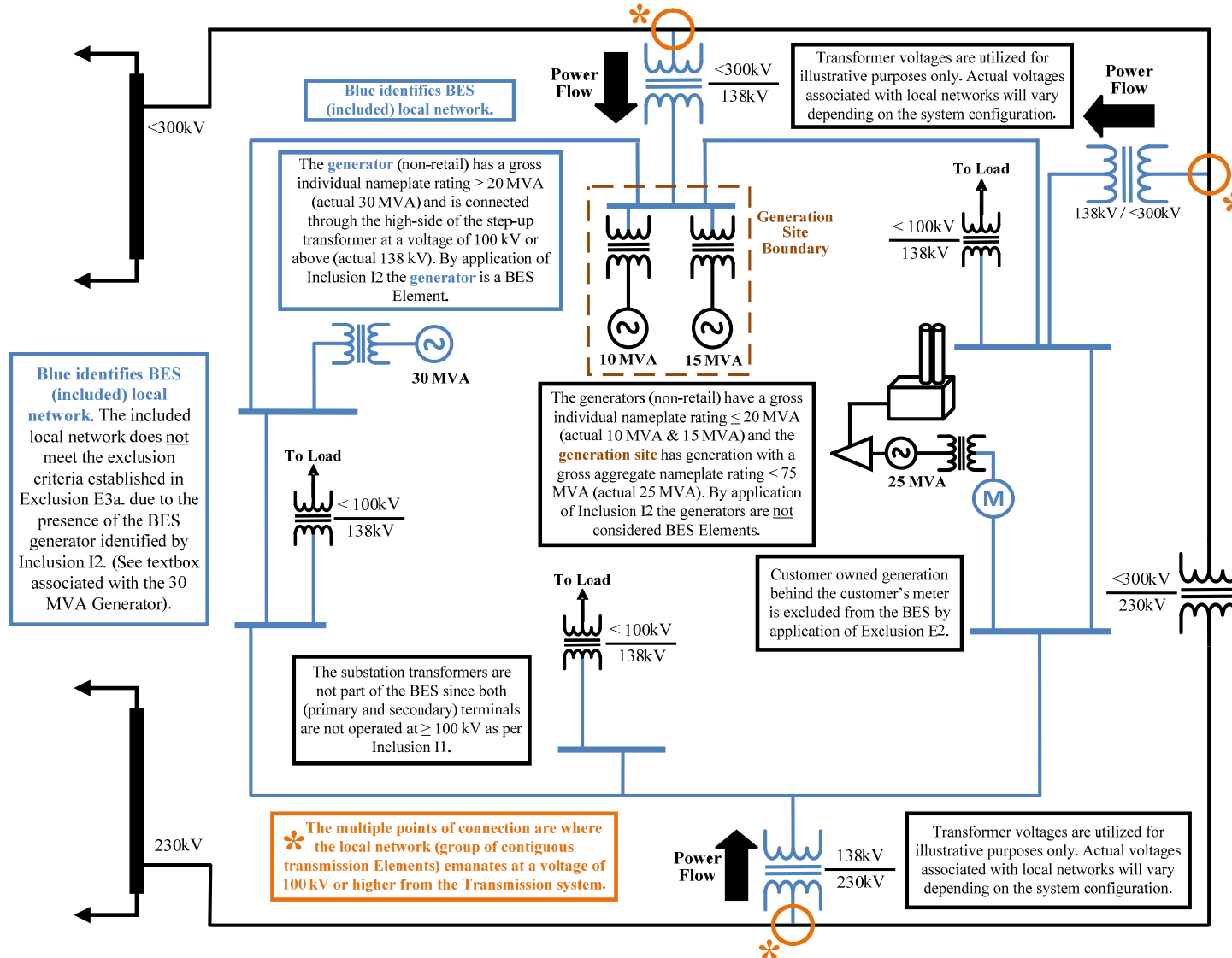

Figure E3-2: Local Network (BES) with Retail & Non-Retail Generation Resources & Serving Load

Figure E3-3 depicts a local network which contains retail and non-retail generation resources and also serves Load. The local network does not meet the criteria established by Exclusion E3 in that power flows out of the local network at one of the points of connection to the interconnected Transmission system. Note that further evaluation of underlying elements may be required to complete the full application of the definition. As noted above, such evaluation is not shown in the individual sections of this document but may be seen in the system diagrams.

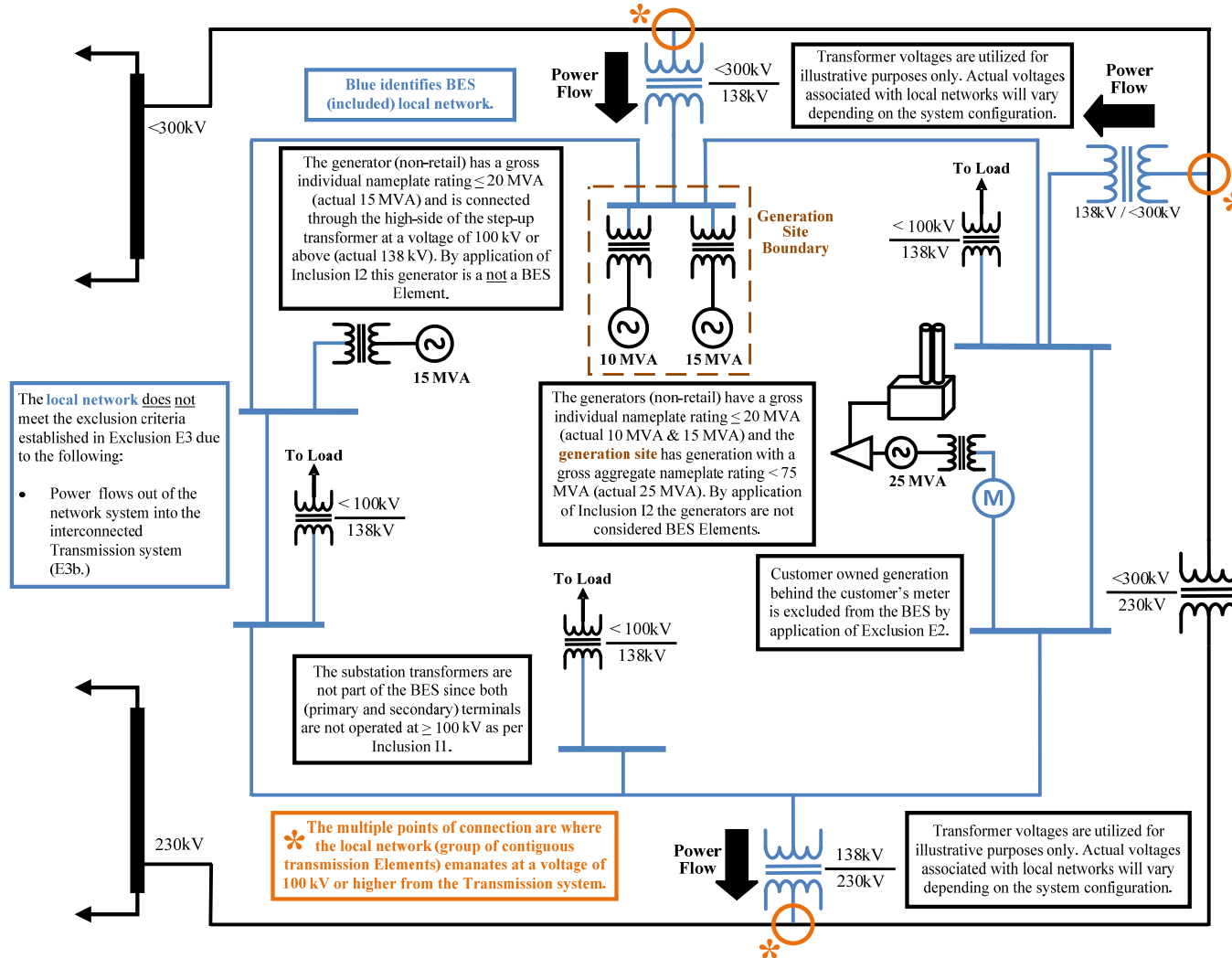

Figure E3-3: Local Network (BES) with Retail & Non-Retail Generation Resources & Serving Load

FERC Order No. 773 directed implementation of the revised BES definition to take into account the impact of sub-100 kV looped Facilities regardless of voltage level altering previous guidance on the evaluation of radial systems. This meant that if there was a connection at the sub-100 kV level between two systems that would previously have been considered as radial, said systems could not be evaluated for possible radial system exclusion. However, the drafting team developed a technical justification establishing 50 kV as a threshold value for sub-100 kV looped facilities. If the sub-100 kV loop is 50 kV or less, it was shown that it would not have an impact on the BES and thus an entity could still apply Exclusion E1 to the configuration. If the loop in question was greater than 50 kV, then an entity could not consider the systems as radial and would need to evaluate them under the criteria of Exclusion E3 if seeking to exclude the Facilities from the BES.

The evaluation of sub-100 kV loops associated with the evaluation of Elements under the E3 exclusion is used as a “qualifier” for the potential exclusion of the Elements that operate at or above 100 kV.

- Failure to meet the “bright-line” criteria established by Exclusion E3 does not result in the inclusion of the sub-100 kV loops in the BES.
- Order No. 773, paragraph 155 states:
“Thus, the Commission, while disagreeing with NERC’s interpretation, does not propose to include the below 100 kV elements in figure 3 in the bulk electric system, unless determined otherwise in the exception process.”
- Order No. 773-A, paragraph 36 states:
“Moreover, as noted in the Final Rule, the sub-100 kV elements comprising radial systems and local networks will not be included in the bulk electric system, unless determined otherwise in the exception process.”

Note: Figures E3-4 through E3-9 depict scenarios that require evaluation based on the criteria established in the BES definition as revised by the FERC Order and described above.

Figure E3-4 depicts a situation which requires evaluation based on the Exclusion E3 criteria (see Figure E1-3).

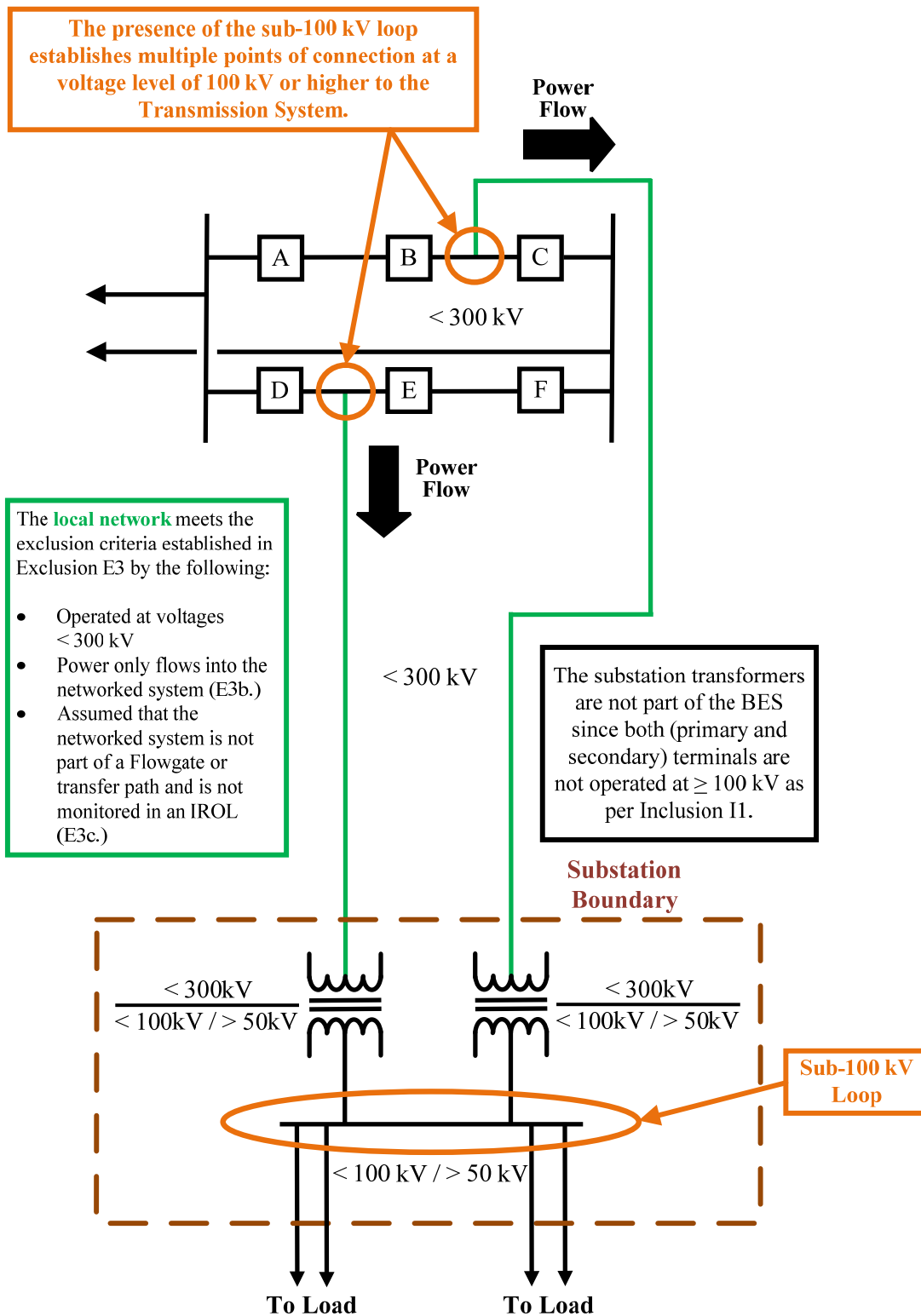

Figure E3-4: Local Network (non-BES) with Sub-100 kV Loop

Figure E3-5 duplicates the configuration of Figure E3-4, however since power is flowing out of the potential local network, this configuration does not qualify as a local network based on the Exclusion E3 criteria.

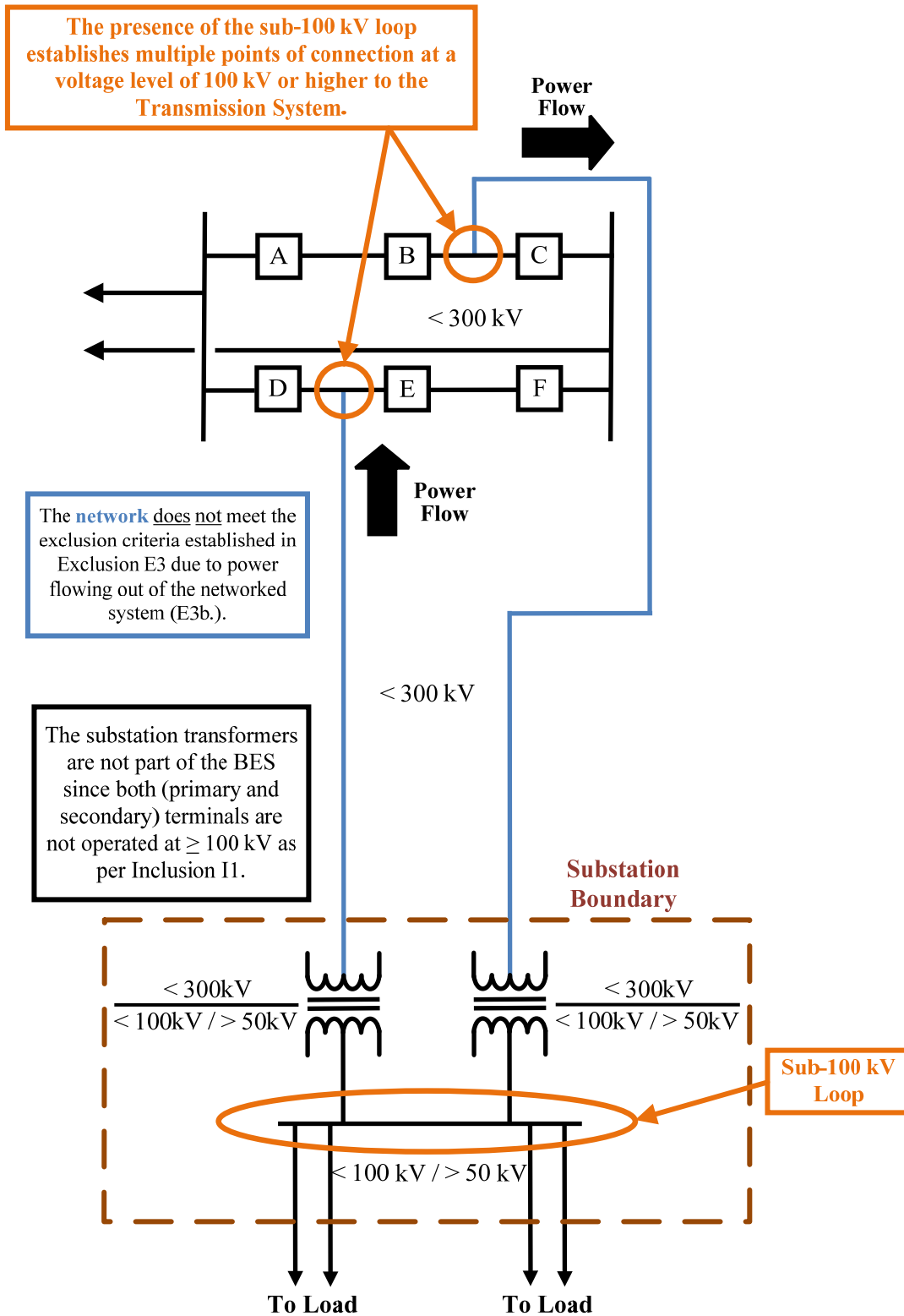

Figure E3-5: Local Network (BES) with Sub-100 kV Loop

Figure E3-6 depicts a situation which requires evaluation based on the Exclusion E3 criteria (see Figure E1-18).

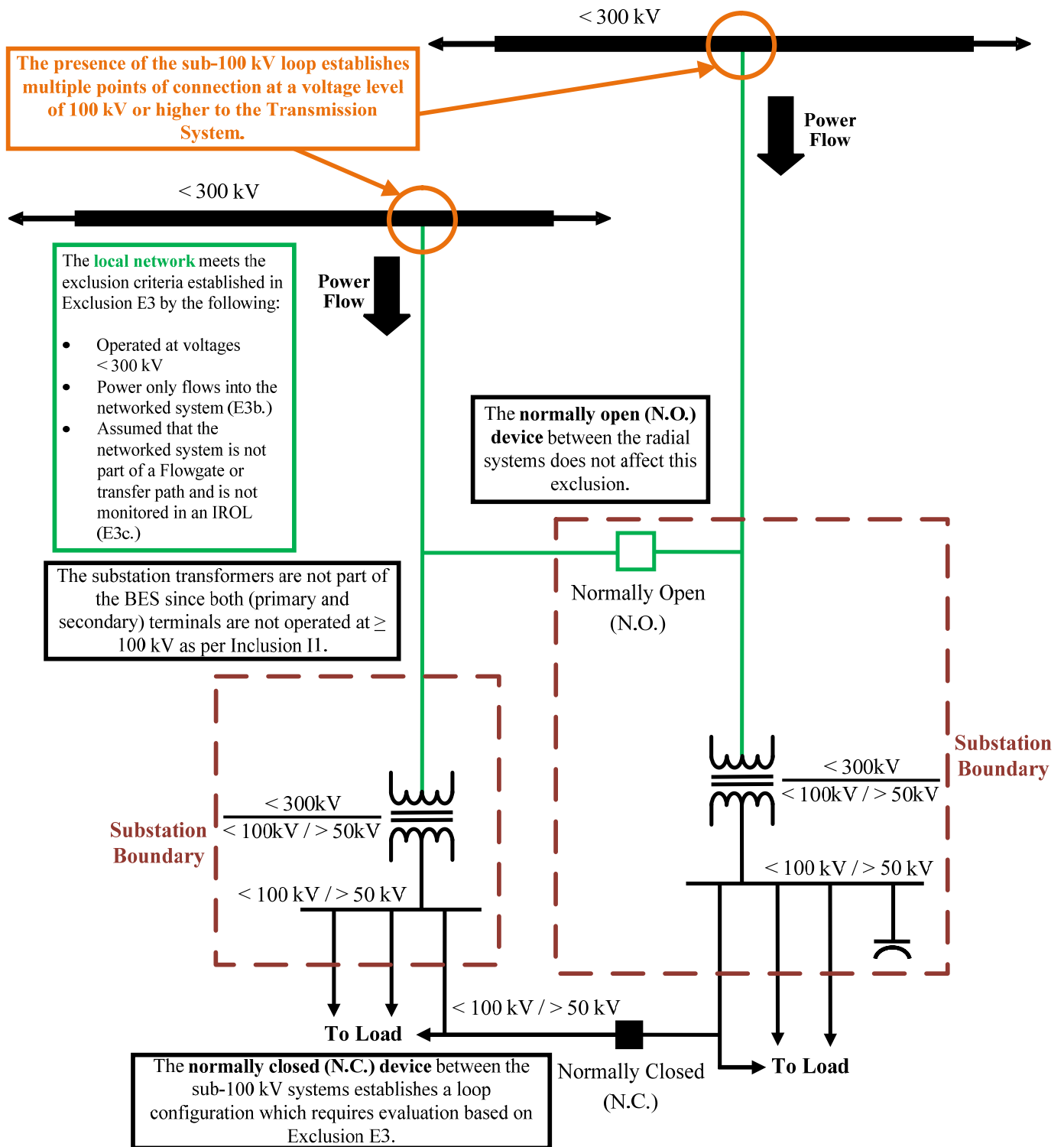

Figure E3-6: Local Network (non-BES) with Sub-100 kV Looped Facilities (Switching Devices Identified: N.O. ≥ 100 kV & N.C. < 100 kV / > 50 kV)

Figure E3-7 duplicates the configuration of Figure E3-6, however since power is flowing out of the potential local network, this configuration does not qualify as a local network based on the Exclusion E3 criteria. Since the area under consideration does not meet the criteria established by Exclusion E3, further evaluation of the underlying Elements may be appropriate. Each underlying Element must meet the criteria established by Exclusion E3, including parts a, b, or c, to qualify for exclusion from the BES. Such evaluations are not shown in Figure E3-9, which concentrates on the bigger picture, but are detailed in the summary diagrams in Section IV where the hierarchical application of the definition is described and shown.

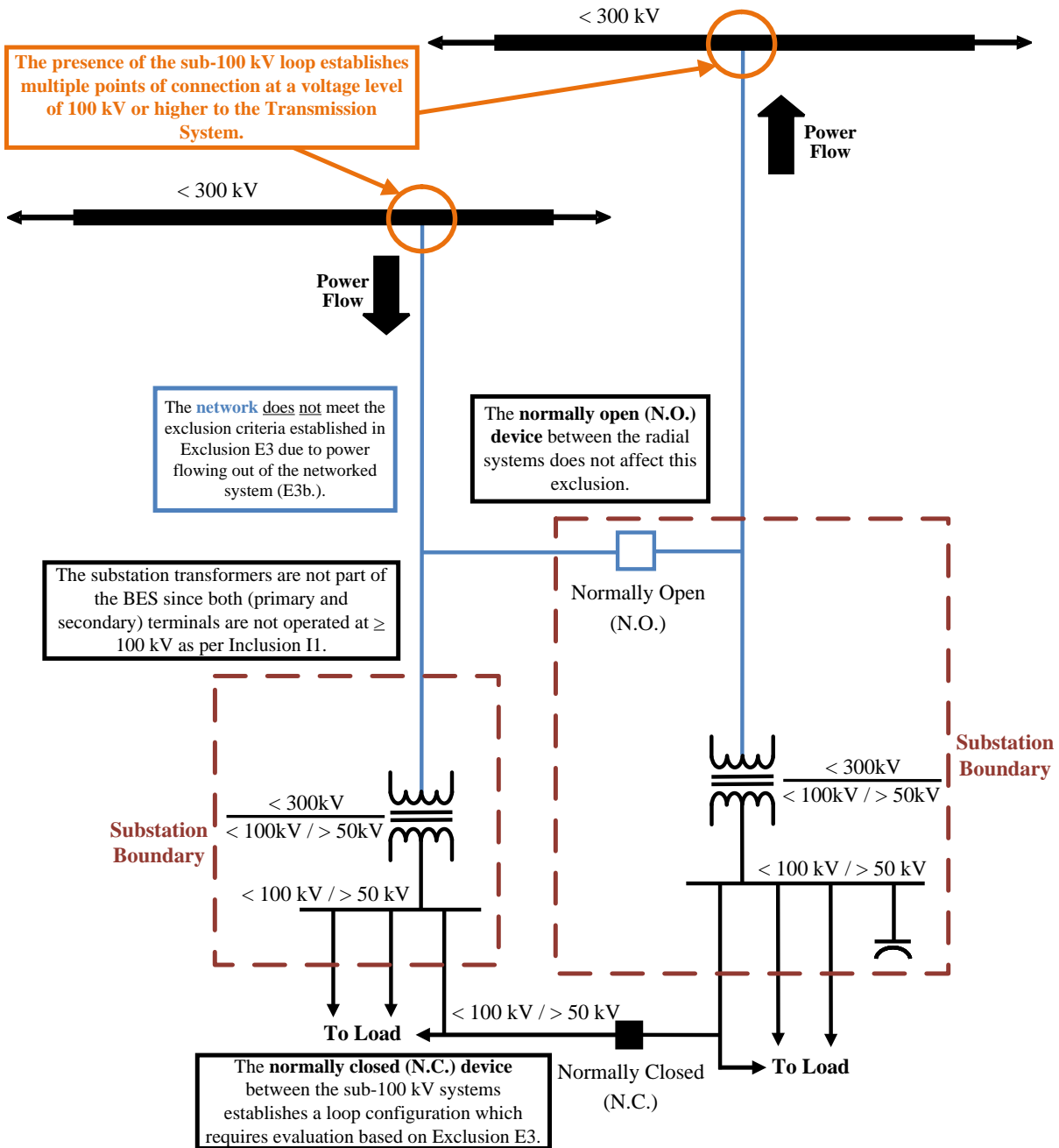

Figure E3-7: Local Network (BES) with Sub-100 kV Looped Facilities (Switching Devices Identified: N.O. ≥ 100 kV & N.C. < 100 kV/ < 50 kV)

Figure E3-8 depicts a situation where the configuration establishes multiple loops that require evaluation based on the Exclusion E3 criteria (see Figure E1-20).

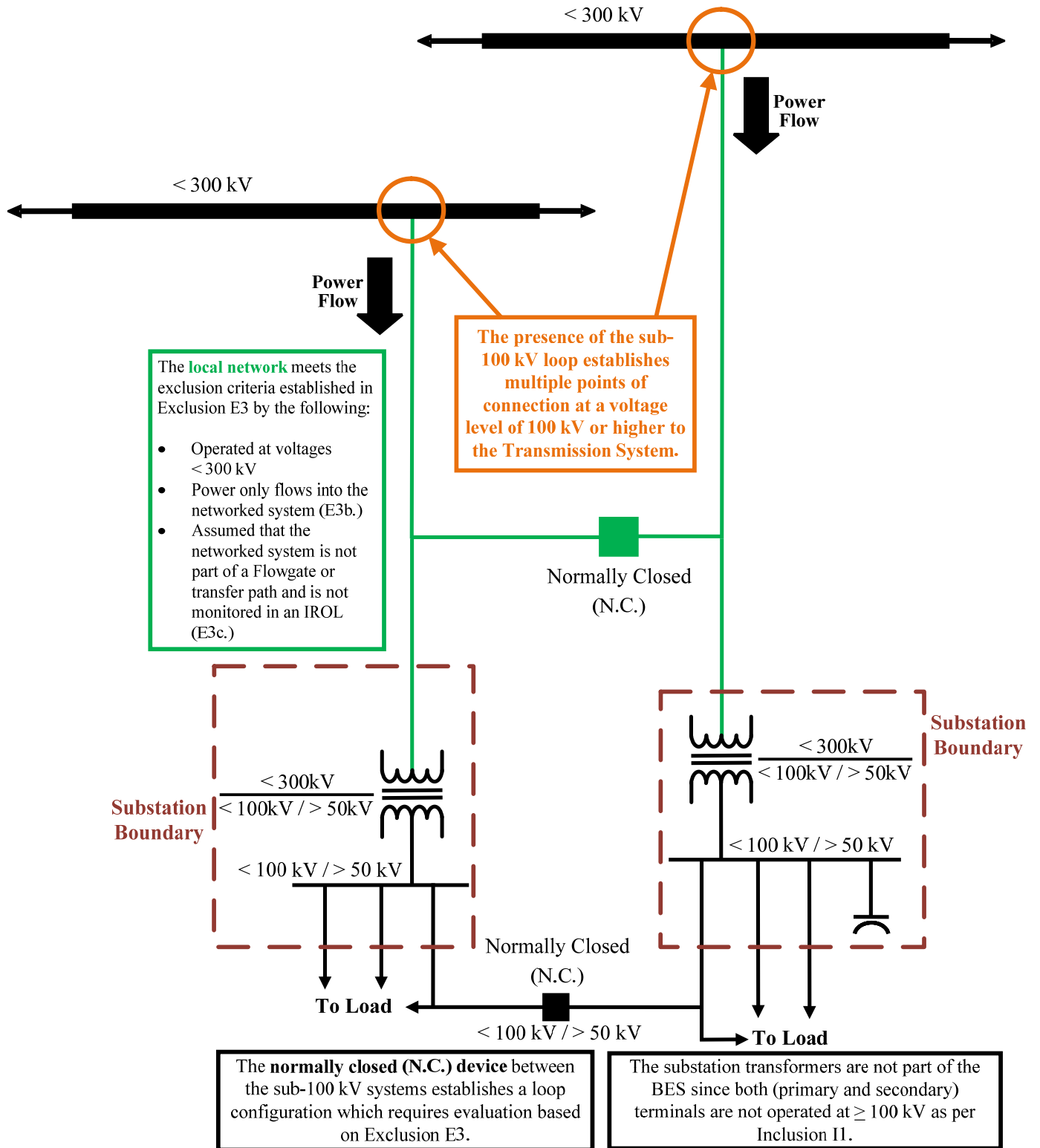

Figure E3-8: Local Network (non-BES) with Sub-100 kV Looped Facilities (Switching Devices Identified: N.C. $\geq 100\text{ kV}$ & N.C. $< 100\text{ kV} / > 50\text{ kV}$)

Figure E3-9 depicts a situation where the configuration establishes multiple loops that require evaluation based on the Exclusion E3 criteria. Since the area under consideration does not meet the criteria established by Exclusion E3, further evaluation of the underlying Elements may be appropriate. Each underlying Element must meet the criteria established by Exclusion E3, including parts a, b, or c, to qualify for exclusion from the BES. Such evaluations are not shown in Figure E3-9, which concentrates on the bigger picture, but are detailed in the summary diagrams in Section IV where the hierarchical application of the definition is described and shown.

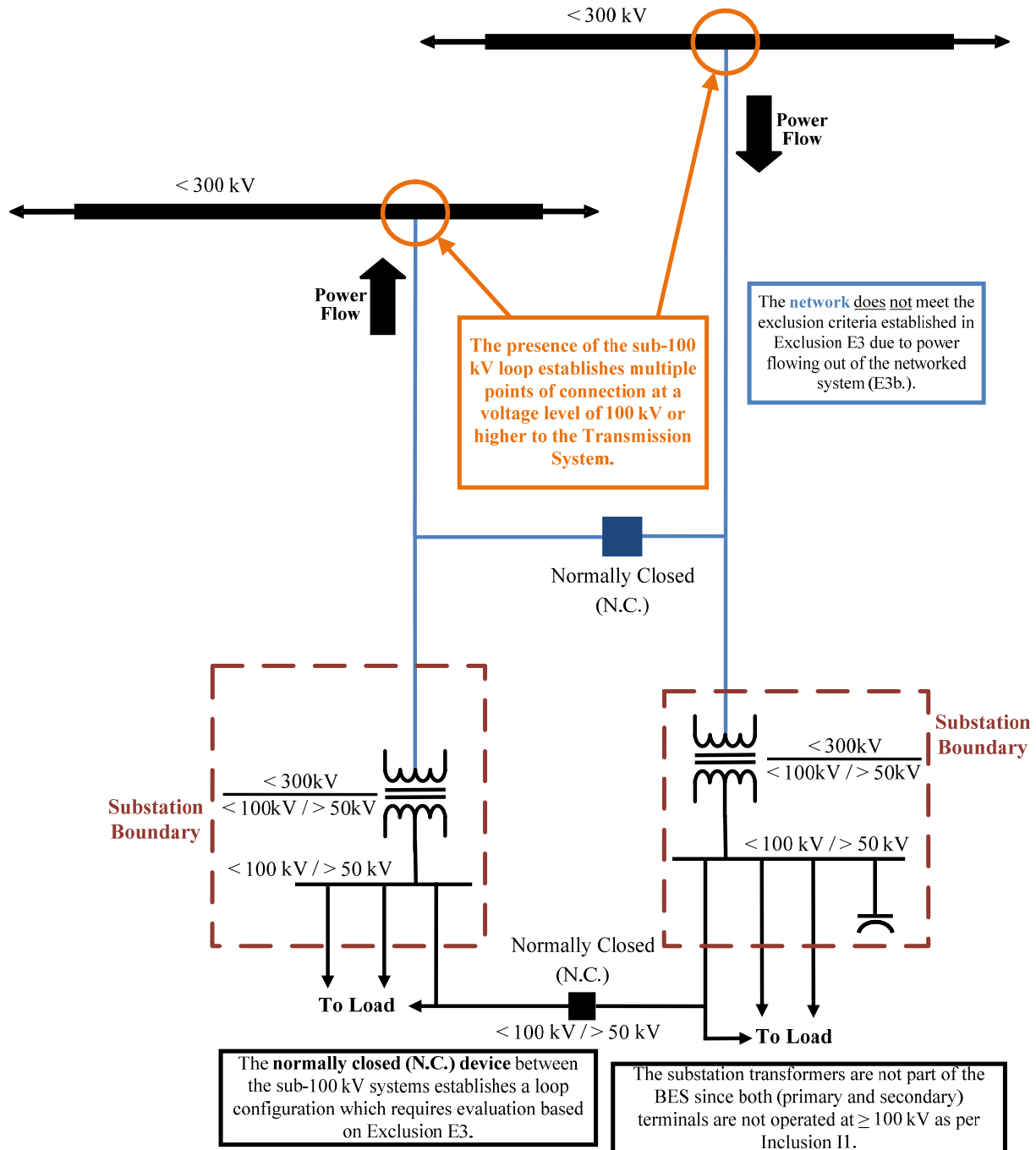

Figure E3-9: Local Network (BES) with Sub-100 kV Looped Facilities (Switching Devices Identified: N.C. ≥ 100 kV & N.C. < 100 kV/ > 50 kV)

III.4 BES Exclusion E4

E4. Reactive Power devices installed for the sole benefit of a retail customer(s).

Exclusion E4 is dependent on the intended function of the Reactive Resource; therefore, figures were not developed for Exclusion E4 due to the simplicity of the language in the exclusion.

IV. Hierarchical Application of the Definition

The hierarchical application of the definition is depicted in a series of diagrams based on a fictional system configuration and follows the sequenced application of the definition described below.

The application of the 'bright-line' BES definition is a three-step process that, when appropriately applied, will identify the vast majority of BES Elements in a consistent manner that can be applied on a continent-wide basis.

STEP 1: CORE DEFINITION: The core definition is used to establish the bright-line of 100 kV, the overall demarcation point between BES and non-BES Elements. The core BES definition identifies the Real Power and Reactive Power resources connected at 100 kV or higher, as included in the BES. To fully appreciate the scope of the core definition, an understanding of the term "Element" is needed. "Element" is defined in the NERC Glossary as: "Any electrical device with terminals that may be connected to other electrical devices such as a generator, transformer, circuit breaker, bus section, or transmission line. An element may be comprised of one or more components."

STEP 2: INCLUSIONS: This step involves applying the specific Inclusions, provides additional clarification for the purposes of identifying specific Elements that are included in the BES. The Inclusions address Transmission Elements and Real Power and Reactive Power resources with specific criteria to provide for a consistent determination of whether an Element is classified as BES or non-BES. There are five Inclusions in the Definition. The facilities described in Inclusions I1, I2, I4 and I5 are each operated (if transformers – Inclusion I1) or connected (if generating resources, dispersed power producing resources or Reactive Power resources – Inclusions I2, I4 and I5) at or above the 100 kV threshold. Inclusion I3 encompasses Blackstart Resources identified in a Transmission Operator's restoration plan, which are necessary for the reliable operation of the interconnection transmission system and should be included in the BES regardless of their size (MVA) or the voltage at which they are connected.

STEP 3: EXCLUSIONS: This step evaluates specific situations for potential exclusion from the BES. The exclusion language is written to specifically identify Elements or groups of Elements for exclusion from the BES. Step three (3) should be applied in the following sequence:

Exclusion E2 (Behind-the-Meter Generation) provides for the specific exclusion of certain Real Power resources that reside behind-the-retail meter (on the customer's side) and supersedes the more general Inclusion I2 (Generating Resources). Behind-the-meter generation that meets these specific criteria do not affect reliability of the BES because the net capacity supplied to the BES is less than 75 MVA and the specific criteria impose obligations to support reliability when the resources are unavailable.

Exclusion E4 (Reactive Power Devices) provides for the specific exclusion of Reactive Power devices installed for the sole benefit of a retail customer(s) and supersedes the more general Inclusion I5 (Static or Dynamic Reactive Power Devices). Reactive Power devices installed for the sole benefit of a retail customer are, by definition, not required for operation of the interconnected transmission system.

Exclusion E3 (Local Networks) provides for the exclusion of local networks that meet the specific criteria identified in the exclusion language. Exclusion E3 does not allow for the exclusion of Real Power and Reactive Power resources captured by Inclusions I2 through I5. In instances where a transformer (under Inclusion I1) is an Element of a local network (under Exclusion E3), the transformer would be excluded pursuant to Exclusion E3. Exclusion E3 may not be used to exclude transmission Elements (captured by the core definition and Inclusion I1) when Real Power resources are present that are captured by Inclusion I2, I3, or I4. This assures that interconnection facilities for BES generators are not excluded.

Exclusion E1 (Radial Systems) provides for the exclusion of transmission Elements from radial systems that meet the specific criteria identified in the exclusion language. Exclusion E1 does not allow for the exclusion of Real Power and Reactive Power resources captured by Inclusions I2 through I5. In instances where a transformer (under Inclusion I1) is an Element of a radial system (under Exclusion E1), the transformer would be excluded pursuant to Exclusion E1. Exclusion E1 may not be used to exclude transmission Elements (captured by the core definition and Inclusion I1) when Real Power resources are present that are captured by Inclusion I2, I3, or I4. This assures that interconnection facilities for BES generators are not excluded.

Key to diagram color coding:

- **Blue** indicates that an Element is included in the BES
- **Green** indicates that an Element is not included in the BES
- **Orange** indicates 'points of connection'
- **Black** indicates Elements that are not evaluated for the specific exclusion depicted in the individual diagrams being shown.

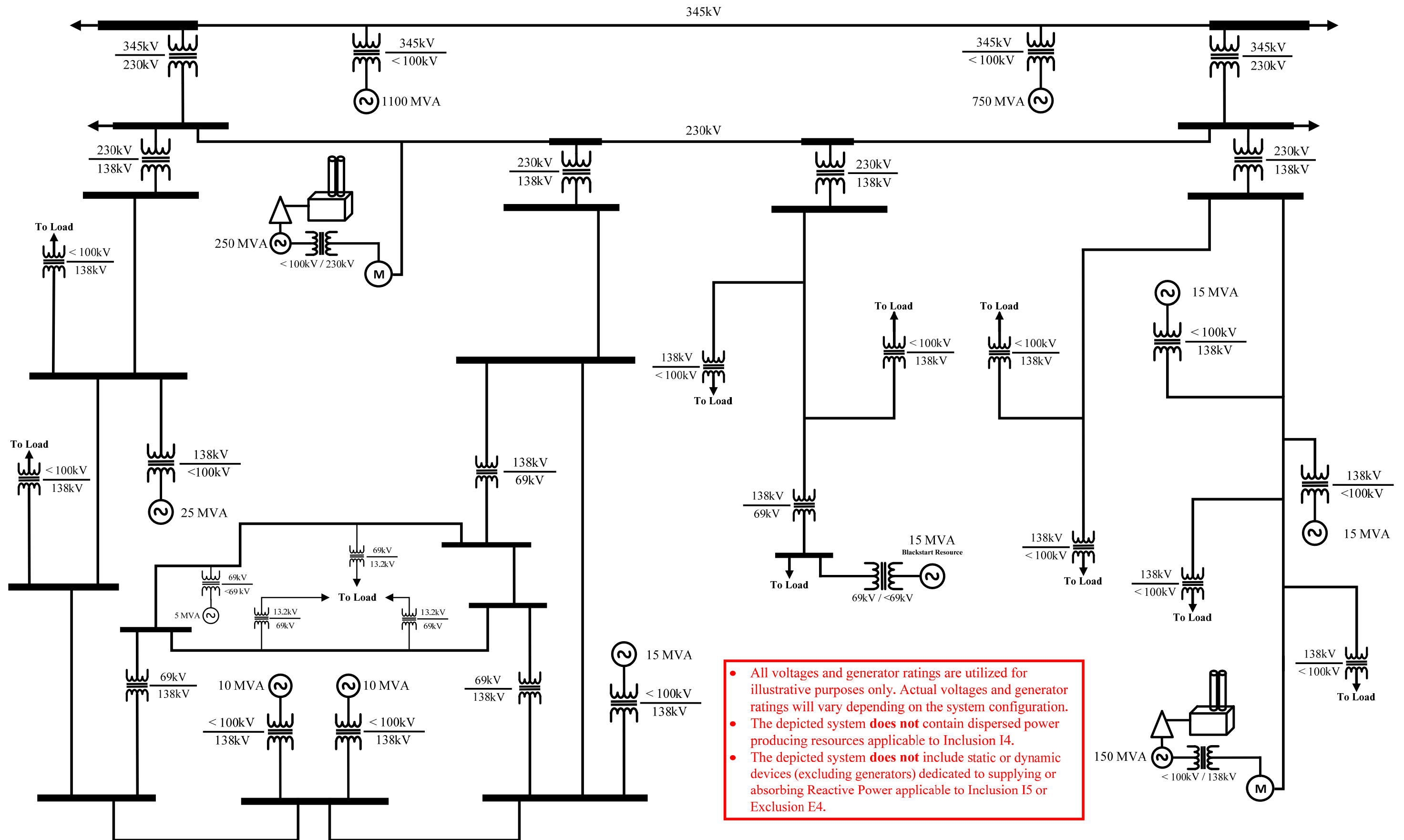

- All voltages and generator ratings are utilized for illustrative purposes only. Actual voltages and generator ratings will vary depending on the system configuration.
- The depicted system **does not** contain dispersed power producing resources applicable to Inclusion I4.
- The depicted system **does not** include static or dynamic devices (excluding generators) dedicated to supplying or absorbing Reactive Power applicable to Inclusion I5 or Exclusion E4.

Figure S1-1: System Diagram – Base Diagram

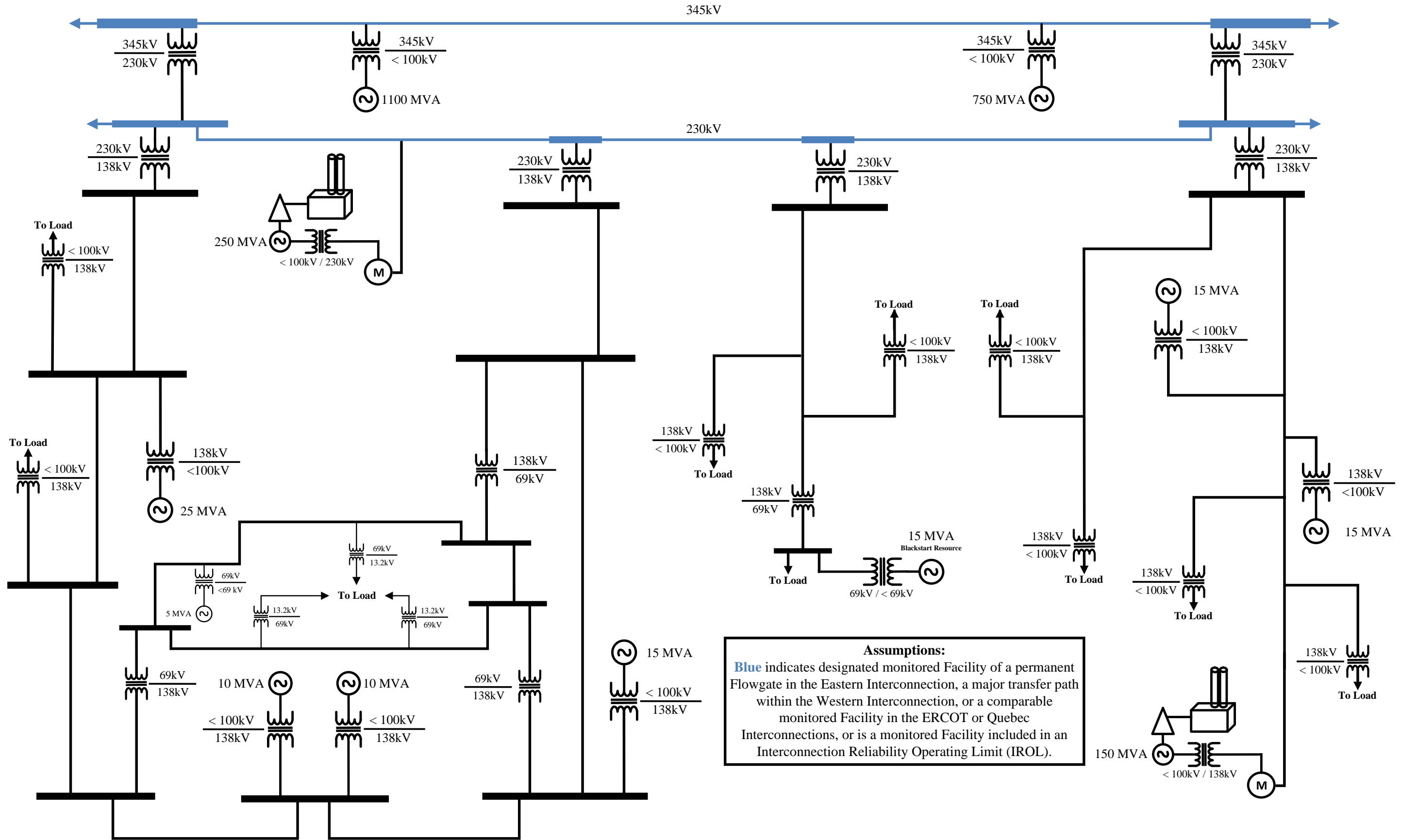

Figure S1-2: System Diagram – Assumptions

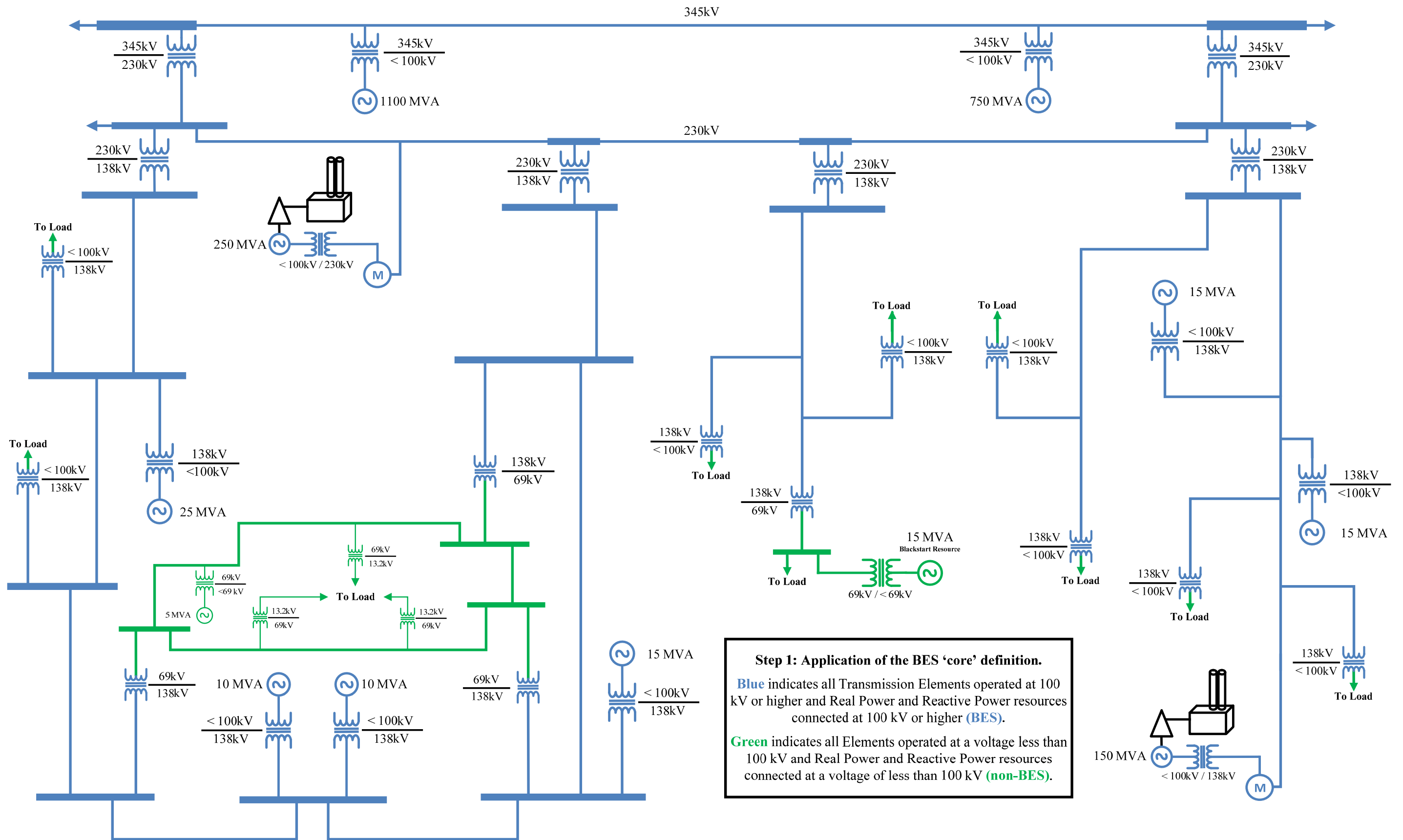

Figure S1-3: System Diagram – Application of 'Core' Definition

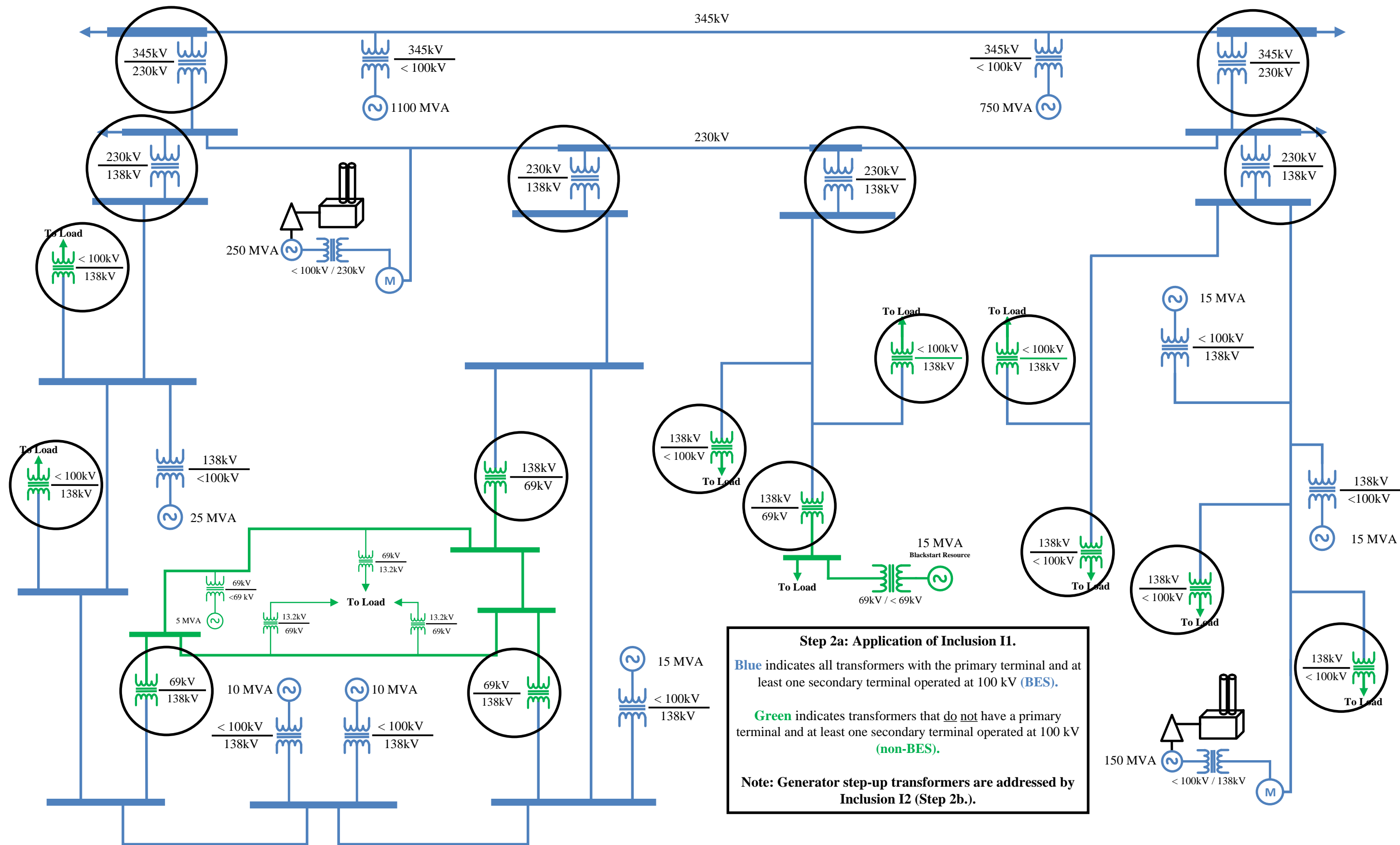

Figure S1-4: System Diagram – Application of Inclusion I1

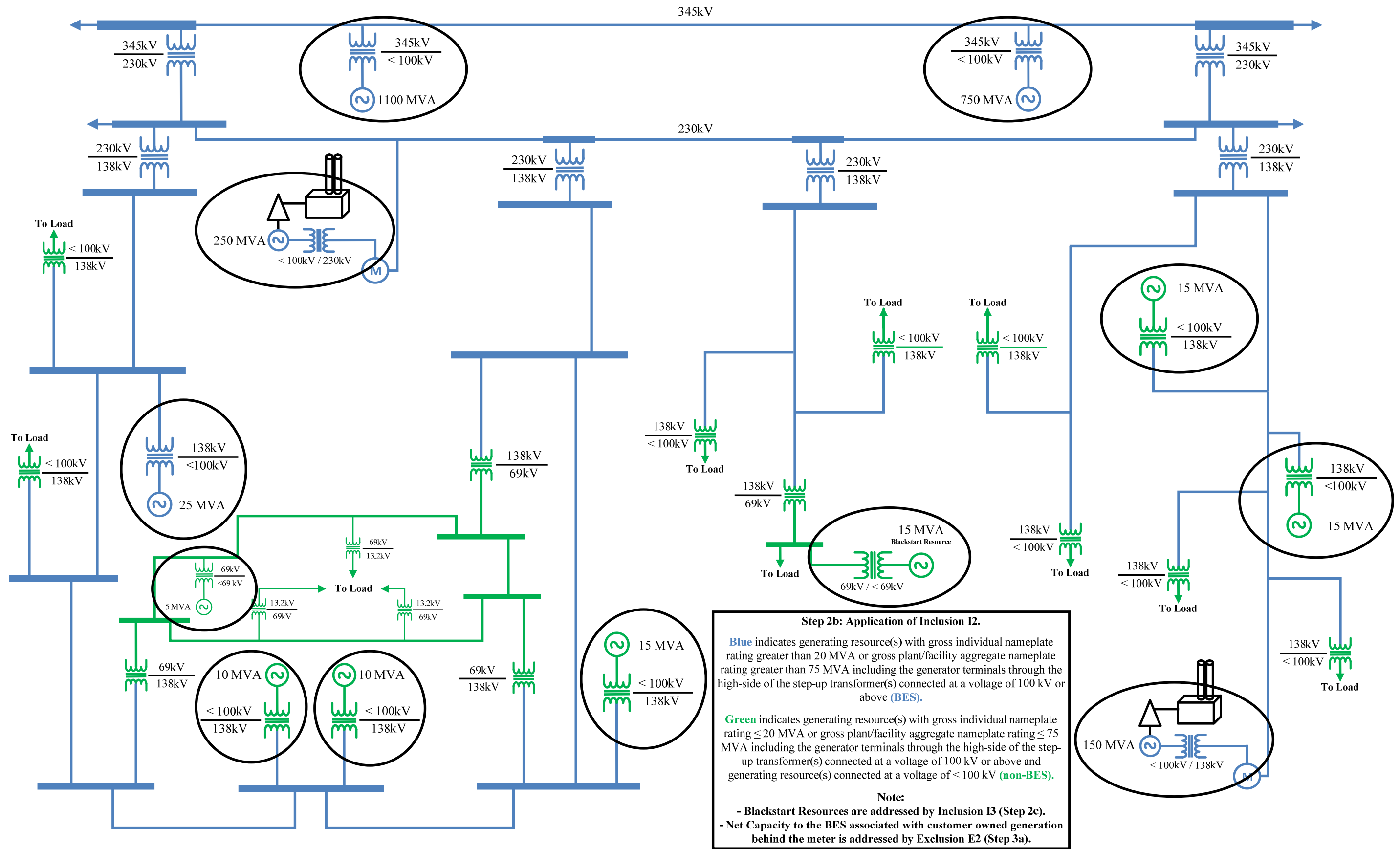

Figure S1-5: System Diagram – Application of Inclusion I2

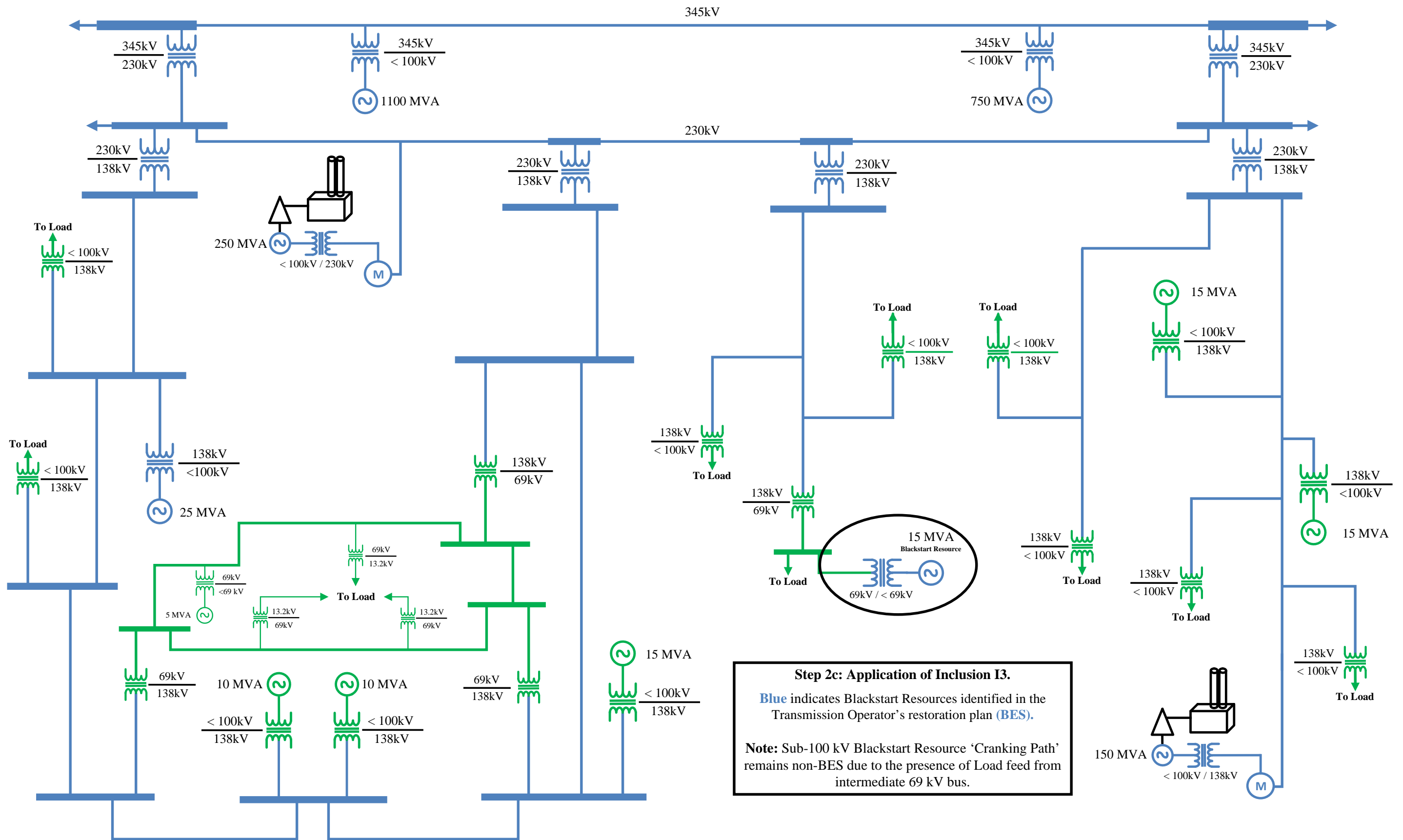

Figure S1-6: System Diagram – Application of Inclusion I3

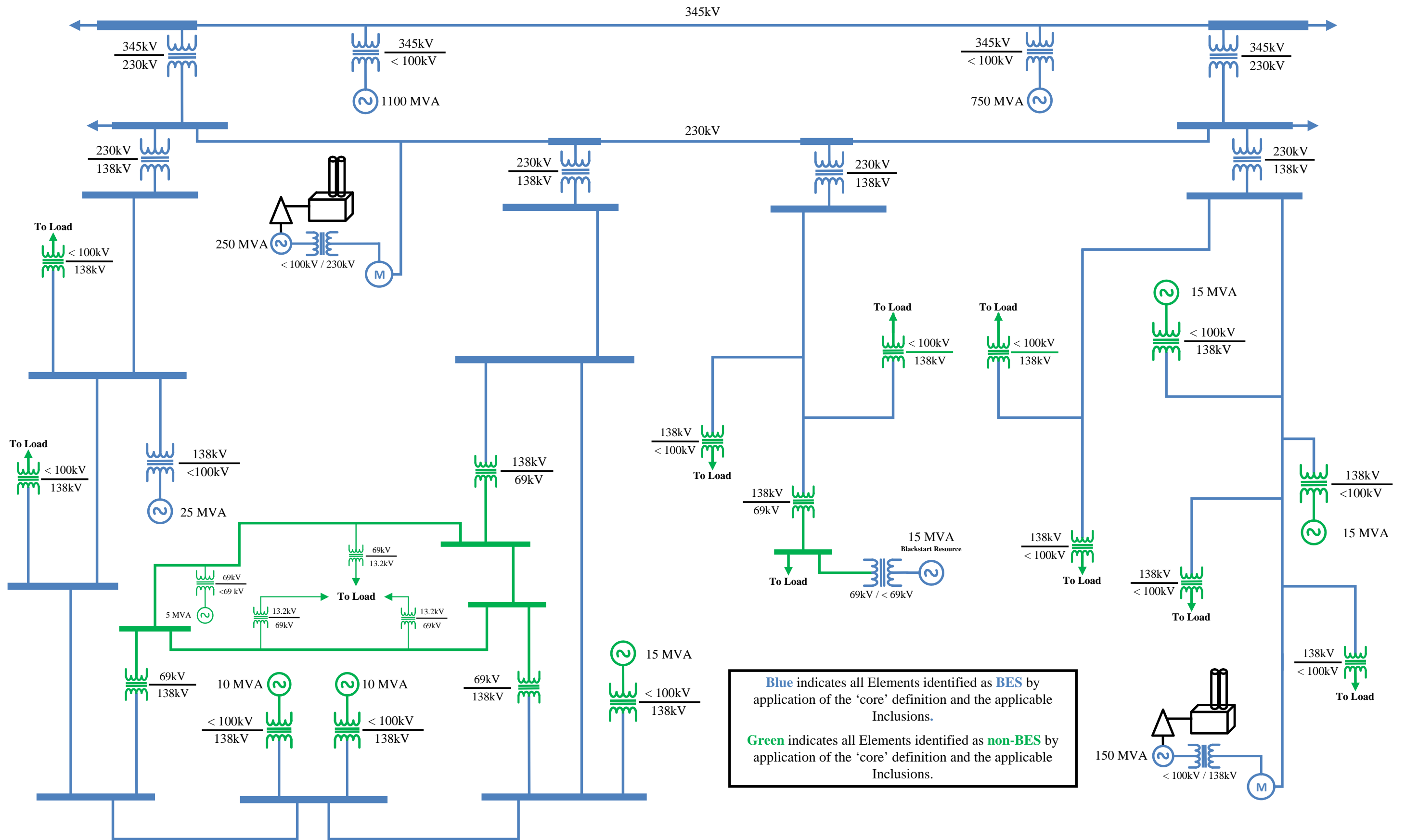

Figure S1-7: System Diagram – Application of 'Core' Definition & Inclusions

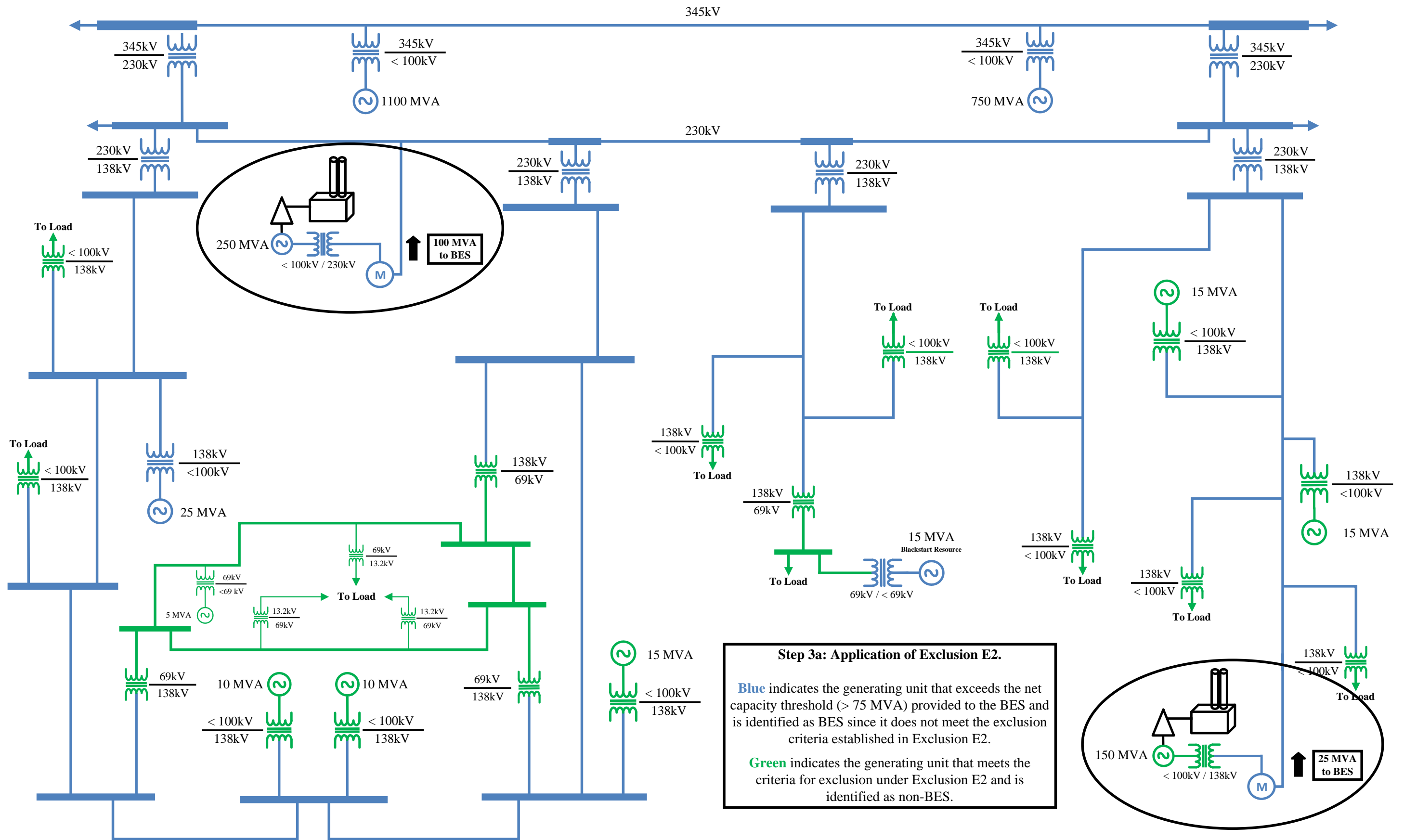

Figure S1-8: System Diagram – Application of Exclusion E2

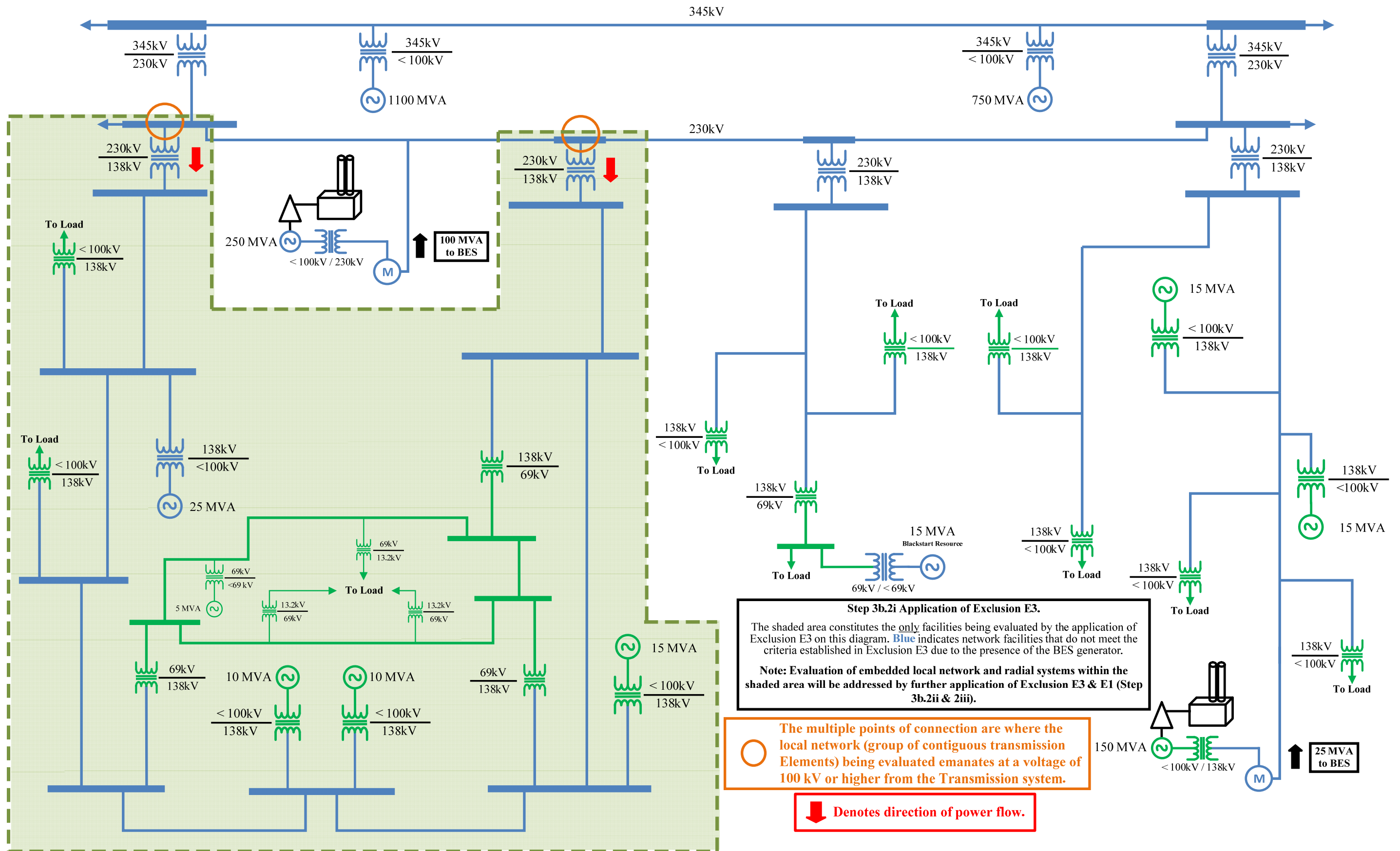

Figure S1-9: System Diagram – Application of Exclusion E3

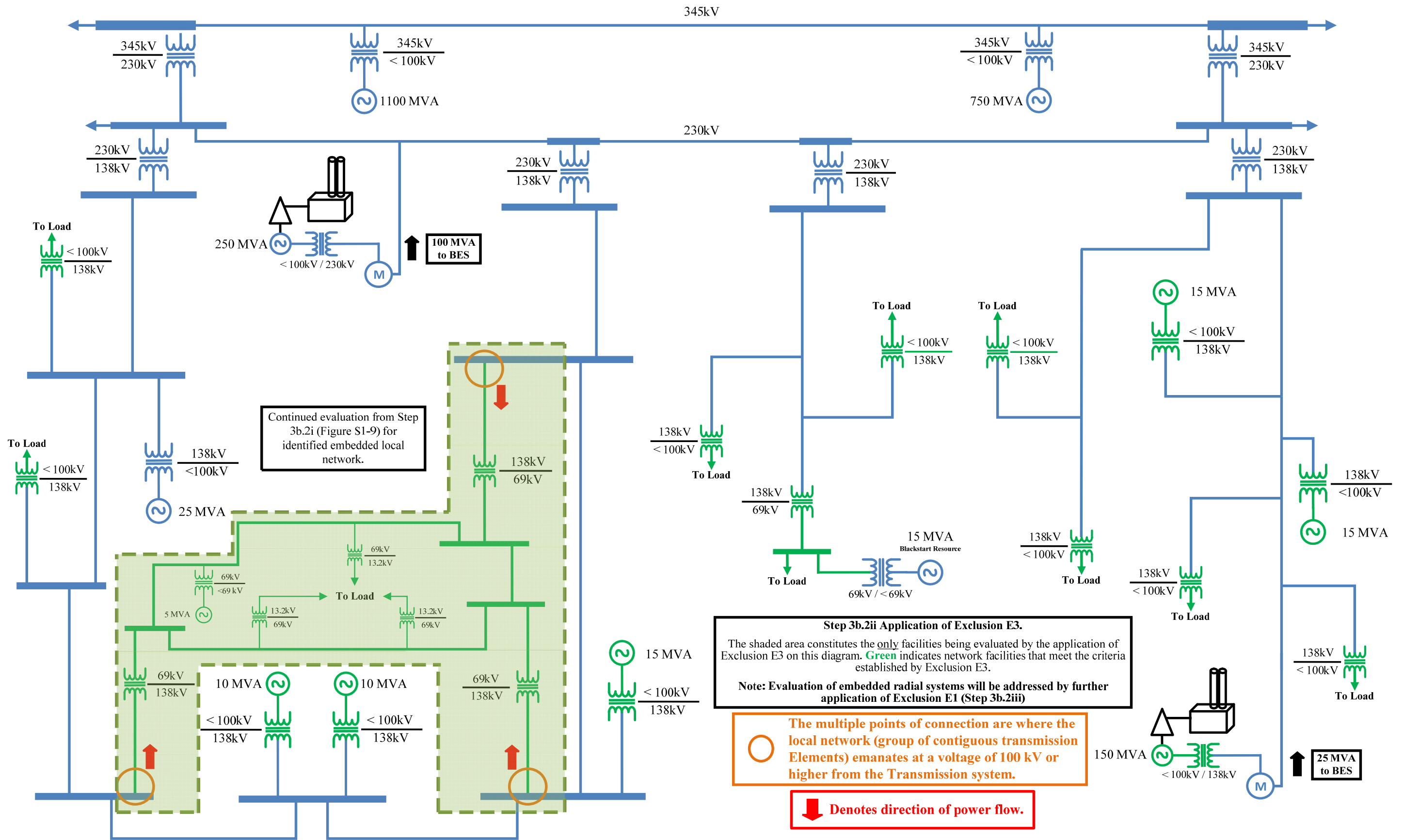

Figure S1-9a: System Diagram – Application of Exclusion E3 (Embedded Local Network)

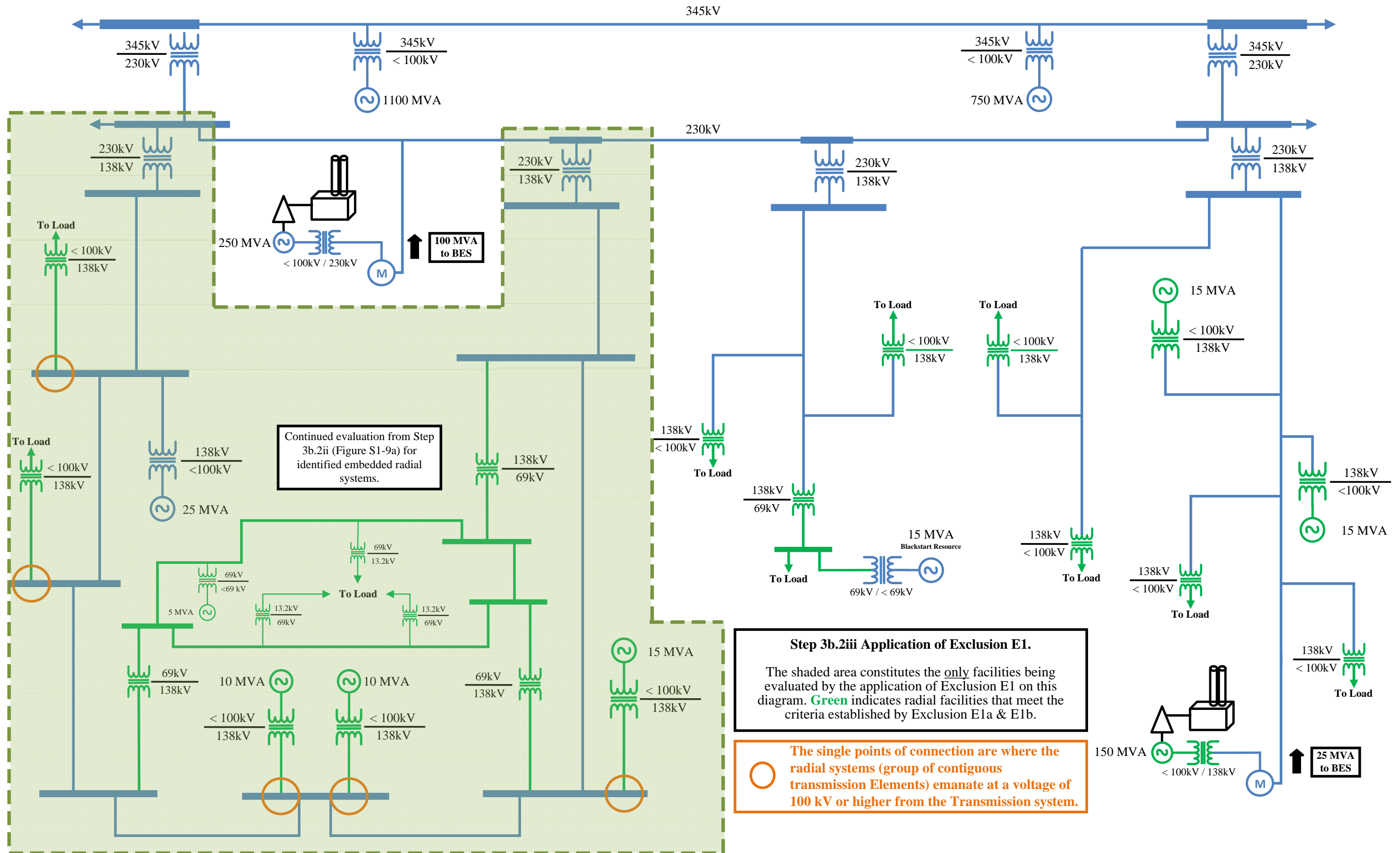

Figure S1-9b: System Diagram – Application of Exclusion E3 (Embedded Radial Systems)

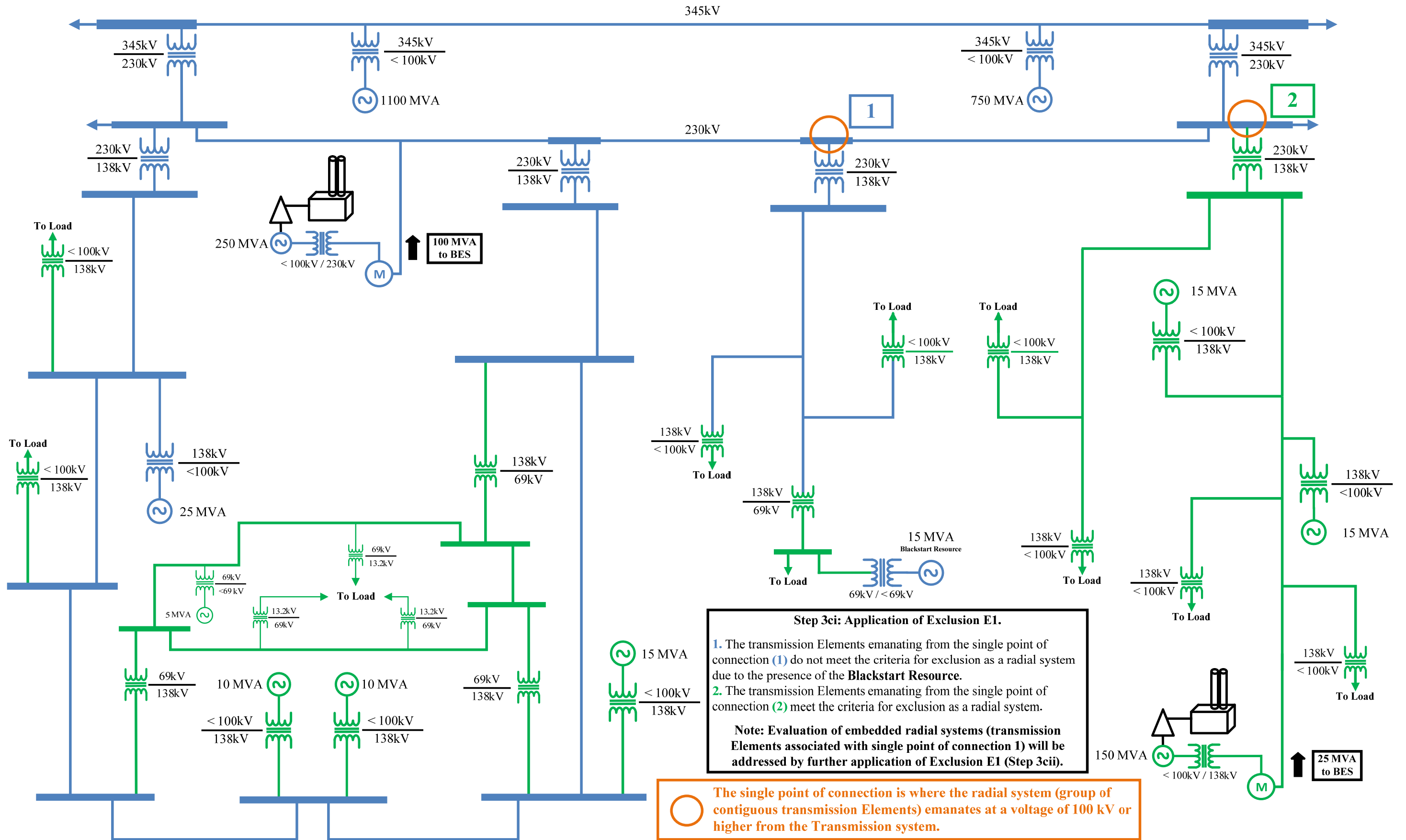

Figure S1-10: System Diagram – Application of Exclusion E1 (Part 1)

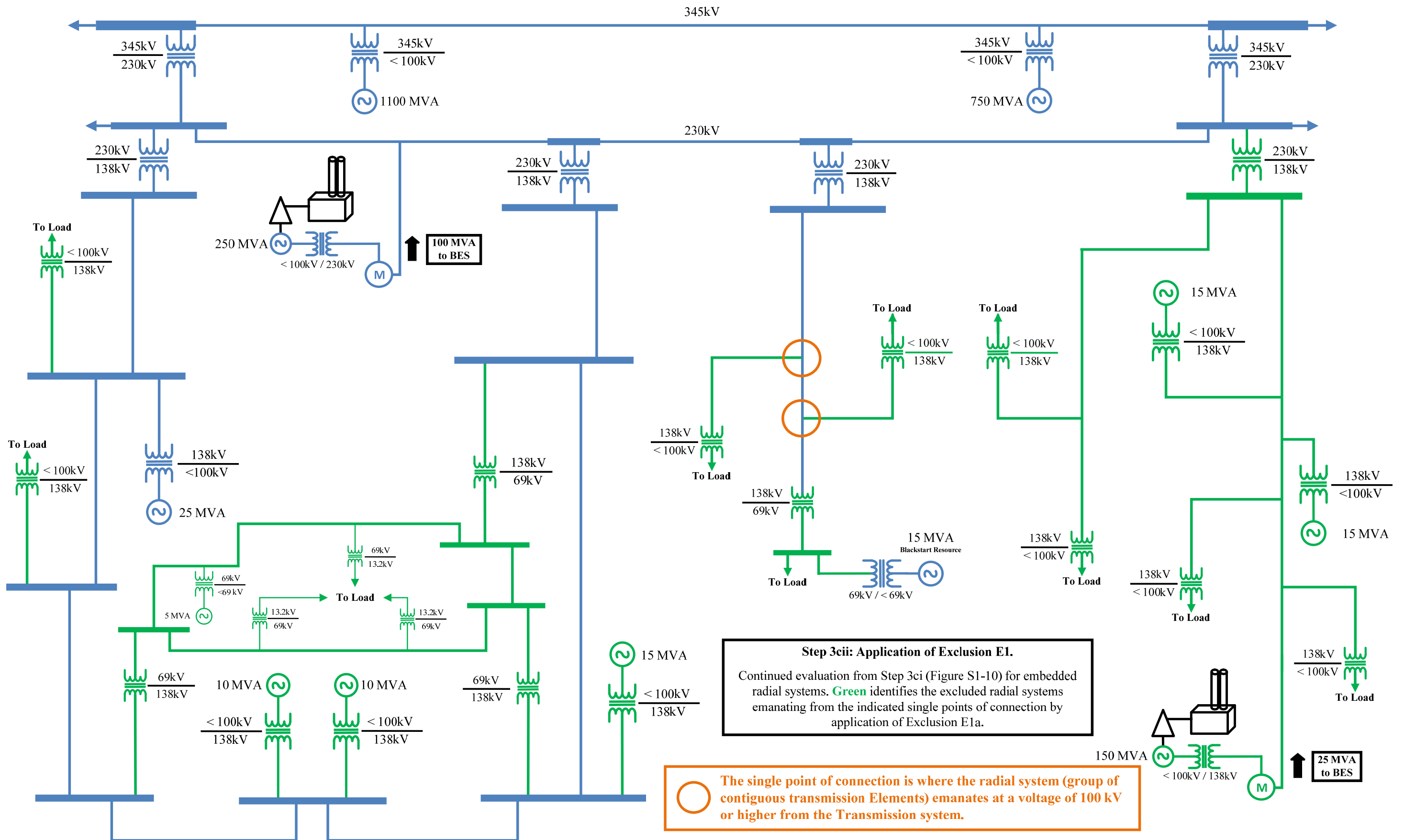

Figure S1-10a: System Diagram – Application of Exclusion E1 (Part 2)

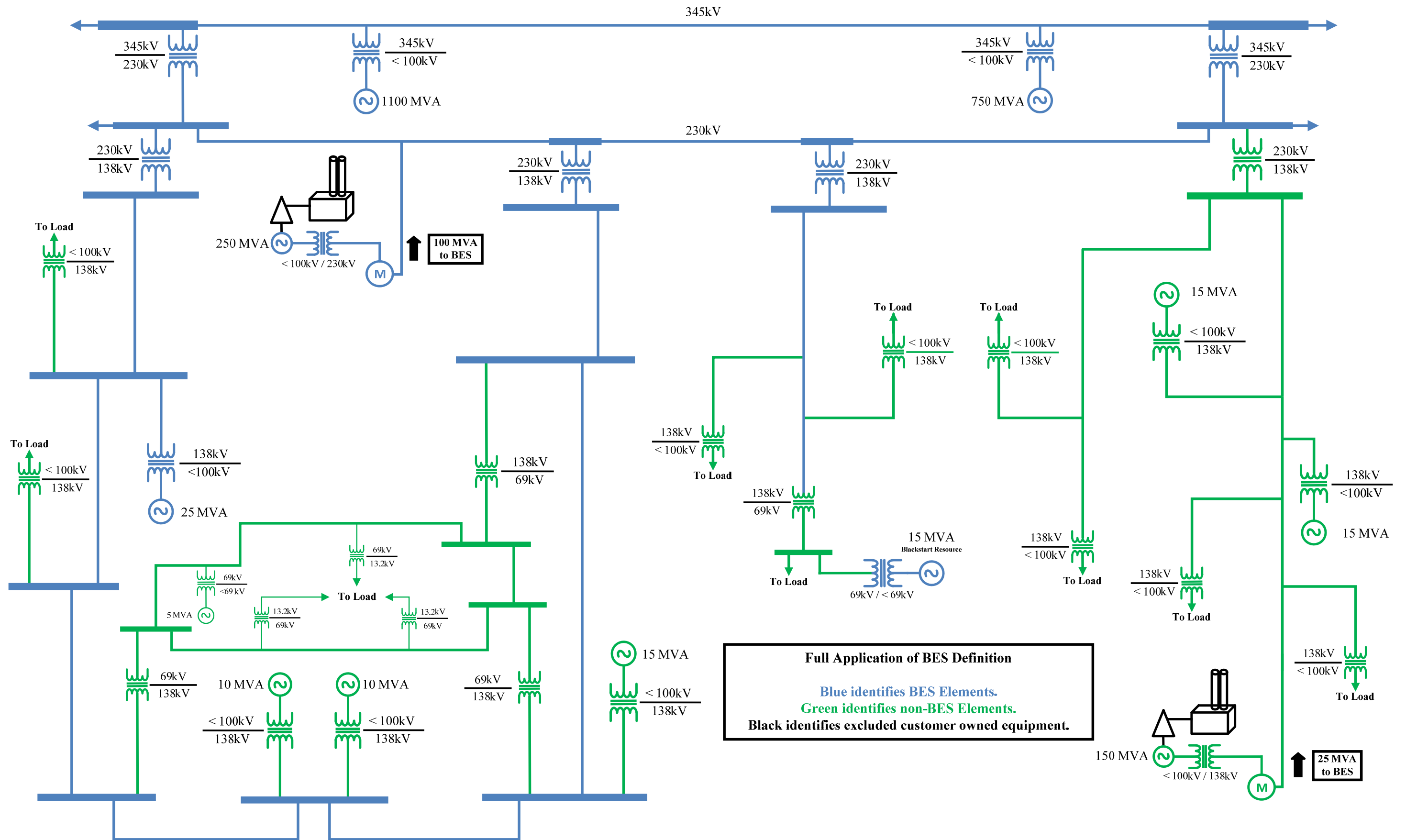

Figure S1-11: System Diagram – Full Application of BES Definition

V. Availability of Exception Process

In the event that the BES definition designates an Element as BES that an entity believes is not necessary for the reliable operation of the interconnected Transmission network or designates an Element as non-BES that an entity believes is necessary for the reliable operation of the interconnected Transmission network, the ERO Rules of Procedure exception process may be utilized on a case-by-case basis to either include or exclude an Element.

The exception process can be found in Section 5C of the ERO Rules of Procedure: “Procedure for Requesting and Receiving an Exception from the Application of the NERC Definition of Bulk Electric System.”

VI. Version History

| Version | Date | Action | Change Tracking |
|---------|------------|--|-----------------|
| 1 | April 2013 | Final Reference Document for Phase 1 BES definition | New |
| 2 | April 2014 | Updated to reflect definition approved by FERC on March 20, 2014 | Revision |
| | | | |
| | | | |
| | | | |
| | | | |
| | | | |
| | | | |
| | | | |
| | | | |
| | | | |
| | | | |
| | | | |
| | | | |