

Technical Rationale

Project 2021-03 CIP-002 | Reliability Standard CIP-002-Y

Control Center Definition and CIP-002-Y– Cyber Security – Bulk Electric System (BES) Cyber System Categorization

Introduction

This document explains the technical rationale and justification for the proposed revisions to the Control Center Definition and Reliability Standard CIP-002-Y. It provides stakeholders and the ERO Enterprise with a description of the technical requirements in the Reliability Standard. These are not Reliability Standards and should not be considered mandatory and enforceable.

Updates to this document include the Project 2021-03 CIP-002 Standards Drafting Team’s (SDT’s) intent in drafting changes to the requirements and definition.

Overview

Project 2021-03 proposes revisions to the Control Center definition and CIP-002-Y Criterion 2.12 in Attachment 1. CIP-002-Y provides “bright-line” criteria for applicable Responsible Entities to categorize their BES Cyber Systems based on the impact to their associated Facilities, systems, and equipment, which, if destroyed, degraded, misused, or otherwise rendered unavailable, would affect the reliable operation of the BES. The proposed revisions to Attachment 1 address the categorization of Transmission Owner Control Centers (TOCCs) performing the functional obligations of a Transmission Operator, specifically those that meet medium impact criteria, and clarifying the language scope of “perform the functional obligations of” throughout the Attachment 1 criteria.

Rationale for Control Center Definition Modifications

Rationale for Proposing Modifications to the Control Center Definition

During the CIP-002 TOCC Field Test¹, it was found that many Transmission Owners struggled with how to interpret the Control Center definition. While the current Control Center definition does not specifically identify Transmission Owners, a Transmission Owner may have a Control Center through its ability to monitor and control the BES in real-time to perform the reliability tasks of a Transmission Operator. This struggle surfaced in the following three manners:

- Lack of a common understanding of the term “control” versus “authority”.
- Lack of a common understanding of the term “perform the functional obligations of the Transmission Operator” as stated in Attachment 1 of CIP-002-5.1a.
- Lack of a common understanding of the term “associated data centers”.

¹ The final field test report is available at https://www.nerc.com/pa/Stand/Project202103_CIP002_Transmission_Owner_Control_Ce/2021-03_CIP-002_TOCC_Field_Test_Final_Report_01262023.pdf.

Modifications to the definition have been proposed to eliminate ambiguity.

Applicable Control Center Entities

The revised Control Center definition is structured to explicitly identify the five different types of registered entities that could have a Control Center.

For Reliability Coordinator, Balancing Authority and Transmission Operator entities, the operating personnel are specifically identified as those individuals who perform Real-time reliability-related tasks. Any rooms that host these operating personnel to monitor and control the BES in real-time are part of the Control Center.

For Transmission Owner and Generator Operator entities, any rooms that host operating personnel having the capability to electronically control Facilities at two or more locations in real-time are part of the Control Center. The term “capability” is specifically used to clarify that a Transmission Owner or Generator Operator that monitors its Facilities without any capability to control those Facilities does not fall within the Control Center definition. Further, the use of the phrase “electronically control” is intended differentiate between an entity who is able to remotely control BES Facilities in real-time (e.g., via a SCADA system) and an entity who is only able to control BES Facilities via field personnel (e.g., via radio or telephone). An entity who is only able to control BES Facilities via field personnel would not fall within the Control Center definition.

When considering the language ‘Facility at two or more locations’, it is generally expected that the Facilities will have separate street addresses. Facilities located at a single street address would be associated with a single location.

Associated Data Centers

The present Control Center definition includes the phrase “associated data centers”. This phrasing was originally intended to ensure the Cyber Assets not co-located in the rooms that host operating personnel are included in the Control Center definition and thus are included in the process of identifying and categorizing BES Cyber Systems.

With the lack of a NERC definition for data center and a wide variety of interpretations, the term “associated data centers” either needed to be defined or needed to be replaced with language that describes the Cyber Assets that need to be included in the Control Center Definition. The phrase “any spaces that house the Cyber Assets used by operating personnel to monitor and control the BES in real-time” was developed to replace “associated data center”.

A space that houses Cyber Assets used by operating personnel to monitor and control the BES in real-time may be:

- located in the same room that houses operating personnel.
- located in a room that does not house operating personnel, but is in the same building as a room that houses operating personnel (shared street address).
- located in a separate building from any rooms that house operating personnel.

- located in a virtual setting.

Cyber Assets used by operating personnel to monitor and control the BES in real-time exclude any RTUs or data aggregation assets used to gather and communicate data to the Control Center. RTUs and data aggregation assets would be evaluated for Cyber Security requirements based on their location and the data that they are gathering.

Rationale for Language to Differentiate Between Control Centers and Other Assets

The preface “Each BES Cyber System, not included in Section 1 above, used by and located at any of the following:” was inserted into Attachment 1 of CIP-002 between Criterion 2.10 and 2.11. This was intentional to make clear that the BES Cyber Systems to consider differ between Control Centers and other assets such as Transmission stations and Generation resources. In alignment with Part 1 of Attachment 1, BES Cyber Systems ‘used by and located at’ Control Centers need to be considered. This prevents expanding from Control Centers down into field assets. With respect to other assets, it is BES Cyber Systems ‘associated with’ the assets that are considered.

Rationale for CIP-002-Y Attachment 1 Criterion 2.12 Modifications

Aggregate Weighted Value

The total aggregate weighted value is used to account for the impact on the BES. The 6,000 aggregate weighted value threshold defined in criterion 2.12 provides sufficient differentiation for medium and low impact BES Cyber Systems associated with Control Centers that are operated by a registered Transmission Operator or owned by a registered Transmission Owner. SDT analysis of data obtained from the CIP-002 Transmission Owner Control Center Field Test² validated that those facilities that may have significant impact are categorized at an appropriate level commensurate with the associated risk.

The total aggregate weighted value of 6,000 was derived based on an entity with no single station or substation that meets criterion 2.5, but who has the capability or authority to control BES Transmission Lines with the equivalent weight of two stations or substations whose BES Cyber Systems would be classified as medium impact per criterion 2.5. This is ultimately derived from the “two or more locations” criteria that is documented in the Control Center definition.

The weight values per line were selected to align with the process that was originally used to establish the weight values per line for criterion 2.5. For BES Transmission Lines 200 kV to 499 kV, the weight values per line of 700 and 1300, respectively, were retained for consistency with criterion 2.5. Similar average MVA line loadings based on kV rating were calculated for BES Transmission Lines less than 100 kV and for BES Transmission Lines 100 kV to 199 kV using Appendix A of NERC’s Severity Risk Index Enhancements Report which result in values of 100 and 250, respectively.

For the purpose of identifying a Responsible Entity’s BES Transmission Lines, a Transmission Line is typically defined by the protection system(s) that would be used to isolate faults on the Transmission Line,

² The final field test report is available at https://www.nerc.com/pa/Stand/Project202103_CIP002_Transmission_Owner_Control_Ce/2021-03_CIP-002_TOCC_Field_Test_Final_Report_01262023.pdf.

which is generally defined by a boundary of fault interrupting devices (e.g., breakers). Transmission Lines can be single-ended, two-ended or three-ended.

In the terms of applicable BES Transmission Lines, the following should be considered:

- All BES Transmission Lines that are energized at voltages less than 100 kV that are monitored and controlled by a Control Center, and that have been specifically designated as part of the BES via the Rules of Procedure Exception Process.
- All BES Transmission Lines that are energized at voltages between 100 kV and 499 kV that are monitored and controlled by a Control Center, including BES Transmission Lines that connect to neighboring entities.
- Multiple-point (or multiple-tap) lines are considered to contribute a single weight value per line. For example, a single 230 kV multiple-point line between three Transmission stations or substations would contribute an aggregate weighted value of 700 and connect Transmission Facilities at a single station or substation to two other Transmission stations or substations.
- Multiple lines between two Transmission stations or substations are considered to contribute multiple weight values per line, but these multiple lines between the two stations only connect one station to one other station. For example, two 345 kV lines between two Transmission stations or substations would contribute an aggregate weighted value of 2,600 and connect Transmission Facilities at a single station or substation to one other Transmission station or substation.

BES Transmission Lines that are energized at voltages of 500 kV and above have no contribution to the aggregated weighted value given that criterion 2.4 already includes BES Cyber Systems for any Transmission Facilities at substations that are operated at 500 kV or higher as medium impact. Further, criterion 1.3 includes the BES Cyber Systems used by and located at Control Centers or backup Control Centers that monitor and control any BES Transmission Lines at substations that are operated at 500 kV or higher as high impact.

Exclusion Clause

The exclusion clause applies to Transmission Operators and Transmission Owners operated at less than 300 kV, where the net export from the local system does not exceed 75 MW during non-Energy Emergency Alert (EEA) conditions. The purpose of the exclusion clause is to allow for a Responsible Entity to exclude BES Transmission Lines within a local system from the “aggregate weighted value” calculation if the net export does not exceed 75 MW during non-EEA conditions. This allows for categorization at an appropriate level commensurate with the associated risk for local systems that are primarily designed to serve load, and that do not have a reliability impact on the BES. The bright line of 75 MW was selected to align with pre-existing criteria including (1) the registration criteria for a Distribution Provider and (2) the registration criteria for a Generator Owner.

EEA conditions were specifically excluded to ensure a Responsible Entity is not disincentivized from providing all available assistance during emergency conditions due to future compliance considerations.

Example 1

In example 1 below, BES Cyber System(s) are associated with a Control Center that monitors and controls eight BES Transmission Lines. In order to calculate the Control Center’s aggregate weighted value, the Responsible Entity should reference the table located in Criterion 2.12 and sum the weighted values for each BES Transmission Line.

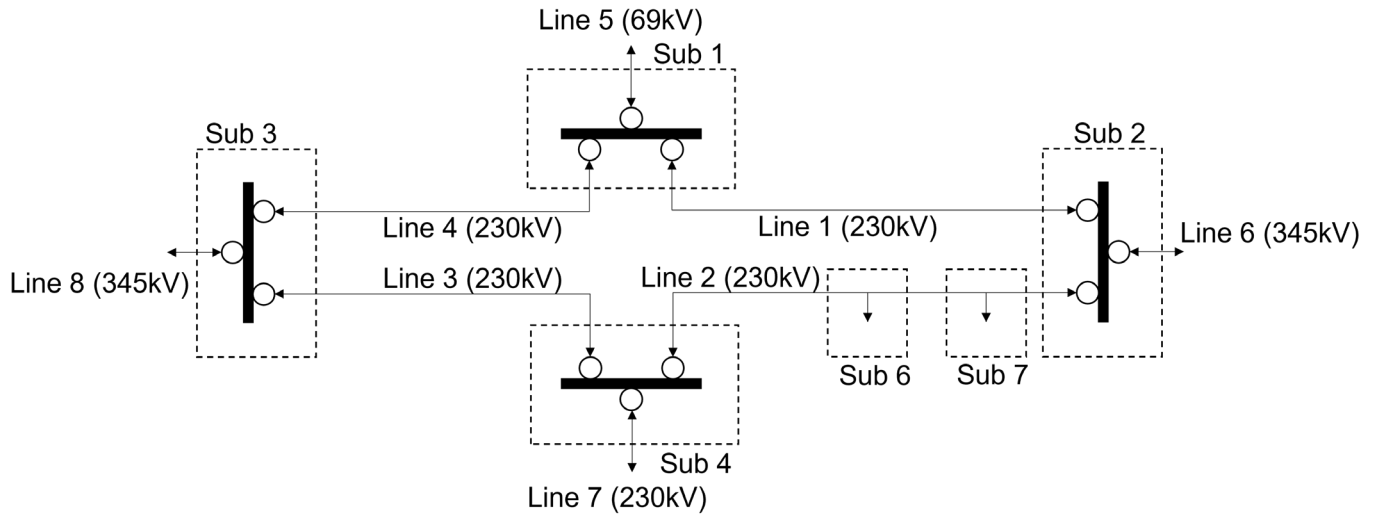

Note: Substation equipment (e.g., transformers) is not shown for simplicity. Circles represent fault interrupting devices.

The weighted value for each BES Transmission Line is detailed in the following table by voltage classification. The calculation of the weighted values is demonstrated below and equates to an aggregate weighted value of 6,100, which is above the minimum threshold for the medium impact rating required in Criterion 2.12. In accordance with Criterion 2.12, the BES Cyber System(s) associated with the Control Center should be categorized as medium impact BES Cyber System(s).

The circles on the diagram indicate the presence of fault interrupting devices. There are two substations shown (Sub 6, and Sub 7) that are tapped on Line 2 for load serving purposes; however, these substations do not have fault interrupting devices that will operate for a fault on Line 2. Therefore, the BES Transmission Line is defined between Sub 2 and Sub 4.

Voltage Value of a Line	Weight Value per Line	Applicable Lines	Weighted Value
< 100 kV	100	None	0
100 kV to 199 kV	250	None	0
200 kV to 299 kV	700	Line 1, Line 2, Line 3, Line 4, Line 7	3500
300 kV to 499 kV	1300	Line 6, Line 8	2600
500 kV and above	0	None	0

* Line five is less than 100 kV; however, no exception has been obtained through the NERC Rules of Procedure Exception Process and therefore, the line is not BES.

Calculation

$$700+700+700+700+700+1300+1300 = 6100$$

Example 2

In example 2 below, BES Cyber System(s) are associated with a Control Center that monitors and controls eight BES Transmission Lines. In order to calculate the Control Center’s aggregate weighted value, the Responsible Entity should reference the table located in Criterion 2.12 and sum the weighted values for each BES Transmission Line.

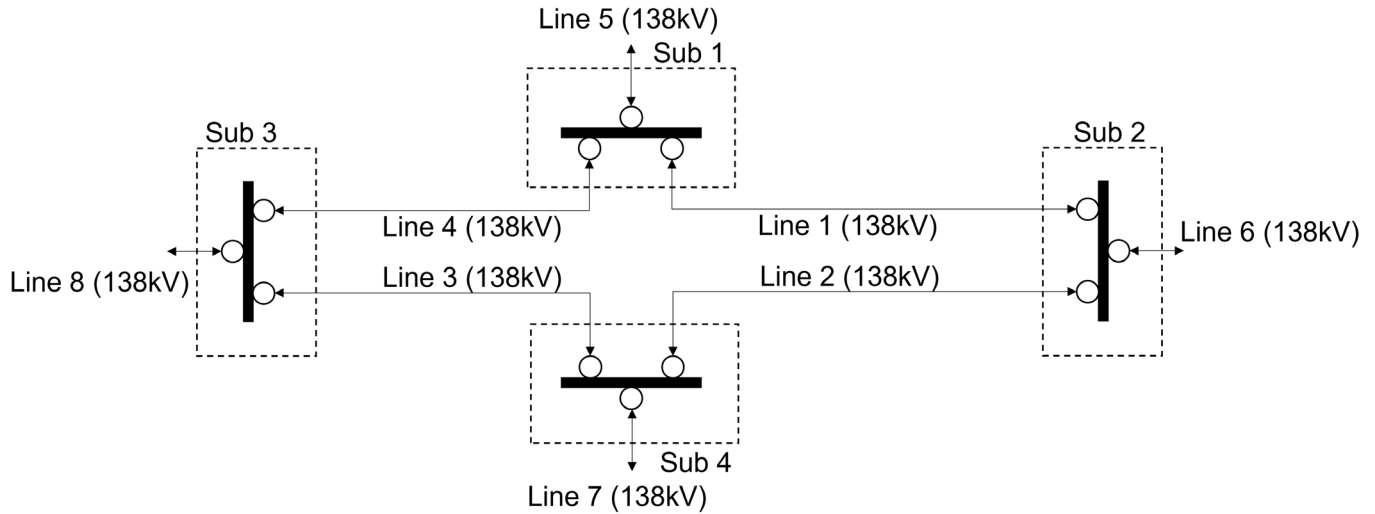

Note: Substation equipment (e.g., transformers) is not shown for simplicity. Circles represent fault interrupting devices.

The weighted value for each BES Transmission Line is detailed in the following table by voltage classification. The calculation of the weighted values is demonstrated below and equates to an aggregate weighted value of 2,000, which is below the minimum threshold for the medium impact rating required in Criterion 2.12. The BES Cyber System(s) associated with the Control Center in this example should be categorized as low impact BES Cyber System(s) pursuant to Criterion 3.1.

Voltage Value of a Line	Weight Value per Line	Applicable Lines	Weighted Value
< 100 kV	100	None	0
100 kV to 199 kV	250	Line 1, Line 2, Line 3, Line 4, Line 5, Line 6 Line 7, Line 8	2000
200 kV to 299 kV	700	None	0
300 kV to 499 kV	1300	None	0
500 kV and above	0	None	0

Calculation

$$250+250+250+250+250+250+250+250 = 2000$$

Example 3

In example 3 below, BES Cyber System(s) are associated with a Control Center that monitors and controls five BES Transmission Lines that have not been excluded from the calculation. In order to calculate the Control Center’s aggregate weighted value, the Responsible Entity should reference the table located in Criterion 2.12, and the exclusion language, and sum the weighted values for each BES Transmission Line that has been defined by the Responsible Entity and that does not meet the exclusion clause.

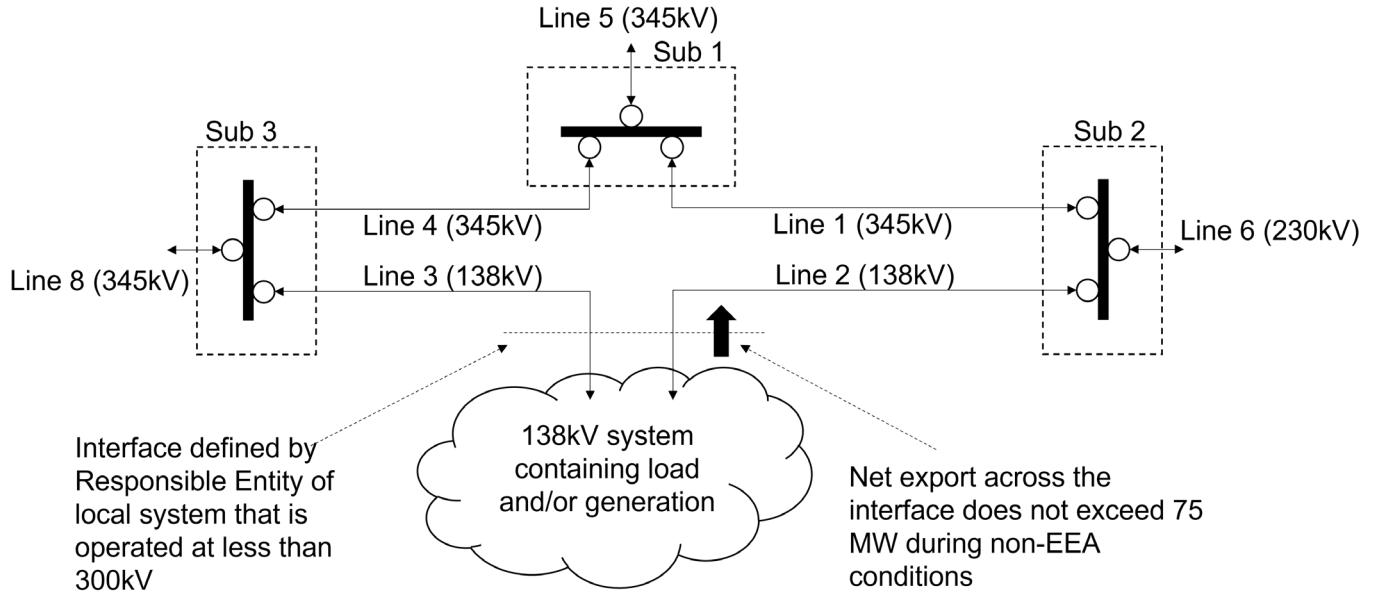

Note: Substation equipment (e.g., transformers) is not shown for simplicity. Circles represent fault interrupting devices.

The weighted value for each BES Transmission Line is detailed in the following table by voltage classification. The calculation of the weighted values is demonstrated below and equates to an aggregate weighted value of 5,900, which is below the minimum threshold for the medium impact rating required in Criterion 2.12. The BES Cyber System(s) associated with the Control Center in this example should be categorized as low impact BES Cyber System(s) pursuant to Criterion 3.1.

Voltage Value of a Line	Weight Value per Line	Applicable Lines	Weighted Value
< 100 kV	100	None	0
100 kV to 199 kV	250	None	0
200 kV to 299 kV	700	Line 6	700
300 kV to 499 kV	1300	Line 1, Line 4, Line 5, Line 8	5200
500 kV and above	0	None	0

* Lines 2 and 3 (along with any additional lines located in the 138kV local system) are excluded from the calculation because the Responsible Entity has defined an interface to a local system that is operated at

less than 300kV, where the net export across the interface does not exceed 75 MW during non-Energy Emergency Alert (EEA) conditions.

Calculation

$$700+1300+1300+1300+1300 = 5900$$

Former Background Section from Reliability Standard CIP-002-5.1a

The Background section has been retired and removed from the standard and preserved by cutting and pasting as-is below.

Background

This standard provides “bright-line” criteria for applicable Responsible Entities to categorize their BES Cyber Systems based on the impact of their associated Facilities, systems, and equipment, which, if destroyed, degraded, misused, or otherwise rendered unavailable, would affect the reliable operation of the Bulk Electric System. Several concepts provide the basis for the approach to the standard.

Throughout the standards, unless otherwise stated, bulleted items in the requirements are items that are linked with an “or,” and numbered items are items that are linked with an “and.”

Many references in the Applicability section and the criteria in Attachment 1 of CIP-002 use a threshold of 300 MW for UFLS and UVLS. This particular threshold of 300 MW for UVLS and UFLS was provided in Version 1 of the CIP Cyber Security Standards. The threshold remains at 300 MW since it is specifically addressing UVLS and UFLS, which are last ditch efforts to save the Bulk Electric System. A review of UFLS tolerances defined within regional reliability standards for UFLS program requirements to date indicates that the historical value of 300 MW represents an adequate and reasonable threshold value for allowable UFLS operational tolerances.

BES Cyber Systems

One of the fundamental differences between Versions 4 and 5 of the CIP Cyber Security Standards is the shift from identifying Critical Cyber Assets to identifying BES Cyber Systems. This change results from the drafting team’s review of the NIST Risk Management Framework and the use of an analogous term “information system” as the target for categorizing and applying security controls.

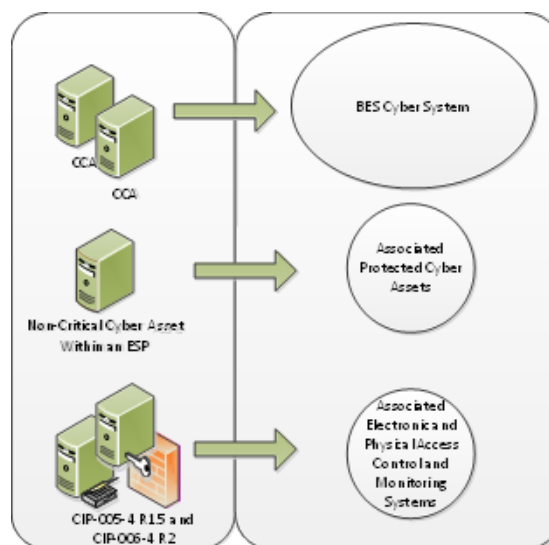

In transitioning from Version 4 to Version 5, a BES Cyber System can be viewed simply as a grouping of Critical Cyber Assets (as that term is used in Version 4). The CIP Cyber Security Standards use the “BES Cyber System” term primarily to provide a higher level for referencing the object of a requirement. For example, it becomes possible to apply requirements dealing with recovery and malware protection to a grouping rather than individual Cyber Assets, and it becomes clearer in the requirement that malware protection applies to the system as a whole and may not be necessary for every individual device to comply.

Another reason for using the term “BES Cyber System” is to provide a convenient level at which a Responsible Entity can organize their documented implementation of the requirements and compliance evidence. Responsible Entities can use the well-developed concept of a *security plan* for each BES Cyber System to document the programs, processes, and plans in place to comply with security requirements.

It is left up to the Responsible Entity to determine the level of granularity at which to identify a BES Cyber System within the qualifications in the definition of BES Cyber System. For example, the Responsible Entity might choose to view an entire plant control system as a single BES Cyber System, or it might choose to view certain components of the plant control system as distinct BES Cyber Systems. The Responsible Entity should take into consideration the operational environment and scope of management when defining the BES Cyber System boundary in order to maximize efficiency in secure operations. Defining the boundary too tightly may result in redundant paperwork and authorizations, while defining the boundary too broadly could make the secure operation of the BES Cyber System difficult to monitor and assess.

Reliable Operation of the BES

The scope of the CIP Cyber Security Standards is restricted to BES Cyber Systems that would impact the reliable operation of the BES. In order to identify BES Cyber Systems, Responsible Entities determine whether the BES Cyber Systems perform or support any BES reliability function according to those reliability tasks identified for their reliability function and the corresponding functional entity’s responsibilities as defined in its relationships with other functional entities in the NERC Functional Model. This ensures that the *initial* scope for consideration includes only those BES Cyber Systems and their associated BES Cyber Assets that perform or support the reliable operation of the BES. The definition of BES Cyber Asset provides the basis for this scoping.

Real-time Operations

One characteristic of the BES Cyber Asset is a real-time scoping characteristic. The time horizon that is significant for BES Cyber Systems and BES Cyber Assets subject to the application of these Version 5 CIP Cyber Security Standards is defined as that which is material to real-time operations for the reliable operation of the BES. To provide a better defined time horizon than “Real-time,” BES Cyber Assets are those Cyber Assets that, if rendered unavailable, degraded, or misused, would adversely impact the reliable operation of the BES within 15 minutes of the activation or exercise of the compromise. This time window must not include in its consideration the activation of redundant BES Cyber Assets or BES Cyber Systems: from the cyber security standpoint, redundancy does not mitigate cyber security vulnerabilities.

Categorization Criteria

The criteria defined in Attachment 1 are used to categorize BES Cyber Systems into impact categories. Requirement 1 only requires the discrete identification of BES Cyber Systems for those in the high impact and medium impact categories. All BES Cyber Systems for Facilities not included in Attachment 1 – Impact Rating Criteria, Criteria 1.1 to 1.4 and Criteria 2.1 to 2.11 default to be low impact.

This general process of categorization of BES Cyber Systems based on impact on the reliable operation of the BES is consistent with risk management approaches for the purpose of application of cyber security requirements in the remainder of the Version 5 CIP Cyber Security Standards.

Electronic Access Control or Monitoring Systems, Physical Access Control Systems, and Protected Cyber Assets that are associated with BES Cyber Systems

BES Cyber Systems have associated Cyber Assets, which, if compromised, pose a threat to the BES Cyber System by virtue of: (a) their location within the Electronic Security Perimeter (Protected Cyber Assets), or (b) the security control function they perform (Electronic Access Control or Monitoring Systems and Physical Access Control Systems). These Cyber Assets include:

Electronic Access Control or Monitoring Systems (“EACMS”)

Examples include: Electronic Access Points, Intermediate Systems, authentication servers (e.g., RADIUS servers, Active Directory servers, Certificate Authorities), security event monitoring systems, and intrusion detection systems.

Physical Access Control Systems (“PACS”)

Examples include: authentication servers, card systems, and badge control systems.

Protected Cyber Assets (“PCA”)

Examples may include, to the extent they are within the ESP: file servers, ftp servers, time servers, LAN switches, networked printers, digital fault recorders, and emission monitoring systems.

Technical Rationale for Reliability Standard CIP-002-5.1a

This section contains a “cut and paste” of the former Guidelines and Technical Basis (GTB) as-is of from the CIP-002-5.1a standard to preserve any historical references. No modifications have been made.

Guidelines and Technical Basis

Section 4 – Scope of Applicability of the CIP Cyber Security Standards

Section “4. Applicability” of the standards provides important information for Responsible Entities to determine the scope of the applicability of the CIP Cyber Security Requirements.

Section “4.1. Functional Entities” is a list of NERC functional entities to which the standard applies. If the entity is registered as one or more of the functional entities listed in section 4.1, then the NERC CIP Cyber Security Standards apply. Note that there is a qualification in section 4.1 that restricts the applicability in the case of Distribution Providers to only those that own certain types of systems and equipment listed in 4.2.

Section “4.2. Facilities” defines the scope of the Facilities, systems, and equipment owned by the Responsible Entity, as qualified in section 4.1, that is subject to the requirements of the standard. In addition to the set of BES Facilities, Control Centers, and other systems and equipment, the list includes the qualified set of systems and equipment owned by Distribution Providers. While the NERC Glossary term “Facilities” already includes the BES characteristic, the additional use of the term BES here is meant to reinforce the scope of applicability of these Facilities where it is used, especially in this applicability scoping section. This in effect sets the scope of Facilities, systems, and equipment that is subject to the standards. This section is especially significant in CIP-002-5.1a and represents the total scope of Facilities, systems, and equipment to which the criteria in Attachment 1 apply. This is important because it determines the balance of these Facilities, systems, and equipment that are Low Impact once those that qualify under the High and Medium Impact categories are filtered out.

For the purpose of identifying groups of Facilities, systems, and equipment, whether by location or otherwise, the Responsible Entity identifies assets as described in Requirement R1 of CIP-002-5.1a. This is a process familiar to Responsible Entities that have to comply with versions 1, 2, 3, and 4 of the CIP standards for Critical Assets. As in versions 1, 2, 3, and 4, Responsible Entities may use substations, generation plants, and Control Centers at single site locations as identifiers of these groups of Facilities, systems, and equipment.

CIP-002 -5 .1a

CIP-002-5.1a requires that applicable Responsible Entities categorize their BES Cyber Systems and associated BES Cyber Assets according to the criteria in Attachment 1. A BES Cyber Asset includes in its definition, “...that if rendered unavailable, degraded, or misused would, within 15 minutes adversely impact the reliable operation of the BES.”

The following provides guidance that a Responsible Entity may use to identify the BES Cyber Systems that would be in scope. The concept of BES reliability operating service is useful in providing Responsible Entities with the option of a defined process for scoping those BES Cyber Systems that would be subject

to CIP-002-5.1a. The concept includes a number of named BES reliability operating services. These named services include:

- Dynamic Response to BES conditions
- Balancing Load and Generation
- Controlling Frequency (Real Power)
- Controlling Voltage (Reactive Power)
- Managing Constraints
- Monitor & Control
- Restoration of BES
- Situational Awareness
- Inter-Entity Real-Time Coordination and Communication

Responsibility for the reliable operation of the BES is spread across all Entity Registrations. Each entity registration has its own special contribution to reliable operations and the following discussion helps identify which entity registration, in the context of those functional entities to which these CIP standards apply, performs which reliability operating service, as a process to identify BES Cyber Systems that would be in scope. The following provides guidance for Responsible Entities to determine applicable reliability operations services according to their Function Registration type.

Entity Registration	RC	BA	TOP	TO	DP	GOP	GO
Dynamic Response		X	X	X	X	X	X
Balancing Load & Generation	X	X	X	X	X	X	X
Controlling Frequency		X				X	X
Controlling Voltage			X	X	X		X
Managing Constraints	X		X			X	
Monitoring and Control			X			X	
Restoration			X			X	
Situation Awareness	X	X	X			X	
Inter-Entity coordination	X	X	X	X		X	X

Dynamic Response

The Dynamic Response Operating Service includes those actions performed by BES Elements or subsystems which are automatically triggered to initiate a response to a BES condition. These actions are triggered by a single element or control device or a combination of these elements or devices in concert to perform an action or cause a condition in reaction to the triggering action or condition. The types of dynamic responses that may be considered as potentially having an impact on the BES are:

- Spinning reserves (contingency reserves)
 - Providing actual reserve generation when called upon (GO,GOP)
 - Monitoring that reserves are sufficient (BA)
- Governor Response
 - Control system used to actuate governor response (GO)
 - Protection Systems (transmission & generation)
 - Lines, buses, transformers, generators (DP, TO, TOP, GO, GOP)
 - Zone protection for breaker failure (DP, TO, TOP)
 - Breaker protection (DP, TO, TOP)
 - Current, frequency, speed, phase (TO, TOP, GO, GOP)
 - Special Protection Systems or Remedial Action Schemes
 - Sensors, relays, and breakers, possibly software (DP, TO, TOP)
 - Under and Over Frequency relay protection (includes automatic load shedding)
 - Sensors, relays & breakers (DP)
 - Under and Over Voltage relay protection (includes automatic load shedding)
 - Sensors, relays & breakers (DP)
 - Power System Stabilizers (GO)

Balancing Load and Generation

The Balancing Load and Generation Operations Service includes activities, actions and conditions necessary for monitoring and controlling generation and load in the operations planning horizon and in real-time. Aspects of the Balancing Load and Generation function include, but are not limited to:

- Calculation of Area Control Error (ACE)
 - Field data sources (real time tie flows, frequency sources, time error, etc.) (TO, TOP)
 - Software used to perform calculation (BA)
- Demand Response
 - Ability to identify load change need (BA)
 - Ability to implement load changes (TOP, DP)

- Manually Initiated Load shedding
 - Ability to identify load change need (BA)
 - Ability to implement load changes (TOP, DP)
- Non-spinning reserve (contingency reserve)
 - Know generation status, capability, ramp rate, start time (GO, BA)
 - Start units and provide energy (GOP)

Controlling Frequency (Real Power)

The Controlling Frequency Operations Service includes activities, actions and conditions which ensure, in real time, that frequency remains within bounds acceptable for the reliability or operability of the BES. Aspects of the Controlling Frequency function include, but are limited to:

- Generation Control (such as AGC)
 - ACE, current generator output, ramp rate, unit characteristics (BA, GOP, GO)
 - Software to calculate unit adjustments (BA)
 - Transmit adjustments to individual units (GOP)
 - Unit controls implementing adjustments (GOP)
- Regulation (regulating reserves)
 - Frequency source, schedule (BA)
 - Governor control system (GO)

Controlling Voltage (Reactive Power)

The Controlling Voltage Operations Service includes activities, actions and conditions which ensure, in real time, that voltage remains within bounds acceptable for the reliability or operability of the BES. Aspects of the Controlling Voltage function include, but are not limited to:

- Automatic Voltage Regulation (AVR)
 - Sensors, stator control system, feedback (GO)
- Capacitive resources
 - Status, control (manual or auto), feedback (TOP, TO,DP)
- Inductive resources (transformer tap changer, or inductors)
 - Status, control (manual or auto), feedback (TOP,TO,DP)
- Static VAR Compensators (SVC)
 - Status, computations, control (manual or auto), feedback (TOP, TO,DP)

Managing Constraints

Managing Constraints includes activities, actions and conditions that are necessary to ensure that elements of the BES operate within design limits and constraints established for the reliability and operability of the BES. Aspects of the Managing Constraints include, but are not limited to:

- Available Transfer Capability (ATC) (TOP)
- Interchange schedules (TOP, RC)
- Generation re-dispatch and unit commit (GOP)
- Identify and monitor SOL's & IROL's (TOP, RC)
- Identify and monitor Flow gates (TOP, RC)

Monitoring and Control

Monitoring and Control includes those activities, actions and conditions that provide monitoring and control of BES Elements. An example aspect of the Control and Operation function is:

- All methods of operating breakers and switches
 - SCADA (TOP, GOP)
 - Substation automation (TOP)

Restoration of BES

The Restoration of BES Operations Service includes activities, actions and conditions necessary to go from a shutdown condition to an operating condition delivering electric power without external assistance. Aspects of the Restoration of BES function include, but are not limited to:

- Restoration including planned cranking path
 - Through black start units (TOP, GOP)
 - Through tie lines (TOP, GOP)
- Off-site power for nuclear facilities. (TOP, TO, BA, RC, DP, GO, GOP)
- Coordination (TOP, TO, BA, RC, DP, GO, GOP)

Situational Awareness

The Situational Awareness function includes activities, actions and conditions established by policy, directive or standard operating procedure necessary to assess the current condition of the BES and anticipate effects of planned and unplanned changes to conditions. Aspects of the Situation Awareness function include:

- Monitoring and alerting (such as EMS alarms) (TOP, GOP, RC,BA)
- Change management (TOP,GOP,RC,BA)
- Current Day and Next Day planning (TOP)
- Contingency Analysis (RC)

- Frequency monitoring (BA, RC)

Inter-Entity Coordination

The Inter-Entity coordination and communication function includes activities, actions, and conditions established by policy, directive, or standard operating procedure necessary for the coordination and communication between Responsible Entities to ensure the reliability and operability of the BES. Aspects of the Inter-Entity Coordination and Communication function include:

- Scheduled interchange (BA, TOP, GOP, RC)
- Facility operational data and status (TO, TOP, GO, GOP, RC, BA)
- Operational directives (TOP, RC, BA)

Applicability to Distribution Providers

It is expected that only Distribution Providers that own or operate facilities that qualify in the Applicability section will be subject to these Version 5 Cyber Security Standards. Distribution Providers that do not own or operate any facility that qualifies are not subject to these standards. The qualifications are based on the requirements for registration as a Distribution Provider and on the requirements applicable to Distribution Providers in NERC Standard EOP-005.

Requirement R1:

Requirement R1 implements the methodology for the categorization of BES Cyber Systems according to their impact on the BES. Using the traditional risk assessment equation, it reduces the measure of the risk to an impact (consequence) assessment, assuming the vulnerability index of 1 (the Systems are assumed to be vulnerable) and a probability of threat of 1 (100 percent). The criteria in Attachment 1 provide a measure of the impact of the BES assets supported by these BES Cyber Systems.

Responsible Entities are required to identify and categorize those BES Cyber Systems that have high and medium impact. BES Cyber Systems for BES assets not specified in Attachment 1, Criteria 1.1 – 1.4 and Criteria 2.1 – 2.11 default to low impact.

Attachment 1

Overall Application

In the application of the criteria in Attachment 1, Responsible Entities should note that the approach used is based on the impact of the BES Cyber System as measured by the bright-line criteria defined in Attachment 1.

- When the drafting team uses the term “Facilities”, there is some latitude to Responsible Entities to determine included Facilities. The term Facility is defined in the NERC Glossary of Terms as “A set of electrical equipment that operates as a single Bulk Electric System Element (e.g., a line, a generator, a shunt compensator, transformer, etc.)” In most cases, the criteria refer to a group of Facilities in a given location that supports the reliable operation of the BES. For example, for Transmission assets, the substation may be designated as the group of Facilities. However, in a substation that includes equipment that supports BES operations along with equipment that only supports Distribution

operations, the Responsible Entity may be better served to consider only the group of Facilities that supports BES operation. In that case, the Responsible Entity may designate the group of Facilities by location, with qualifications on the group of Facilities that supports reliable operation of the BES, as the Facilities that are subject to the criteria for categorization of BES Cyber Systems. Generation Facilities are separately discussed in the Generation section below. In CIP-002-5.1a, these groups of Facilities, systems, and equipment are sometimes designated as BES assets. For example, an identified BES asset may be a named substation, generating plant, or Control Center. Responsible Entities have flexibility in how they group Facilities, systems, and equipment at a location.

- In certain cases, a BES Cyber System may be categorized by meeting multiple criteria. In such cases, the Responsible Entity may choose to document all criteria that result in the categorization. This will avoid inadvertent miscategorization when it no longer meets one of the criteria, but still meets another.
- It is recommended that each BES Cyber System should be listed by only one Responsible Entity. Where there is joint ownership, it is advisable that the owning Responsible Entities should formally agree on the designated Responsible Entity responsible for compliance with the standards.

High Impact Rating (H)

This category includes those BES Cyber Systems, used by and at Control Centers (and the associated data centers included in the definition of Control Centers), that perform the functional obligations of the Reliability Coordinator (RC), Balancing Authority (BA), Transmission Operator (TOP), or Generator Operator (GOP), as defined under the Tasks heading of the applicable Function and the Relationship with Other Entities heading of the functional entity in the NERC Functional Model, and as scoped by the qualification in Attachment 1, Criteria 1.1, 1.2, 1.3 and 1.4. While those entities that have been registered as the above-named functional entities are specifically referenced, it must be noted that there may be agreements where some of the functional obligations of a Transmission Operator may be delegated to a Transmission Owner (TO). In these cases, BES Cyber Systems at these TO Control Centers that perform these functional obligations would be subject to categorization as high impact. The criteria notably specifically emphasize functional obligations, not necessarily the RC, BA, TOP, or GOP facilities. One must note that the definition of Control Center specifically refers to reliability tasks for RCs, Bas, TOPs, and GOPs. A TO BES Cyber System in a TO facility that does not perform or does not have an agreement with a TOP to perform any of these functional tasks does not meet the definition of a Control Center. However, if that BES Cyber System operates any of the facilities that meet criteria in the Medium Impact category, that BES Cyber System would be categorized as a Medium Impact BES Cyber System.

The 3000 MW threshold defined in criterion 1.2 for BA Control Centers provides a sufficient differentiation of the threshold defined for Medium Impact BA Control Centers. An analysis of BA footprints shows that the majority of Bas with significant impact are covered under this criterion.

Additional thresholds as specified in the criteria apply for this category.

Medium Impact Rating (M)

Generation

The criteria in Attachment 1’s medium impact category that generally apply to Generation Owner and Operator (GO/GOP) Registered Entities are criteria 2.1, 2.3, 2.6, 2.9, and 2.11. Criterion 2.13 for BA Control Centers is also included here.

- Criterion 2.1 designates as medium impact those BES Cyber Systems that impact generation with a net Real Power capability exceeding 1500 MW. The 1500 MW criterion is sourced partly from the Contingency Reserve requirements in NERC standard BAL-002, whose purpose is “to ensure the Balancing Authority is able to utilize its Contingency Reserve to balance resources and demand and return Interconnection frequency within defined limits following a Reportable Disturbance.” In particular, it requires that “as a minimum, the Balancing Authority or Reserve Sharing Group shall carry at least enough Contingency Reserve to cover the most severe single contingency.” The drafting team used 1500 MW as a number derived from the most significant Contingency Reserves operated in various Bas in all regions.

In the use of net Real Power capability, the drafting team sought to use a value that could be verified through existing requirements as proposed by NERC standard MOD-024 and current development efforts in that area.

By using 1500 MW as a bright-line, the intent of the drafting team was to ensure that BES Cyber Systems with common mode vulnerabilities that could result in the loss of 1500 MW or more of generation at a single plant for a unit or group of units are adequately protected.

- The drafting team also used additional time and value parameters to ensure the bright-lines and the values used to measure against them were relatively stable over the review period. Hence, where multiple values of net Real Power capability could be used for the Facilities’ qualification against these bright-lines, the highest value was used.
- In Criterion 2.3, the drafting team sought to ensure that BES Cyber Systems for those generation Facilities that have been designated by the Planning Coordinator or Transmission Planner as necessary to avoid BES Adverse Reliability Impacts in the planning horizon of one year or more are categorized as medium impact. In specifying a planning horizon of one year or more, the intent is to ensure that those are units that are identified as a result of a “long term” reliability planning, i.e that the plans are spanning an operating period of at least 12 months: it does not mean that the operating day for the unit is necessarily beyond one year, but that the period that is being planned for is more than 1 year: it is specifically intended to avoid designating generation that is required to be run to remediate short term emergency reliability issues. These Facilities may be designated as “Reliability Must Run,” and this designation is distinct from those generation Facilities designated as “must run” for market stabilization purposes. Because the use of the term “must run” creates some confusion in many areas, the drafting team chose to avoid using this term and instead drafted the requirement in more generic reliability language. In

particular, the focus on preventing an Adverse Reliability Impact dictates that these units are designated as must run for reliability purposes beyond the local area. Those units designated as must run for voltage support in the local area would not generally be given this designation. In cases where there is no designated Planning Coordinator, the Transmission Planner is included as the Registered Entity that performs this designation.

If it is determined through System studies that a unit must run in order to preserve the reliability of the BES, such as due to a Category C3 contingency as defined in TPL-003, then BES Cyber Systems for that unit are categorized as medium impact.

The TPL standards require that, where the studies and plans indicate additional actions, that these studies and plans be communicated by the Planning Coordinator or Transmission Planner in writing to the Regional Entity/RRO. Actions necessary for the implementation of these plans by affected parties (generation owners/operators and Reliability Coordinators or other necessary party) are usually formalized in the form of an agreement and/or contract.

- Criterion 2.6 includes BES Cyber Systems for those Generation Facilities that have been identified as critical to the derivation of IROLs and their associated contingencies, as specified by FAC-014-2, **Establish and Communicate System Operating Limits**, R5.1.1 and R5.1.3.

IROLs may be based on dynamic System phenomena such as instability or voltage collapse. Derivation of these IROLs and their associated contingencies often considers the effect of generation inertia and AVR response.

- Criterion 2.9 categorizes BES Cyber Systems for Special Protection Systems and Remedial Action Schemes as medium impact. Special Protection Systems and Remedial Action Schemes may be implemented to prevent disturbances that would result in exceeding IROLs if they do not provide the function required at the time it is required or if it operates outside of the parameters it was designed for. Generation Owners and Generator Operators which own BES Cyber Systems for such Systems and schemes designate them as medium impact.
- Criterion 2.11 categorizes as medium impact BES Cyber Systems used by and at Control Centers that perform the functional obligations of the Generator Operator for an aggregate generation of 1500 MW or higher in a single interconnection, and that have not already been included in Part 1.
- Criterion 2.13 categorizes as medium impact those BA Control Centers that “control” 1500 MW of generation or more in a single interconnection and that have not already been included in Part 1. The 1500 MW threshold is consistent with the impact level and rationale specified for Criterion 2.1.

Transmission

The SDT uses the phrases “Transmission Facilities at a single station or substation” and “Transmission stations or substations” to recognize the existence of both stations and substations. Many entities in industry consider a substation to be a location with physical borders (i.e. fence, wall, etc.) that contains at least an autotransformer. Locations also exist that do not contain autotransformers, and many entities in industry refer to those locations as stations (or switchyards). Therefore, the SDT chose to use both “station” and “substation” to refer to the locations where groups of Transmission Facilities exist.

- Criteria 2.2, 2.4 through 2.10, and 2.12 in Attachment 1 are the criteria that are applicable to Transmission Owners and Operators. In many of the criteria, the impact threshold is defined as the capability of the failure or compromise of a System to result in exceeding one or more Interconnection Reliability Operating Limits (IROLs). Criterion 2.2 includes BES Cyber Systems for those Facilities in Transmission Systems that provide reactive resources to enhance and preserve the reliability of the BES. The nameplate value is used here because there is no NERC requirement to verify actual capability of these Facilities. The value of 1000 MVARs used in this criterion is a value deemed reasonable for the purpose of determining criticality.
- Criterion 2.4 includes BES Cyber Systems for any Transmission Facility at a substation operated at 500 kV or higher. While the drafting team felt that Facilities operated at 500 kV or higher did not require any further qualification for their role as components of the backbone on the Interconnected BES, Facilities in the lower EHV range should have additional qualifying criteria for inclusion in the medium impact category.

It must be noted that if the collector bus for a generation plant (i.e. the plant is smaller in aggregate than the threshold set for generation in Criterion 2.1) is operated at 500kV, the collector bus should be considered a Generation Interconnection Facility, and not a Transmission Facility, according to the “Final Report from the Ad Hoc Group for Generation Requirements at the Transmission Interface.” This collector bus would not be a facility for a medium impact BES Cyber System because it does not significantly affect the 500kV Transmission grid; it only affects a plant which is below the generation threshold.

- Criterion 2.5 includes BES Cyber Systems for facilities at the lower end of BES Transmission with qualifications for inclusion if they are deemed highly likely to have significant impact on the BES. While the criterion has been specified as part of the rationale for requiring protection for significant impact on the BES, the drafting team included, in this criterion, additional qualifications that would ensure the required level of impact to the BES. The drafting team:
 - Excluded radial facilities that would only provide support for single generation facilities.
 - Specified interconnection to at least three transmission stations or substations to ensure that the level of impact would be appropriate.

The total aggregated weighted value of 3,000 was derived from weighted values related to three connected 345 kV lines and five connected 230 kV lines at a transmission station or substation.

The total aggregated weighted value is used to account for the true impact to the BES, irrespective of line kV rating and mix of multiple kV rated lines.

Additionally, in NERC's document "[Integrated Risk Assessment Approach – Refinement to Severity Risk Index](#)", Attachment 1, the report used an average MVA line loading based on kV rating:

- 230 kV → 700 MVA
- 345 kV → 1,300 MVA
- 500 kV → 2,000 MVA
- 765 kV → 3,000 MVA

In the terms of applicable lines and connecting "other Transmission stations or substations" determinations, the following should be considered:

- For autotransformers in a station, Responsible Entities have flexibility in determining whether the groups of Facilities are considered a single substation or station location or multiple substations or stations. In most cases, Responsible Entities would probably consider them as Facilities at a single substation or station unless geographically dispersed. In these cases of these transformers being within the "fence" of the substation or station, autotransformers may not count as separate connections to other stations. The use of common BES Cyber Systems may negate any rationale for any consideration otherwise. In the case of autotransformers that are geographically dispersed from a station location, the calculation would take into account the connections in and out of each station or substation location.
- Multiple-point (or multiple-tap) lines are considered to contribute a single weight value per line and affect the number of connections to other stations. Therefore, a single 230 kV multiple-point line between three Transmission stations or substations would contribute an aggregated weighted value of 700 and connect Transmission Facilities at a single station or substation to two other Transmission stations or substations.
- Multiple lines between two Transmission stations or substations are considered to contribute multiple weight values per line, but these multiple lines between the two stations only connect one station to one other station. Therefore, two 345 kV lines between two Transmission stations or substations would contribute an aggregated weighted value of 2600 and connect Transmission Facilities at a single station or substation to one other Transmission station or substation.

Criterion 2.5's qualification for Transmission Facilities at a Transmission station or substation is based on 2 distinct conditions.

1. The first condition is that Transmission Facilities at a single station or substation where that station or substation connect, at voltage levels of 200 kV or higher to three (3) other stations or substations, to three other stations or substations. This qualification is meant to ensure that connections that operate at voltages of 500 kV or higher are included in the count of connections to other stations or substations

as well.

2. The second qualification is that the aggregate value of all lines entering or leaving the station or substation must exceed 3000. This qualification does not include the consideration of lines operating at lower than 200 kV, or 500 kV or higher, the latter already qualifying as medium impact under criterion 2.4. : there is no value to be assigned to lines at voltages of less than 200 kV or 500 kV or higher in the table of values for the contribution to the aggregate value of 3000. The Transmission Facilities at the station or substation must meet both qualifications to be considered as qualified under criterion 2.5.

The Transmission Facilities at the station or substation must meet both qualifications to be considered as qualified under criterion 2.5.

- Criterion 2.6 include BES Cyber Systems for those Transmission Facilities that have been identified as critical to the derivation of IROLs and their associated contingencies, as specified by FAC-014-2, Establish and Communicate System Operating Limits, R5.1.1 and R5.1.3.
- Criterion 2.7 is sourced from the NUC-001 NERC standard, Requirement R9.2.2, for the support of Nuclear Facilities. NUC-001 ensures that reliability of NPIR's are ensured through adequate coordination between the Nuclear Generator Owner/Operator and its Transmission provider "for the purpose of ensuring nuclear plant safe operation and shutdown." In particular, there are specific requirements to coordinate physical and cyber security protection of these interfaces.
- Criterion 2.8 designates as medium impact those BES Cyber Systems that impact Transmission Facilities necessary to directly support generation that meet the criteria in Criteria 2.1 (generation Facilities with output greater than 1500 MW) and 2.3 (generation Facilities generally designated as "must run" for wide area reliability in the planning horizon). The Responsible Entity can request a formal statement from the Generation owner as to the qualification of generation Facilities connected to their Transmission systems.
- Criterion 2.9 designates as medium impact those BES Cyber Systems for those Special Protection Systems (SPS), Remedial Action Schemes (RAS), or automated switching Systems installed to ensure BES operation within IROLs. The degradation, compromise or unavailability of these BES Cyber Systems would result in exceeding IROLs if they fail to operate as designed. By the definition of IROL, the loss or compromise of any of these have Wide Area impacts.
- Criterion 2.10 designates as medium impact those BES Cyber Systems for Systems or Elements that perform automatic Load shedding, without human operator initiation, of 300 MW or more. The SDT spent considerable time discussing the wording of Criterion 2.10, and chose the term "Each" to represent that the criterion applied to a discrete System or Facility. In the drafting of this criterion, the drafting team sought to include only those Systems that did not require human operator initiation, and targeted in

particular those underfrequency load shedding (UFLS) Facilities and systems and undervoltage load shedding (UVLS) systems and Elements that would be subject to a regional Load shedding requirement to prevent Adverse Reliability Impact. These include automated UFLS systems or UVLS systems that are capable of Load shedding 300 MW or more. It should be noted that those qualifying systems which require a human operator to arm the system, but once armed, trigger automatically, are still to be considered as not requiring human operator initiation and should be designated as medium impact. The 300 MW threshold has been defined as the aggregate of the highest MW Load value, as defined by the applicable regional Load Shedding standards, for the preceding 12 months to account for seasonal fluctuations.

This particular threshold (300 MW) was provided in CIP, Version 1. The SDT believes that the threshold should be lower than the 1500MW generation requirement since it is specifically addressing UVLS and UFLS, which are last ditch efforts to save the Bulk Electric System and hence requires a lower threshold. A review of UFLS tolerances defined within regional reliability standards for UFLS program requirements to date indicates that the historical value of 300 MW represents an adequate and reasonable threshold value for allowable UFLS operational tolerances.

In ERCOT, the Load acting as a Resource (“LaaR”) Demand Response Program is not part of the regional load shedding program, but an ancillary services market. In general, similar demand response programs that are not part of the NERC or regional reliability Load shedding programs, but are offered as components of an ancillary services market do not qualify under this criterion.

- Criterion 2.12 categorizes as medium impact those BES Cyber Systems used by and at Control Centers and associated data centers performing the functional obligations of a Transmission Operator and that have not already been categorized as high impact.
- Criterion 2.13 categorizes as Medium Impact those BA Control Centers that “control” 1500 MW of generation or more in a single Interconnection. The 1500 MW threshold is consistent with the impact level and rationale specified for Criterion 2.1.

Low Impact Rating (L)

BES Cyber Systems not categorized in high impact or medium impact default to low impact. Note that low impact BES Cyber Systems do not require discrete identification.

Restoration Facilities

- Several discussions on the CIP Version 5 standards suggest entities owning Blackstart Resources and Cranking Paths might elect to remove those services to avoid higher compliance costs. For example, one Reliability Coordinator reported a 25% reduction of Blackstart Resources as a result of the Version 1 language, and there could be more entities that make this choice under Version 5.

In response, the CIP Version 5 drafting team sought informal input from NERC’s Operating and Planning Committees. The committees indicate there has already been a reduction in Blackstart Resources because of increased CIP compliance costs, environmental rules, and other risks; continued inclusion within Version 5 at a category that would very significantly increase compliance costs can result in further reduction of a vulnerable pool.

The drafting team moved from the categorization of restoration assets such as Blackstart Resources and Cranking Paths as medium impact (as was the case in earlier drafts) to categorization of these assets as low impact as a result of these considerations. This will not relieve asset owners of all responsibilities, as would have been the case in CIP-002, Versions 1-4 (since only Cyber Assets with routable connectivity which are essential to restoration assets are included in those versions). Under the low impact categorization, those assets will be protected in the areas of cyber security awareness, physical access control, and electronic access control, and they will have obligations regarding incident response. This represents a net gain to bulk power system reliability, however, since many of those assets do not meet criteria for inclusion under Versions 1-4.

Weighing the risks to overall BES reliability, the drafting team determined that this re-categorization represents the option that would be the least detrimental to restoration function and, thus, overall BES reliability. Removing Blackstart Resources and Cranking Paths from medium impact promotes overall reliability, as the likely alternative is fewer Blackstart Resources supporting timely restoration when needed.

BES Cyber Systems for generation resources that have been designated as Blackstart Resources in the Transmission Operator’s restoration plan default to low impact. NERC Standard EOP-005-2 requires the Transmission Operator to have a Restoration Plan and to list its Blackstart Resources in its plan, as well as requirements to test these Resources. This criterion designates only those generation Blackstart Resources that have been designated as such in the Transmission Operator’s restoration plan. The glossary term Blackstart Capability Plan has been retired.

Regarding concerns of communication to BES Asset Owners and Operators of their role in the Restoration Plan, Transmission Operators are required in NERC Standard EOP-005-2 to “provide the entities identified in its approved restoration plan with a description of any changes to their roles and specific tasks prior to the implementation date of the plan.”

- BES Cyber Systems for Facilities and Elements comprising the Cranking Paths and meeting the initial switching requirements from the Blackstart Resource to the first Interconnection point of the generation unit(s) to be started, as identified in the Transmission Operator’s restoration plan, default to the category of low impact: however, these systems are explicitly called out to ensure consideration for inclusion in the scope of the version 5 CIP standards. This requirement for inclusion in the scope is sourced from requirements in NERC standard EOP-005-2, which requires the Transmission Operator to include in its Restoration Plan the Cranking Paths and initial switching requirements from the Blackstart Resource and the unit(s) to be started.

Distribution Providers may note that they may have BES Cyber Systems that must be scoped in if they have Elements listed in the Transmission Operator’s Restoration Plan that are components of the Cranking Path.

Use Case: CIP Process Flow

The following CIP use case process flow for a generator Operator/Owner was provided by a participant in the development of the Version 5 standards and is provided here as an example of a process used to identify and categorize BES Cyber Systems and BES Cyber Assets; review, develop, and implement strategies to mitigate overall risks; and apply applicable security controls.

Overview (Generation Facility)

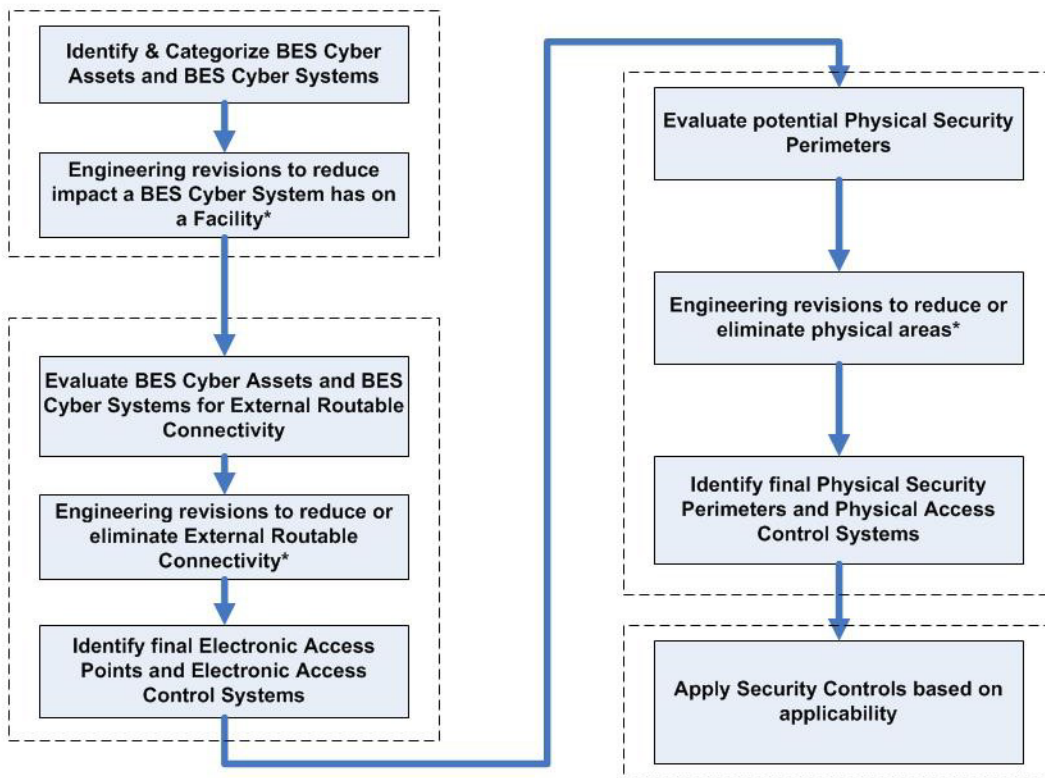

* - Engineering revisions will need to be reviewed for cost justification, operational/safety requirements, support requirements, and technical limitations.

Rationale

During development of this standard, text boxes were embedded within the standard to explain the rationale for various parts of the standard. Upon BOT approval, the text from the rationale text boxes was moved to this section.

Rationale for R1:

BES Cyber Systems at each site location have varying impact on the reliable operation of the Bulk Electric System. Attachment 1 provides a set of “bright-line” criteria that the Responsible Entity must use to identify these BES Cyber Systems in accordance with the impact on the BES. BES Cyber Systems must be identified and categorized according to their impact so that the appropriate measures can be applied, commensurate with their impact. These impact categories will be the basis for the application of appropriate requirements in CIP-003-CIP-011.

Rationale for R2:

The lists required by Requirement R1 are reviewed on a periodic basis to ensure that all BES Cyber Systems required to be categorized have been properly identified and categorized. The miscategorization or non-categorization of a BES Cyber System can lead to the application of inadequate or non-existent cyber security controls that can lead to compromise or misuse that can affect the real-time operation of the BES. The CIP Senior Manager’s approval ensures proper oversight of the process by the appropriate Responsible Entity personnel.

Appendix 1

Requirement Number and Text of Requirement

CIP-002-5.1, Requirement R1

R1. Each Responsible Entity shall implement a process that considers each of the following assets for purposes of parts 1.1 through 1.3:

- i. Control Centers and backup Control Centers;
 - ii. Transmission stations and substations;
 - iii. Generation resources;
 - iv. Systems and facilities critical to system restoration, including Blackstart Resources and Cranking Paths and initial switching requirements;
 - v. Special Protection Systems that support the reliable operation of the Bulk Electric System; and
 - vi. For Distribution Providers, Protection Systems specified in Applicability section 4.2.1 above.
- 1.1. Identify each of the high impact BES Cyber Systems according to Attachment 1, Section 1, if any, at each asset;
 - 1.2. Identify each of the medium impact BES Cyber Systems according to Attachment 1, Section 2, if any, at each asset; and
 - 1.3. Identify each asset that contains a low impact BES Cyber System according to Attachment 1, Section 3, if any (a discrete list of low impact BES Cyber Systems is not required).

Attachment 1, Criterion 2.1

2. Medium Impact Rating (M)

Each BES Cyber System, not included in Section 1 above, associated with any of the following:

- 2.1 Commissioned generation, by each group of generating units at a single plant location, with an aggregate highest rated net Real Power capability of the preceding 12 calendar months equal to or exceeding 1500 MW in a single Interconnection. For each group of generating units, the only BES Cyber Systems that meet this criterion are those shared BES Cyber Systems that could, within 15 minutes, adversely impact the reliable operation of any combination of units that in aggregate equal or exceed 1500 MW in a single Interconnection.

Questions

Energy Sector Security Consortium, Inc. (EnergySec) submitted a Request for Interpretation (RFI) seeking clarification of Criterion 2.1 of Attachment 1 in Reliability Standard CIP-002-5.1 regarding the use of the phrase “shared BES Cyber Systems.”

The Interpretation Drafting Team identified the following questions in the RFI:

1. Whether the phrase “shared BES Cyber Systems” means that the evaluation for Criterion 2.1 shall be performed individually for each discrete BES Cyber System at a single plant location, or collectively for groups of BES Cyber Systems?

2. Whether the phrase “shared BES Cyber Systems” refers to discrete BES Cyber Systems that are shared by multiple units, or groups of BES Cyber Systems that could collectively impact multiple units?
3. If the phrase applies collectively to groups of BES Cyber Systems, what criteria should be used to determine which BES Cyber Systems should be grouped for collective evaluation?

Responses

Question 1: Whether the phrase “shared BES Cyber Systems,” means that the evaluation for Criterion 2.1 shall be performed individually for each discrete BES Cyber System at a single plant location, or collectively for groups of BES Cyber Systems?

The evaluation as to whether a BES Cyber System is shared should be performed individually for each discrete BES Cyber System. In the standard language of CIP-002-5.1, there is no reference to or obligation to group BES Cyber Systems. Requirement R1, part 1.2 states “Identify *each* of the medium impact BES Cyber Systems according to Attachment 1, Section 2...” Further, the preamble of Section 2 of CIP-002-5.1 Attachment 1 states “*Each BES Cyber System...associated with any of the following [criteria].*” (emphasis added)

Additionally, the Background section of CIP-002-5.1 states that “[i]t is left up to the Responsible Entity to determine the level of granularity at which to identify a BES Cyber System within the qualifications in the definition of BES Cyber System.” The Background section also provides:

The Responsible Entity should take into consideration the operational environment and scope of management when defining the BES Cyber System boundary in order to maximize efficiency in secure operations. Defining the boundary too tightly may result in redundant paperwork and authorizations, while defining the boundary too broadly could make the secure operation of the BES Cyber System difficult to monitor and assess.

Question 2: Whether the phrase “shared BES Cyber Systems” refers to discrete BES Cyber Systems that are shared by multiple units, or groups of BES Cyber Systems that could collectively impact multiple units?

The phrase “shared BES Cyber Systems” refers to discrete BES Cyber Systems that are shared by multiple generation units.

The use of the term “shared” is also clarified in the NERC Frequently Asked Questions (FAQ) document issued by NERC Compliance to support implementation of the CIP Reliability Standards. FAQ #49 provides:

Shared BES Cyber Systems are those that are associated with any combination of units in a single Interconnection, as referenced in CIP-002-5.1, Attachment 1, impact rating criteria 2.1 and 2.2. For criterion 2.1 “BES Cyber Systems that could, within 15 minutes, adversely impact the reliable operation of any combination of units that in aggregate equal or exceed 1500 MW in a single Interconnection.” For criterion 2.2: “BES Cyber Systems that could, within 15 minutes, adversely impact the reliable operation of any combination of resources that in aggregate equal or exceed 1000 MVAR. Also refer to the Lesson Learned for CIP-002-5.1 Requirement R1: **Impact Rating of Generation Resource Shared BES Cyber Systems** for further information and examples.

Question 3: If the phrase applies collectively to groups of BES Cyber Systems, what criteria should be used to determine which BES Cyber Systems should be grouped for collective evaluation?

The phrase applies to each discrete BES Cyber System.