

NERC

NORTH AMERICAN ELECTRIC
RELIABILITY CORPORATION

Transmission Availability Data System (TADS) DEFINITIONS

September 11, 2008

to ensure
the reliability of the
bulk power system

116-390 Village Blvd., Princeton, NJ 08540
609.452.8060 | 609.452.9550 fax
www.nerc.com

Table of Contents

A.	TADS Population Definitions	1
1.	Element	1
2.	Protection System	1
3.	AC Circuit	1
4.	Transformer	3
5.	AC Substation	3
6.	AC/DC Terminal	3
7.	AC/DC Back-to-Back Converter	3
8.	DC Circuit	3
9.	Overhead Circuit	3
10.	Underground Circuit	3
11.	Circuit Mile	3
12.	Multi-Circuit Structure Mile	4
13.	Voltage Class	4
B.	Outage Reporting Definitions	4
1.	Automatic Outage	4
2.	Momentary Outage	4
3.	Sustained Outage	4
4.	AC Multi-Owner Common Structure Flag	5
5.	In-Service State	5
6.	Substation, Terminal, or Converter Name	8
7.	TO Element Identifier	8
8.	Outage Start Time	8
9.	Outage Duration	8
10.	Outage Continuation Flag	8
11.	Outage Identification (ID) Code	9
12.	Event	9
13.	Event Identification (ID) Code	9
14.	Event Type Number	9
15.	Fault Type	10
16.	Normal Clearing	11
C.	Outage Initiation Codes	11
1.	Element-Initiated Outage	11
2.	Other Element-Initiated Outage	11
3.	AC Substation-Initiated Outage	11
4.	AC/DC Terminal-Initiated Outage	11
5.	Other Facility-Initiated Outage	11
D.	Outage Mode Codes	12
1.	Single Mode Outage	12
2.	Dependent Mode Initiating Outage	12
3.	Dependent Mode Outage	12
4.	Common Mode Outage	12
5.	Common Mode Initiating Outage	12
E.	Cause Codes Types	13
1.	Initiating Cause Code	13
2.	Sustained Cause Code	13
F.	Cause Codes	14
1.	Weather, excluding lightning	14

2.	Lightning.....	14
3.	Environmental.....	14
4.	Contamination.....	14
5.	Foreign Interference.....	14
6.	Fire.....	14
7.	Vandalism, Terrorism or Malicious Acts.....	14
8.	Failed AC Substation Equipment.....	14
9.	Failed AC/DC Terminal Equipment.....	14
10.	Failed Protection System Equipment.....	14
11.	Failed AC Circuit Equipment.....	15
12.	Failed DC Circuit Equipment.....	15
13.	Vegetation.....	15
14.	Power System Condition.....	15
15.	Human Error.....	15
16.	Unknown.....	15
17.	Other.....	16
18.	Unavailable.....	16

A. TADS Population Definitions

1. Element

The following are Elements for which TADS data are to be collected:

1. AC Circuits ≥ 200 kV (Overhead and Underground)
2. Transformers with ≥ 200 kV low-side voltage
3. AC/DC Back-to-Back Converters with ≥ 200 kV AC voltage, both sides
4. DC Circuits with $\geq +/-200$ kV DC voltage

An Element may also be referred to as a “TADS Element” in the Manual. They have the same meaning.

2. Protection System

Protective relays, associated communication systems, voltage and current sensing devices, station batteries and DC control circuitry.¹

3. AC Circuit

A set of AC overhead or underground three-phase conductors that are bound by AC Substations. Radial circuits are AC Circuits.

The boundary of an AC Circuit extends to the transmission side of an AC Substation. A circuit breaker, Transformer, and their associated disconnect switches are not considered part of the AC Circuit but instead are defined as part of the AC Substation. The AC Circuit includes the conductor, transmission structure, joints and dead-ends, insulators, ground wire, and other hardware, including in-line switches. The AC Circuit includes in-line switches used to sectionalize portions of the AC Circuit as well as series compensation (capacitors and reactors) that is within the boundaries of the AC Circuit even if these ‘in-line’ devices are within an AC Substation. If these devices are not within the AC Circuit boundaries, they are not part of the AC Circuit but instead are part of the AC Substation. The diagrams on the next several pages explain this concept. The red arcs define the AC Circuit boundaries.²

In Figure 1 (next page), the series capacitor, bypass circuit breaker, and numerous disconnect switches are in a fenced AC Substation that is within the boundaries of the AC Circuit itself. When the series capacitor is connected and the bypass breaker is open, the capacitor and its disconnect switches are part of the AC Circuit. When the bypass breaker is closed, the bypass breaker and its disconnect switches (not shown) are part of the AC Circuit.

¹ This definition is in the current NERC *Glossary of Terms Used in Reliability Standards*.

² To simplify future diagrams, disconnect switches may not be shown.

Figure 1

Two in-line NC switches and one series capacitor are part of the AC Circuit between AC Substations A and B. When the bypass breaker and its disconnect switches (not shown) are closed and the capacitor switches opened, the breaker and its switches are part of the AC Circuit.

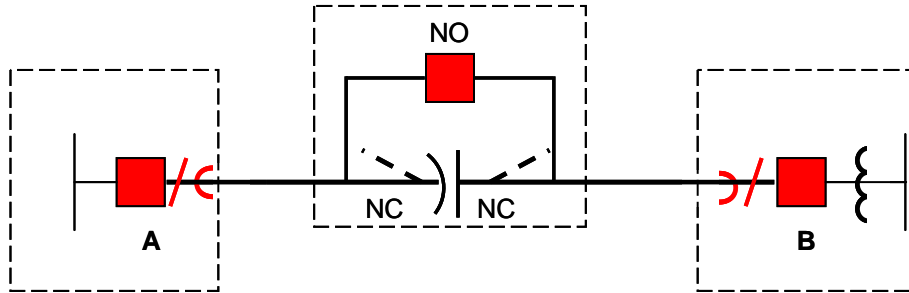

In Figure 2, the series reactor and in-line switches are part of the AC Circuit since they are within the AC Circuit boundaries even though they are within the AC Substation boundaries. In Figure 3, they are not part of the AC Circuit because they are not within the AC Circuit boundaries.

Figure 2

Two in-line NC switch and one series reactor are part of the AC Circuit between AC Substations A and B. The AC Circuit boundaries are the breaker disconnect switch in AC Substation A and the high-side disconnect switch on the Transformer in AC Substation B.

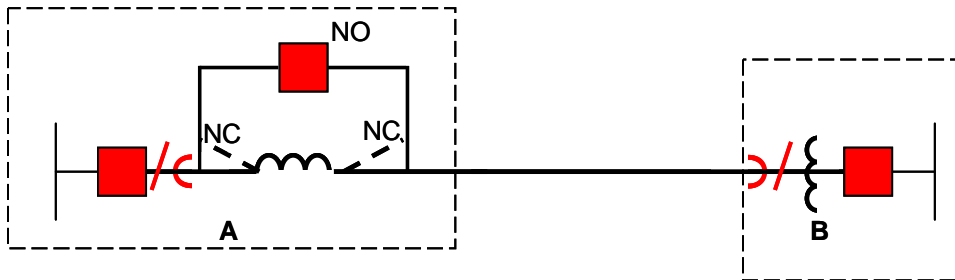
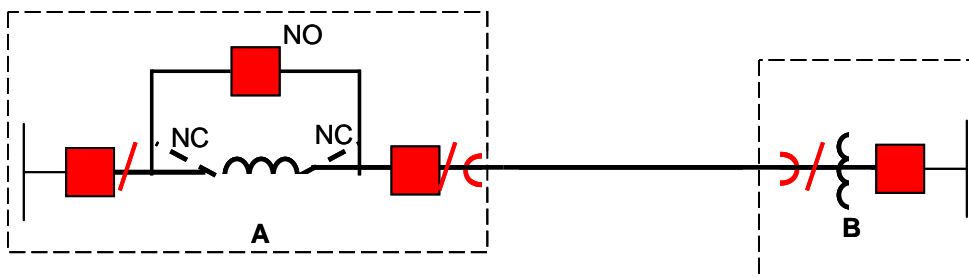

Figure 3

Two in-line NC switches and one series reactor are part of the AC Substation and not part of the AC Circuit between AC Substations A and B



4. Transformer

A bank comprised of three single-phase transformers or a single three-phase transformer. A Transformer is bounded by its associated switching or interrupting devices.

5. AC Substation

An AC Substation includes the circuit breakers and disconnect switches which define the boundaries of an AC Circuit, as well as other facilities such as surge arrestors, buses, Transformers, wave traps, motorized devices, grounding switches, and shunt capacitors and reactors. Series compensation (capacitors and reactors) is part of the AC Substation if it is not part of the AC Circuit. See the explanation in the definition of “AC Circuit.” Protection System equipment is excluded.

6. AC/DC Terminal

A terminal that includes all AC and DC equipment needed for DC operation such as PLC (power-line carrier) filters, AC filters, reactors and capacitors, Transformers, DC valves, smoothing reactors and DC filters. On the AC side, an AC/DC Terminal is normally bound by AC breakers at the AC Substation bus where it is connected. On the DC side, it is bound by DC converters and filters. Protection System equipment is excluded.

7. AC/DC Back-to-Back Converter

Two AC/DC Terminals in the same location with a DC bus between them. The boundaries are the AC breakers on each side.

8. DC Circuit

One pole of an Overhead or Underground DC line which is bound by an AC/DC Terminal on each end.

9. Overhead Circuit

An AC or DC Circuit that is not an Underground Circuit. A cable conductor AC or DC Circuit inside a conduit which is *not* below the surface is an Overhead Circuit. A circuit that is part Overhead and part Underground is to be classified based upon the majority characteristic (Overhead Circuit or Underground Circuit) using Circuit Miles.

10. Underground Circuit

An AC or DC Circuit that is below the surface, either below ground or below water. A circuit that is part Overhead Circuit and part Underground Circuit is to be classified based upon the majority characteristic (Overhead Circuit or Underground Circuit) using Circuit Miles.

11. Circuit Mile

One mile of either a set of AC three-phase conductors in an Overhead or Underground AC Circuit, or one pole of a DC Circuit. A one mile-long, AC Circuit tower line that carries two three-phase circuits (i.e., a double-circuit tower line) would equate to two Circuit Miles. A one mile-long, DC tower line that carries two DC poles would equate to two Circuit Miles. Also, a one mile-long, common-trenched, double-AC Circuit Underground duct bank that carries two three-phase circuits would equate to two Circuit Miles.

12. Multi-Circuit Structure Mile

A one-mile linear distance of sequential structures carrying multiple Overhead AC or DC Circuits. (Note: this definition is *not* the same as the industry term “structure mile.” A Transmission Owner’s Multi-Circuit Structure Miles will generally be less than its structure miles since not all structures contain multiple circuits.)

If a line section contains two or more Multi-Circuit Structures which form one or more multi-circuit spans, the total span length can be measured and the associated mileage should be reported in the ‘Multi-Circuit Structure Mile’ total inventory. If multiple circuits are connected to only one common structure, that structure should be ignored for outage and inventory mileage purposes.

13. Voltage Class

The following voltages classes will be used for reporting purposes:

1. 200 – 299 kV
2. 300 – 399 kV
3. 400 – 499 kV
4. 500 – 599 kV
5. 600 – 799 kV

For Transformers, the Voltage Class reported will be the high-side voltage, even though the cut-off voltage used in the definition is referenced on the low-side. Voltages are operating voltages.

B. Outage Reporting Definitions

1. Automatic Outage

An outage which results from the automatic operation of switching device, causing an Element to change from an In-Service State to a not In-Service State. A successful AC single-pole (phase) reclosing event is not an Automatic Outage.

2. Momentary Outage

An Automatic Outage with an Outage Duration less than one (1) minute. If the circuit recloses and trips again within less than a minute of the initial outage, it is only considered one outage. The circuit would need to remain in service for longer than one minute between the breaker operations to be considered as two outages.

3. Sustained Outage³

An Automatic Outage with an Outage Duration of a minute or greater.

³ The TADS definition of Sustained Outage is different that the NERC *Glossary of Term Used in Reliability Standards* definition of Sustained Outage which is presently only used in FAC-003-1. The glossary defines a Sustained Outage as follows: “The deenergized condition of a transmission line resulting from a fault or disturbance following an unsuccessful automatic reclosing sequence and/or unsuccessful manual reclosing procedure.” The definition is inadequate for TADS reporting for two reasons. First, it has no time limit that would distinguish a Sustained Outage from a Momentary Outage. Second, for a circuit with no automatic reclosing, the outage would not be “counted” if the TO has a successful manual reclosing under the glossary definition.

4. AC Multi-Owner Common Structure Flag

This flag identifies whether the outaged AC Circuit is on common structures with another circuit that is owned by a different Transmission Owner. This flag does not apply to DC Circuits which by default are all assumed to be on common structures with the circuits owned by the same Transmission Owner.

Flag Flag Interpretation

- 0 Not applicable. The circuit is not on common structures with another circuit, or the circuit is on common structures, but all circuits are reported by the same Transmission Owner. No analysis of the Event ID Code or the Event Type Number is required by the Regional Entity.
- 1 Circuit is on common structures with another circuit that is being reported by a different Transmission Owner. The Regional Entity will need to examine Outage Start Times with this same flag to determine whether a second circuit had an outage with nearly the same Outage Start Time, and if so, whether the TOs properly coordinated their Event ID Codes and Event Type Numbers.

5. In-Service State

An Element that is energized and fully connected to the system. Examples of reportable AC Circuit and Transformer Automatic Outages are illustrated below.

In Figure 4, AC Circuit A is bound by the disconnect switches (not shown)⁴ of two breakers, and Transformer A is bound by a breaker and a disconnect switch. AC Circuit B is bound by a breaker and a disconnect switch, and Transformer B is bound by a breaker and a disconnect switch. 230 kV bus fault opens the green breakers. The TADS Transformers each report an outage. AC Circuit A reports an outage, but AC Circuit B does not. It is defined by the breaker on the left and the disconnect switch on the right. Since the breaker associated with AC Circuit B did not experience and automatic operation, it was not outaged. It remains fully connected by the breaker and the disconnect switch.

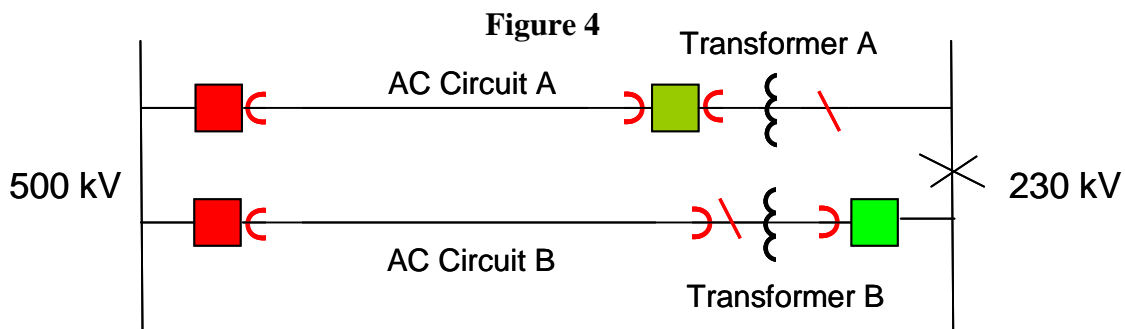

In Figure 5, we have a similar situation, except that the Transformers are not reportable since their low-side voltages are less than 200 kV. The AC Circuit outages are reportable exactly the same as in Figure 4; however, the Transformer outages are not reportable.

⁴ For simplification, disconnect switches may not be shown in some figures. When a circuit breaker or Transformer disconnect switch defines an AC Circuit boundary, we may just refer to the circuit breaker and the Transformer as defining the boundary without reference to their disconnect switches.

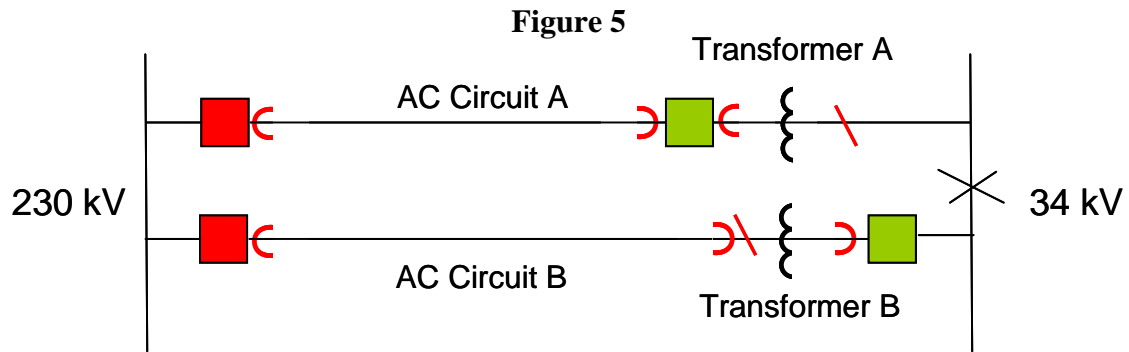

In Figure 6 (next page), AC Circuit 22, the only source connecting AC Substations A and B, has a fault. As a result, AC Circuits 84 and 88 are deenergized but remain fully connected. Three outages are reported: circuits 22, 84, and 88. None of them meet the In-Service State requirement of being energized *and* fully connected.

Figure 6

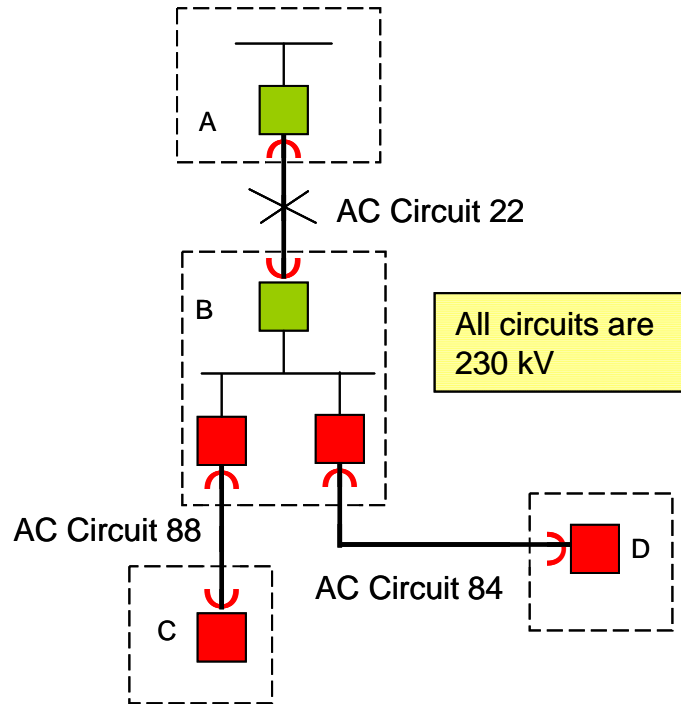

An exception that an Element be “fully connected” to be considered in an In-Service State is provided for a multi-terminal AC Circuit with a Transformer on one terminal that shares a breaker with the circuit.

Figure 7

Figure 8

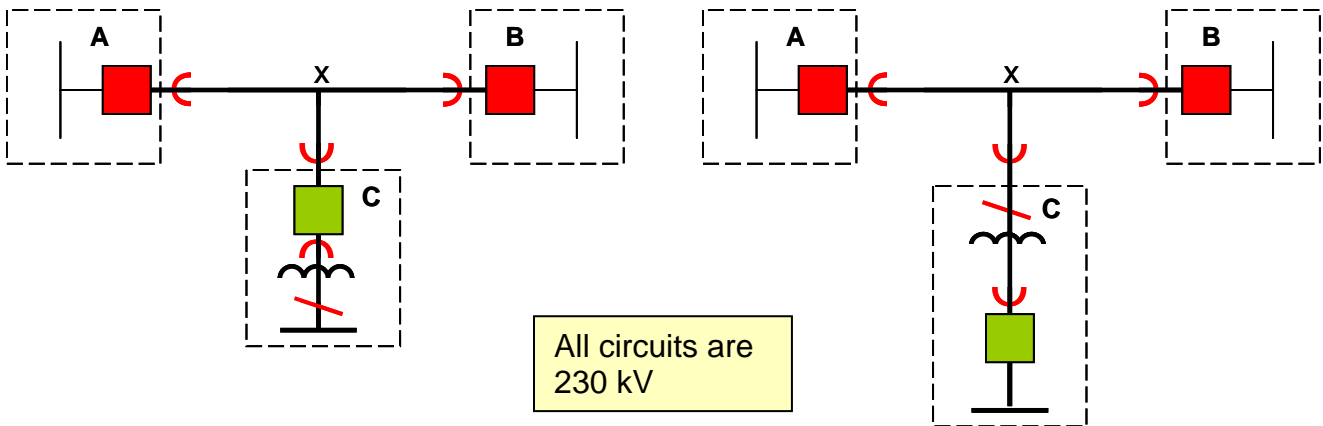

In both figures, the AC Circuit is bounded by AC Substations “A,” “B,” and “C” as indicated by the red arcs. Each Transformer’s boundaries are the red disconnect switch and the red arc before the breaker. Note that the Transformer in either figure may *or* may not be a reportable Element (i.e., one with a low-side voltage ≥ 200 kV).

Assume that each Transformer is out of service as a result of the operation of its associated breaker (indicated in green). In Figure 7, the AC Circuit would normally be considered out of service since the breaker at AC Substation C, which is shared by the AC Circuit and the Transformer, is open. Nevertheless, if all other portions of the AC Circuit are in service, the entire AC Circuit is considered to be in an In-Service State even if the Transformer is out of service. Because TADS does not recognize partial outage states, the multi-terminal exception above was developed so as to not overstate the outage contribution of a multi-terminal configuration of this type. In Figure 8, the open breaker is not shared by the AC Circuit, and the AC Circuit remains fully connected. Thus, the exception does not apply in this case since the AC Circuit is fully connected even though the Transformer out of service.

6. Substation, Terminal, or Converter Name

For Automatic Outages of AC Circuits and DC Circuits, the termination name at each end of the circuit will be reported to help identify *where* the circuit is located. For AC Circuits, these are the AC Substation Names; for DC Circuits, these are the AC/DC Terminal Names. For AC/DC Back-to-Back Converters, this is the Converter Station Name.

7. TO Element Identifier

An alphanumeric name that the TO must enter to identify the Element which is outaged (e.g., a circuit name.)

8. Outage Start Time

The date (mm/dd/yyyy) and time (hhhh:mm), rounded to the minute, that the Automatic Outage of an Element started. Outage Start Time is expressed in Coordinated Universal Time (UTC), not local time. TADS data is reported on a calendar-year basis, and the TADS Data Reporting Instruction Manual addresses the recording of the Outage Start time of a Sustained Outage that starts in one reporting year and concludes in another reporting year.

9. Outage Duration

The amount of time from the Outage Start Time to when the Element is fully restored to its original or to normal configuration, including equipment replacement. Outage Duration is expressed as hours and minutes, rounded to the nearest minute. Momentary Outages are assigned a time of zero Outage Duration. TADS data is reported on a calendar-year basis, and the TADS Data Reporting Instruction Manual addresses the recording of the Outage Durations of an outage that starts in one reporting year and concludes in another reporting year.

10. Outage Continuation Flag

Not all outages start and end in the same reporting year. This flag describes that characteristic for an outage.

<u>Flag</u>	<u>Flag Interpretation</u>
0	Outage began and ended within the reporting year
1	Outage began in the reporting year but continues into the next reporting year.
2	Outage started in another (previous) reporting year.

11. Outage Identification (ID) Code

A unique alphanumeric identifier assigned by the Transmission Owner to identify the reported outage of an Element.

12. Event

An Event is a transmission incident that results in the Automatic Outage (Sustained or Momentary) of one or more Elements.

13. Event Identification (ID) Code

A unique alphanumeric identifier assigned by the Transmission Owner to an Event. Because outages that begin in one reporting year and end in the next reporting year must have the same Event ID Code, the code must have the reporting year appended to it to ensure its uniqueness. For example, an Event ID Code may be W324-2008. This unique Event ID Code establishes an easy way to identify which Automatic Outages are related to one another as defined by their Outage Mode Codes (see Section D).

1. An Event associated with a Single Mode Outage will have just one Event ID Code.
2. Each outage in a related set of two or more outages (e.g., Dependent Mode, Dependent Mode Initiating, Common Mode, or Common Mode Initiating) shall be given the same Event ID Code.

14. Event Type Number

A code that describes the type of Automatic Outage. The following Event Type Numbers will be used initially:

Event Type No.	Table 1 Category from the TPL Standards	Description
10	B	Automatic Outage of an AC Circuit or Transformer with Normal Clearing.
20	B	Automatic Outage of a DC Circuit with Normal Clearing.
30	C	Automatic Outage of two ADJACENT AC Circuits on common structures with Normal Clearing.
40	C	Automatic Outage of two ADJACENT DC Circuits on common structures with Normal Clearing.
50	NA	Other - please describe the event (optional)

To qualify for an Event Type No. 30 or 40, the outages must be a direct result of the circuits occupying common structures. These characteristics will generally apply.

1. The Outage Initiation Codes are either Element-Initiated or Other-Element Initiated.
2. The Outage Mode Codes are one of the following: (a) Dependent Mode Initiating (one outage) and Dependent Mode (second outage); (b) Common Mode Initiating and Common Mode (two outages); or (c) both Common Mode (two outages).

Event Type No. 30 and 50 Examples

These are examples of Events that are Event Type No. 30:

1. A tornado outages two circuits on common structures. In this example, the outage is Element-Initiated and Common Mode. This is an Event Type No. 30 because the loss of both circuits was directly related to them being on the same structures.

2. On one circuit, a conductor breaks (outaging the circuit), and the conductor swings into a second circuit on common structures. The first circuit outage is Element-Initiated and Dependent Mode Initiating; the second circuit outage is Other-Element Initiated and Dependent Mode. This is an Event Type No. 30 because the second circuit's outage was a result of it being on common structures as the first circuit.

These Events are not an Event Type No. 30; instead, they are an Event Type No. 50.

1. Two AC Circuits on common structures are outaged due to a bus fault in the AC Substation where the circuits terminate. Both outages are Substation-Initiated and Common Mode. Because the outages are not a result of the two circuits being on common structures, it is not an Event Type No. 30. Therefore, it is an Event Type No. 50.
2. Two AC Circuits are on common structures and terminate at the same bus. Lightning strikes one AC Circuit, but the breaker fails to open due to a failure of a relay to operate properly. The second circuit, which is connected to the same bus, is outaged as a result of the failure of first circuit's breaker to open. The first outage is an Element-Initiated and Dependent Mode Initiating; the second outage is Other Facility-Initiated and Dependent Mode. (Note: the relay is excluded as part of an AC Substation, making the Outage Initiation Code "Other-Facility Initiated" and not "Substation-Initiated.") Because the outages are not a result of the two circuits being on common structures, it is not an Event Type No. 30. Therefore, it is an Event Type No. 50.

15. Fault Type

The descriptor of the fault, if any, associated with each Automatic Outage of an Element. Several choices are possible for each Element outage:

1. No fault
2. Phase-to-phase fault (P-P)
3. Single phase-to-ground fault (P-G)
4. Phase-to-phase-to-ground (P-P-G), 3P, or 3P-G fault
5. Unknown fault type

The Fault Type for each Element outage may be determined from recorded relay targets or by other analysis. TOs should use the best available data to determine (1) whether a fault occurred on each outaged Element and, if so, (2) what type of fault occurred. Relay targets should be documented as soon as practical after a fault and the targets re-set to prepare for the next fault. If a single fault results in several Element outages, the protective relay targets associated with each Element indicate the Fault Type for that Outage. Relay targets are not a fool proof method to determine the Fault Type; however, they may be the best available data to determine Fault Type. An Element whose relays did not indicate a fault should be reported as "No fault."

Example: A 500 kV AC Circuit has a single phase-to-ground fault that also results in an Outage of a 500/230 kV Transformer. The AC Circuit outage would have "Single phase-to-ground fault (P-G)" selected as the Fault Type, while the Transformer would have "No fault" selected.

16. Normal Clearing

A protection system operates as designed and the fault is cleared in the time normally expected with proper functioning of the installed protection system.⁵

C. Outage Initiation Codes

The Outage Initiation Codes describe *where* an Automatic Outage was initiated on the power system.

1. Element-Initiated Outage

An Automatic Outage of an Element that is initiated on or within the Element that is outaged.

2. Other Element-Initiated Outage

An Automatic Outage of an Element that is initiated by another Element and not by the Element that is outaged.

3. AC Substation-Initiated Outage

An Automatic Outage of an Element that is initiated on or within AC Substation facilities.

4. AC/DC Terminal-Initiated Outage

An Automatic Outage of an Element that is initiated on or within AC/DC Terminal facilities.

5. Other Facility-Initiated Outage

An Automatic Outage that is initiated on or within other facilities. “Other facilities” include any facilities not includable in any other Outage Initiation Code. (Note: An Automatic Outage initiated on a Transformer that is *not* an Element is considered an AC Substation or an AC/DC Terminal-Initiated Outage since the Transformer would be considered part of an AC Substation or AC/DC Terminal.)

Outage Initiation Code Examples

1. A Transformer which is an Element is outaged. Is its outage an Element-Initiated Outage or a Substation-Initiated Outage? It depends. If the outage initiated on or within the Element (e.g., an internal fault or a cracked insulator that caused a fault), the outage is Element-Initiated, even though the Transformer is in a Substation. However, if the Transformer outage was not due to the Transformer itself but due, for example, to a failed circuit breaker, it is Substation-Initiated.
2. An AC Circuit which is an Element has an outage that was initiated by a non-Element AC Circuit. The Element outage is Other Facility-Initiated.
3. An AC Circuit Outage was initiated by an Element Transformer outage. The AC Circuit Outage is Other Element-Initiated.

⁵ This definition is in the current NERC *Glossary of Terms Used in Reliability Standards*.

D. Outage Mode Codes

The Outage Mode Code describes whether an Automatic Outage is related to other Automatic Outages.

1. Single Mode Outage

An Automatic Outage of a single Element which occurred independent of any other outages (if any).

2. Dependent Mode Initiating Outage

An Automatic Outage of a single Element that initiates one or more subsequent Element Automatic Outages.

3. Dependent Mode Outage

An Automatic Outage of an Element which occurred as a result of an initiating outage, whether the initiating outage was an Element outage or a non-Element outage. (Note: to re-emphasize, a Dependent Mode Outage must be a result of another outage.)

4. Common Mode Outage

One of two or more Automatic Outages with the same Initiating Cause Code and where the outages are not consequences of each other and occur nearly simultaneously (i.e., within cycles or seconds of one another).

5. Common Mode Initiating Outage

A Common Mode Outage that initiates one or more subsequent Automatic Outages.

Dependent Mode and Common Mode Outage Examples

1. A Dependent Mode Outage involves two outages, but one of the outages can be a non-Element outage. Therefore, not all Dependent Mode Outages will have an associated Dependent Mode Initiating Outage. If the initiating outage is one of the four defined Elements, that outage will be a Dependent Mode Initiating Outage, and the resulting second Element outage will be a Dependent Mode Outage. For example, suppose a 500 kV AC Circuit is outaged as a result of a 500/230 kV Transformer outage. The AC Circuit outage is a Dependent Mode Outage, and the Transformer outage is a Dependent Mode Initiating Outage. However, if an outage is not initiated by an Element, it will not have an associated Dependent Mode Initiating Outage. If the Transformer in the previous example had been a 345/138 kV Transformer and the AC Circuit a 345 kV circuit, the Transformer would not be an Element and, therefore, the AC Circuit outage would not have an associated Dependent Mode Initiating Outage. The AC Circuit outage would be classified as a Dependent Mode Outage since it was the result of a non-Element outage.
2. A Common Mode Outage involves the two outages, but unlike a Dependent Mode Outage, both outages must be Elements. In addition, one outage must not cause the second outage to occur; i.e., the two outages are not consequences of each other. In addition, they must occur nearly simultaneously. As an example, suppose that lightning strikes two AC Circuits in the same right of way (but not

on a common structure) and both circuits are outaged nearly simultaneously. Assume no further outages occur. Both are Common Mode Outages. Now assume the same scenario with a slight difference: one AC Circuit clears normally, the second AC Circuit does not, and there is a circuit breaker failure, resulting in the outage of a third AC Circuit. The first AC Circuit outage is a Common Mode Outage. The second AC Circuit outage is a Common Mode Initiating Outage, with the third AC Circuit outage a Dependent Mode Outage.

E. Cause Codes Types

1. Initiating Cause Code

The Cause Code that describes the initiating cause of the outage.

2. Sustained Cause Code

The Cause Code that describes the cause that contributed to the longest duration of the outage. Momentary Outages do not have a Sustained Cause Code.

Initiating and Sustained Cause Code Examples

Suppose a lightning strike on an AC Circuit that should have cleared normally becomes a Sustained Outage because of breaker failure. “Lightning” is the Initiating Cause Code and “Failed AC Substation Equipment” is the Sustained Cause Code.

To illustrate the meaning of the phrase “contributed to the longest duration” in the definition above, suppose that lightning caused a conductor to break (“Failed AC Circuit Equipment”) and that the breaker for the circuit also failed (“Failed AC Substation Equipment”). This example has two possible Sustained Outage Cause Codes, and the one to select is the one that contributed to the longest duration. If the conductor was repaired before the circuit breaker, then “Failed AC Substation Equipment” is the Sustained Cause Code since the circuit breaker outage contributed to the longest duration.

Special Exception for 2008 Reporting: For reporting in 2008, Transmission Owners should supply both the Initiating and Sustained Cause Codes if they have them available. However, if both Cause Codes are not available, at least one Cause Code, either Initiating or Sustained, must be supplied for a Sustained Outage. (Momentary Outages still must have their Initiating Cause Code reported.) As an example, suppose a TO only has the Initiating Outage Cause Code available to it for Sustained Outages. The Initiating Cause Code would be entered for each outage, and the appropriate Sustained Cause Code would be “Unavailable.” On the other hand, suppose only a Sustained Cause Code is available. Sustained Outages would then have their Initiating Outage Codes reported as “Unavailable.” The “Unavailable” code will be deleted in 2009 when TOs are expected to have both Initiating and Sustained Cause Codes available.

F. Cause Codes

1. Weather, excluding lightning

Automatic Outages caused by weather such as snow, extreme temperature, rain, hail, fog, sleet/ice, wind (including galloping conductor), tornado, microburst, dust storm, and flying debris caused by wind.

2. Lightning

Automatic Outages caused by lightning.

3. Environmental

Automatic Outages caused by environmental conditions such as earth movement (including earthquake, subsidence, earth slide), flood, geomagnetic storm, or avalanche.

4. Contamination

Automatic Outages caused by contamination such as bird droppings, dust, corrosion, salt spray, industrial pollution, smog, or ash.

5. Foreign Interference

Automatic Outages caused by foreign interference from such objects such as an aircraft, machinery, a vehicle, a train, a boat, a balloon, a kite, a bird (including streamers), an animal, flying debris not caused by wind, and falling conductors from one line into another. Foreign Interference is not due to an error by a utility employee or contractor. Categorize these as “Human Error.”

6. Fire

Automatic Outages caused by fire or smoke.

7. Vandalism, Terrorism or Malicious Acts

Automatic Outages caused by intentional activity such as shot conductors or insulators, removing bolts from structures, and bombs.

8. Failed AC Substation Equipment

Automatic Outages caused by the failure of AC Substation; i.e., equipment “inside the substation fence” including Transformers and circuit breakers but excluding Protection System equipment. Refer to the definition of “AC Substation.”

9. Failed AC/DC Terminal Equipment

Automatic Outages caused by the failure of AC/DC Terminal equipment; i.e., equipment “inside the terminal fence” including PLC (power-line carrier) filters, AC filters, reactors and capacitors, Transformers, DC valves, smoothing reactors, and DC filters but excluding Protection System equipment. Refer to the definition of “AC/DC Terminal.”

10. Failed Protection System Equipment

Automatic Outages caused by the failure of Protection System equipment. Includes any relay and/or control misoperations *except* those that are caused by incorrect relay or control settings that do not coordinate with other protective devices. Categorize these as “Human Error”.

11. Failed AC Circuit Equipment

Automatic Outages related to the failure of AC Circuit equipment, i.e., overhead or underground equipment “outside the substation fence.” Refer to the definition of “AC Circuit.”

12. Failed DC Circuit Equipment

Automatic Outages related to the failure DC Circuit equipment, i.e., overhead or underground equipment “outside the terminal fence.” Refer to the definition of “DC Circuit.” However, include the failure of a connecting DC bus within an AC/DC Back-to-Back Converter in this category.

13. Vegetation

Automatic Outages (both Momentary and Sustained) caused by vegetation, with the exception of the following exclusions which are contained in FAC-003-1:

1. Vegetation-related outages that result from vegetation falling into lines from outside the right of way that result from natural disasters shall not be considered reportable with the Vegetation Cause Code. Examples of disasters that could create non-reportable Vegetation Cause Code outages include, but are not limited to, earthquakes, fires, tornados, hurricanes, landslides, wind shear, major storms as defined either by the Transmission Owner or an applicable regulatory body, ice storms, and floods, and
2. Vegetation-related outages due to human or animal activity shall not be considered reportable under the Vegetation Cause Code. Examples of human or animal activity that could cause a non-reportable Vegetation Cause Code outage include, but are not limited to, logging, animal severing tree, vehicle contact with tree, arboricultural activities or horticultural or agricultural activities, or removal or digging of vegetation.

Outages that fall under the exclusions should be reported under another Cause Code and not the Vegetation Cause Code.

14. Power System Condition

Automatic Outages caused by power system conditions such as instability, overload trip, out-of-step, abnormal voltage, abnormal frequency, or unique system configurations (e.g., an abnormal terminal configuration due to existing condition with one breaker already out of service).

15. Human Error

Automatic Outages caused by any incorrect action traceable to employees and/or contractors for companies operating, maintaining, and/or providing assistance to the Transmission Owner will be identified and reported in this category. Also, any human failure or interpretation of standard industry practices and guidelines that cause an outage will be reported in this category.

16. Unknown

Automatic Outages caused by unknown causes should be reported in this category.

17. Other

Automatic Outages for which the cause is known; however, the cause is not included in the above list.

18. Unavailable

Use for Sustained Outages for which either the Initiating or Sustained Cause Codes are unavailable to the Transmission Owner. If a Transmission Owner uses this code for Sustained Outages, it should be used on only *one* type of Cause Code (Initiating or Sustained), whichever is unavailable. If during 2008, both Cause Codes become available to the Transmission Owner, stop using “Unavailable.” The “Unavailable” code will be withdrawn in 2009.