

**NERC**  
**Transmission Availability Data System (TADS)**  
**DATA REPORTING INSTRUCTION MANUAL**

~~November 20~~January X, 2007

## Version History

Version Date	Major Changes
October 17, 2007	New
November <del>X</del> 20, 2007	<p><u>P. 4. Table 1.5, third row in the “Date” column.</u> Change: December 17, 2007 was changed to January 15, 2008.</p> <p><u>P.7, Section 2.1.</u> Addition: A new paragraph was added that defines “tie line” for TADS purposes.</p> <p><u>P. 14. Table 5, Column A.</u> Addition: “For the special first quarter submittal, use “2008” and not “2008Q1.” That way the Event ID Codes can be used for the 2008 annual submittal as well.”</p> <p><u>P. 62. AC Circuit that is directly connected to a TADS Transformer.</u> Change: The AC Circuit and Transformer both return to service when both breakers G and H are closed. The exception for a line connected to a transformer described in the definition of In-Service State” in Appendix 6, pp. 3-4 only applies to multi-terminal circuits, not two-terminal circuits.</p> <p><u>P. 67. Form 4.1.</u></p> <p>Outage Code D1: This code is associated with the example on p. 62 that was changed. Change: The Outage Duration was changed to 3 minutes from 1 minute</p> <p>Outage ID Codes H2 and H3: Change: The Outage Initiation Code was changed to “Other Facility-Initiated” since the Protection System is not part of an AC Substation.</p> <p><u>P. 67. Form 4.3.</u></p> <p>Outage ID Code B2: Changes: The Outage Initiation Code was changed to “Other Element-Initiated” (an AC Circuit) since Transformer did not initiate the reported Transformer outage. Sustained Cause Code changed “Failed AC Equipment” (coding error).</p> <p>Outage ID Code D2: The Outage Initiation Code was changed to “Other Element-Initiated” (an AC Circuit) since Transformer did not initiate the reported Transformer outage.</p> <p>Outage ID Code G: The Fault Type was changed to “None” since there was no fault, just a relay misoperation. The Outage Initiation Code was changed to “Other Facility-Initiated” since the Protection System is not part of the AC Substation.</p>
<a href="#">January X, 2008</a>	<p><a href="#">P. 7, Sections 2 and 2.1</a> <a href="#">Clarified that only jointly-owned circuits are to be reported on Form 2.1. We previously required tie lines to be reported even if they were not jointly owned.</a></p> <p><a href="#">P. 8, Table 2.1 and p. 18</a> <a href="#">Added the ability to specify a three-terminal circuit with a new column D. Other columns letters were changed accordingly</a></p> <p><a href="#">P. 8, Table 2.2 and p. 19</a> <a href="#">Added a “Not Applicable” column D to keep the column labeling consistent between Forms 2.1 and 2.2.</a></p> <p><a href="#">Appendix 6 (Definitions), p. 1</a> <a href="#">For “AC Circuit,” clarified that in-line sectionalizing switches inside an AC Substation are part of the AC Circuit.</a></p> <p><a href="#">Appendix 6 (Definitions), pp 6-7</a></p>

	<p><a href="#">Added a more complete description of Fault Type, including clarifying that it applies to each outaged Element.</a></p> <p><a href="#">P. 67, Form 4.3</a></p> <p><a href="#">Outage ID Code B2 and D2: Changes: The Fault Type was changed to “No fault” because the Transformer did not experience a fault.</a></p>
--	---

## Table of Contents

<b>1. INTRODUCTION .....</b>	<b>4</b>
1.1 MANUAL SUGGESTIONS .....	4
1.2 TADS DEFINITIONS .....	4
1.2.1. AC and DC Voltage Classes .....	4
1.3 FORMS OVERVIEW .....	4
1.4 DATA CONFIDENTIALITY .....	6
1.5 2008 REPORTING SCHEDULE .....	7
1.5.1. TADS Data Entry and Analysis Software .....	8
1.6 TADS TRAINING.....	8
1.7 TADS HELP.....	8
1.8 ADMINISTRATIVE FORMS WITH TRANSMISSION OWNER INFORMATION .....	9
1.8.1. Form 1.1 Non-Reporting Transmission Owner Statement .....	9
1.8.2. Form 1.2 Reporting Transmission Owner Information .....	9
<b>2. FORMS FOR <del>TIE LINES AND</del> JOINTLY-OWNED FACILITIES.....</b>	<b>9</b>
2.1 FORM 2.1 <del>TIE LINES AND</del> JOINTLY-OWNED AC AND DC CIRCUITS .....	10
2.2 FORM 2.2 JOINTLY-OWNED AC/DC BACK-TO-BACK CONVERTER .....	11
<b>3. FORMS FOR ELEMENT INVENTORY AND SUMMARY OUTAGE DATA</b>	<b>11</b>
3.1 FORM 3.1 AC AND DC INVENTORY DATA.....	11
3.2 FORM 3.2 TRANSFORMER INVENTORY DATA .....	14
3.3 FORM 3.3 AC/DC BTB CONVERTER INVENTORY DATA.....	15
3.4 FORM 3.4 SUMMARY AUTOMATIC OUTAGE DATA.....	15
<b>4. FORMS FOR DETAILED AUTOMATIC OUTAGE DATA.....</b>	<b>16</b>
4.1 OUTAGES THAT CONTINUE BEYOND THE END OF THE YEAR .....	17
<b>5. FORM FOR EVENT ID CODE AND EVENT TYPE NUMBER DATA .....</b>	<b>19</b>
Appendix 1 Administrative Forms with Transmission Owner Information.....	20
1.1. Non-Reporting Transmission Owner Statement .....	20
1.2. Reporting Transmission Owner Information .....	21
Appendix 2 Forms for <del>Tie Lines and</del> Jointly-Owned Facilities.....	22
2.1. <del>Tie Lines and</del> Jointly-Owned AC and DC Circuits .....	22
2.2. Jointly-Owned AC/DC Back-to-Back Converters .....	23
Appendix 3 Forms for Element Inventory and Summary Outage Data .....	24
3.1. AC and DC Circuit Inventory Data .....	24
3.2. Transformer Inventory Data .....	25
3.3. AC/DC Back-to-Back Converter Inventory Data .....	26
3.4. Summary Automatic Outage Data .....	27
Appendix 4 Forms for Detailed Automatic Outage Data .....	28
4.1. AC Circuit Detailed Automatic Outage Data .....	28
4.2. DC Circuit Detailed Automatic Outage Data .....	29
4.3. Transformer Detailed Automatic Outage Data .....	30
4.4. AC/DC Back-to-Back Converter Detailed Outage Data .....	31
Appendix 5 Form for Event ID Code and Event Type Number Data .....	32
Appendix 6 TADS Definitions .....	33
Appendix 7 Inventory Data Examples .....	43
Appendix 8 Detailed Outage Data Examples.....	58
Appendix 9 Regional Entity and NERC Contacts .....	69

# 1. Introduction

TADS is described in the *Transmission Availability Data System Revised Final Report* (“Report”) that was approved by the Planning Committee on September 26, 2007. The Report can be found at <http://www.nerc.com/~filez/tadstf.html>, and it provides background on how TADS was developed.

We developed this *TADS Data Reporting Instruction Manual* (“Manual”) to provide TOs with help in completing the data forms for Phase I TADS. This [January X, 2008 version is an update of a prior November 20, 2007 version](#) ~~is an update of a prior October 17, 2007 version~~. There are data forms, most of which have subparts, for each of the Elements for which outage information is reported. This list shows those Elements:

- AC Circuits  $\geq 200$  kV (Overhead and Underground Circuits). Radial circuits are included.
- DC Circuits with  $\geq \pm 200$  kV DC voltage
- Transformers with  $\geq 200$  kV low-side voltage
- AC/DC Back-to-Back Converters with  $\geq 200$  kV AC voltage, both sides

## 1.1 Manual Suggestions

We encourage you to send suggestions for improvements to this Manual to [tads@nerc.net](mailto:tads@nerc.net). This includes everything from typos to unclear instructions. We will note changes in subsequent updated versions of the Manual.

## 1.2 TADS Definitions

The TADS Definitions document is a stand-alone document that is in Appendix 6. Most of the terms in the forms have specific definitions which may differ from the common usage of the same term. For example, the term “AC Circuit” is specifically defined and includes both two- and three-terminal circuits. Therefore, it is important that the TO refer to the definitions when completing the forms.

### 1.2.1. AC and DC Voltage Classes

Appendix 6 defines five Voltage Classes. These cover the range of possible AC and DC voltages. For reporting, however, we have defined four AC Voltage Classes by combining two voltage ranges, 400-499 kV and 500-599 kV, into one 400-599 kV class since there are no AC Elements in the 400-499 kV range in North America. However, all five voltage classes are available for DC Elements.

#### AC Voltage Classes

200-299 kV  
300-399 kV  
400-599 kV  
600-799 kV

#### DC Voltage Classes

200-299 kV  
300-399 kV  
400-499 kV  
500-599 kV  
600-799 kV

## 1.3 Forms Overview

The forms and their subparts are shown in Appendices 1-5. These are depicted as pictures of the worksheets contained in a TADS Forms spreadsheet. The spreadsheet can be downloaded at <http://www.nerc.com/~filez/tadstf.html>. The five form categories are listed [below on the next page](#).

## **Appendix 1: Administrative Forms with Transmission Owner Information**

- 1.1 Non-Reporting Transmission Owner Statement
- 1.2 Reporting Transmission Owner Information

## **Appendix 2: Forms for ~~Tie Lines & Jointly-Owned~~ Facilities**

- 2.1 ~~Tie Lines and~~ Jointly-Owned AC and DC Circuits
- 2.2 Jointly-Owned AC/DC Back-to-Back Converters

## **Appendix 3: Forms for Element Inventory and Summary Outage Data**

- 3.1 AC and DC Circuit Inventory Data
- 3.2 Transformer Inventory [Data](#)
- 3.3 AC/DC Back-to-Back Converter Inventory Data
- 3.4 Summary Automatic Outage Data

## **Appendix 4: Forms for Detailed Element Automatic Outage Data**

- 4.1 AC Circuit Detailed Automatic Outage Data
- 4.2 DC Circuit Detailed Automatic Outage Data
- 4.3 Transformer Detailed Automatic Outage Data
- 4.4 AC/DC Back-to-Back Converter Detailed Automatic Outage Data

## **Appendix 5: Form for Event ID Code Data**

Each data form has a common layout.

1. A TO *without a reporting obligation* must submit Form 1.1. On Form 1.2, which is required for a TO *with a reporting obligation*, one portion requests the Transmission Owner's (TO's) name, its NERC ID number, the name of its Regional Entity (RE), its country, and the calendar reporting year. This information is input once on Form 1.2 and linked to subsequent forms. If a TO owns TADS Elements in different regions and/or different countries, it must complete separate TADS submittals to for each region and country.
2. All forms except Forms 4.1-4.4 have row numbers as well as columns with letters (A, B, etc.) The column letters and sometimes the row numbers are used as references in the instructions. With the exception of Forms 3.1, 3.2, and 3.3., TOs may add additional rows as needed. If the form has row numbers on it and you add rows, the added rows need to be numbered.
3. Many columns have drop-down menus that correspond to defined choices. For example, all Cause Codes are in a drop-down menu and provide the TO the choice among the *defined* Cause Codes only.
4. To keep the form format the same within a form type, certain columns are grayed out and labeled "NA."

Appendix 7 contains examples to assist the TO in completing Forms 3.1-3.3, which contain inventory data. Appendix 8 contains examples to assist the TO in completing Forms 4.1-4.4, which contain detailed Element outage data.

## 1.4 Data Confidentiality

Under NERC’s confidentiality policy (Section 1500 of NERC’s Rules of Procedures), the entity claiming that information is confidential must state the category under which such information qualifies as confidential.

For practicality, we have made judgments that data on certain forms will likely be confidential information because it contains critical energy infrastructure information (CEII), while other information is not confidential. A TO may make its CEII information (per NERC’s classification) non-confidential by requesting, in writing, that NERC treat it as such.

CEII is defined by Federal Energy Regulatory Commission (FERC) rules as follows:<sup>1</sup>

(1) *Critical energy infrastructure information* means specific engineering, vulnerability, or detailed design information about proposed or existing critical infrastructure that:

- (i) Relates details about the production, generation, transportation, transmission, or distribution of energy;
- (ii) Could be useful to a person in planning an attack on critical infrastructure;
- (iii) Is exempt from mandatory disclosure under the Freedom of Information Act, 5 U.S.C. 552; and
- (iv) Does not simply give the general location of the critical infrastructure.

(2) *Critical infrastructure* means existing and proposed systems and assets, whether physical or virtual, the incapacity or destruction of which would negatively affect security, economic security, public health or safety, or any combination of those matters.

The table below summarizes our judgments on confidential information for each form:

**Table 1.3**

Form	Default Confidentiality
1.1 Non-Reporting Transmission Owner Statement	Not confidential
1.2 Reporting Transmission Owner Information	Not confidential
2.1 <a href="#">Tie Lines and</a> Jointly-Owned AC and DC Circuits	Confidential-CEII
2.2 Jointly-Owned AC/DC Back-to-Back Converters	Confidential-CEII
3.1 AC and DC Circuit Inventory Data	Not confidential
3.2 Transformer Inventory Data	Not confidential
3.3 AC/DC Back-to-Back Converter Inventory Data	Not confidential
3.4 Summary Outage Data	Confidential-CEII
4.1 AC Circuit Detailed Automatic Outage Data	Confidential-CEII
4.2 DC Circuit Detailed Automatic Outage Data	Confidential-CEII
4.3 Transformer Detailed Automatic Outage Data	Confidential-CEII
4.4 AC/DC Back-to-Back Converter Detailed Automatic Outage Data	Confidential-CEII
5 Event ID Code and Event Type Number Data	Confidential-CEII

As described in the Report, regional and NERC annual public performance reports will show *aggregated* confidential information of many TOs. In doing so, no particular TO’s data should be identifiable. However, these reports will not inadvertently release confidential information by the display of regional or NERC information from which a TO’s confidential information could be ascertained. For example, if the TO in a region is the only owner of assets in a particular Voltage Class, the metrics on that data would not be released if the TO’s name and its confidential information could be identified, unless the TO agrees to such a release. If we find that a particular

<sup>1</sup> 18 C.F.R. 388.113(c)(1)-(2)

TO's metrics could be identified in a report, we will ask the TO to voluntarily allow us to report its metrics, while keeping other aspects of its data confidential. By "other aspects of its data" we mean other TADS data such the date of an AC Circuit Sustained Outage or the AC Substations that identify the outaged circuit. Those inputs allow an RE or NERC to determine whether outages of different TOs are a single Event. We will address these requests on a case-by-case basis.

## 1.5 2008 Reporting Schedule

Since the start-up data collection year will be 2008, we developed a timetable that would attempt to catch any fundamental design or implementation issues early rather than wait until year-end. Since data review and processing may take six-months to complete, identifying 2008 problems in mid-2009 would not allow time to correct these problems for the 2009 data submittal. With that in mind, we will follow the timetable below for 2008 data collection. This timetable includes a two-part submittal of 2008 data with an interim NERC report on first quarter 2008 data. REs will submit a bundled data request to TOs by mid-November of 2007.

**Table 1.5**

<b>Date</b>	<b>Action</b>
Late October 2007	NERC will ask Regional Entities to request TADS data from Transmission Owners in their region. The reason NERC is going through the regions (as explained in Section 5.3.3 of the Report), is that regions may elect to request additional data. They will send each TO a bundled data request covering both TADS data and regional-specific data.
Mid-November 2007	Regions will submit their bundled data request to TOs. Certain TADS data is required to be submitted in 2007 to determine which TOs will be not reporting TADS data and, for reporting TOs, who is responsible for reporting outages for <del>tie lines and</del> jointly-owned facilities. TOs who do not own any TADS assets will be required to submit Form 1.1 to REs. TOs who own TADS assets will be required to submit Form 1.2, and, if applicable, Forms 2.1 and 2.2 that address tie lines and jointly-owned facilities, to REs.
January 15, 2008	REs ensure that all <del>tie lines and</del> jointly-owned facilities have a single TO with reporting responsibility.
May 30, 2008	TOs submit data to REs for the first quarter ending March 31. This includes inventory data as well as outage data, as well as resubmission of Form 1.2, and, if applicable, Forms 2.1, and 2.2.
July 15, 2008	REs submit data to NERC after performing an initial data review.
September 26, 2008	NERC completes an interim report on the results, after performing its data checks.
March 1, 2009	TOs resubmit all 2008 data to REs. (This resubmission will replace the first quarter data submitted by May 30, 2008)
Late June, 2009	NERC completes a final 2008 report on the results, after performing its data checks.

For the special first quarter 2008 submittal, minor changes will be made to adapt the data input form. The reporting year will be "2008Q1." On forms that use the term "year" or "annual," those forms will be modified and the word "Q1" will be substituted. The only input data that requires different treatment is the inventory data on Forms 3.1, 3.2, and 3.3 for TOs who either add or remove Elements in the first quarter of 2008. Appendix 7 illustrates how to make this calculation

for an annual submittal. For the special first quarter submittal, the same example applies, except the “year” in Appendix 7 is the first quarter in 2008. It contains 91 days or 2,284 hrs.

### 1.5.1. TADS Data Entry and Analysis Software

REs are the point of contact for TADS data submittals. However, NERC ~~is in the process of completing~~ has completed a request for proposals (RFP) for the development of a NERC TADS software data system to support several processes, including:

- Data entry
- Data error checking
- Data management
- Data analysis and reporting

The availability of this system may impact the logistics of the data submittal process selected by an RE. We expect ~~to issue the RFP in late October, with the expectation~~ that the TADS software system will be available ~~offor~~ receiving automatic outage data by mid-March 2008. Present data inputs use spreadsheets which we recognize are an inefficient way to gather data. ~~Our RFP will require a~~ The TADS software Web-based system ~~that~~ will allow data to be input directly or uploaded in a bulk mode. While the data entry process will be left up to the each RE, two possibilities are described below.

- a. Some REs may not be collecting additional data beyond what TADS is requiring. For these regions, they may allow their TOs to directly input their data into the NERC system. By doing so, they will not need to develop a separate data entry system. Through the NERC system, REs will have access to the data for TOs within their region so that they can perform data review.
- b. Other REs that are collecting additional data may request that the TADS data be input to them along with their additional data. Ultimately, they will need to get the TADS data into the NERC system.

## 1.6 TADS Training

~~We are planning three~~ Three training sessions are planned to familiarize TOs with the new reporting requirements. These sessions will be held from November 2007 through February 2008. Training material will be posted and updated when available.

## 1.7 TADS Help

Assistance in completing the forms is available. The following process will be used:

1. Initial questions should be directed to NERC by writing an e-mail to [tads@nerc.net](mailto:tads@nerc.net). The question will be answered as soon as possible. Written questions are encouraged so that NERC staff can log questions and responses.
2. Particular questions may require phone support. For phone support, call NERC at (609) 452-8060 and ask the operator for a TADS coordinator. The TADS coordinator will document his/her response to the person asking the question in an e-mail.

This process is intended to ensure consistency in responses to questions, and therefore data consistency.

## 1.8 Administrative Forms with Transmission Owner Information

### 1.8.1. Form 1.1 Non-Reporting Transmission Owner Statement

Form 1.1 is for TOs who do not own any TADS Elements as of date they submit it. It will be submitted in the November/December time frame of the year prior to the reporting year. If a Transmission Owner owns no TADS Elements as of its submission date, it provides the contact information of the person completing the form on behalf of the TO who is attesting to that fact.

Should the TO add any TADS elements after this date, the TO will need to complete Form 1.2 when it is next required to be submitted. Otherwise, Form 1.1 must be resubmitted again in the November/December time frame of the next reporting year.

### 1.8.2. Form 1.2 Reporting Transmission Owner Information

Form 1.2 asks for three types of TO information.

1. It requests the business contact information for the primary and back-up TADS contact person for the Transmission Owner.
2. It contains a list to confirm which forms were filed and which forms were not filed. ~~For forms not filed, The list has drop-down menus for “Submission Status” and “Reason Not Submitted” for the TO is asked~~ to explain which forms were submitted and if not submitted, why they were not ~~filed~~ submitted (e.g., TO has none of the facilities reported on the form, the TO had no outages, etc.). This ensures that inadvertent form omissions are corrected prior to submittal. For this reason, Form 1.2 is submitted *twice* during each reporting cycle:<sup>2</sup>
  - a. In November/December time frame of the year prior to the reporting year.
  - b. At the end of the reporting cycle with all other forms.
3. Finally, it lists the NERC default confidentiality status of TO data on each form.

## 2. Forms for ~~Tie lines and~~ Jointly-Owned Facilities

These forms are used to ensure that *one* TO takes on the TADS reporting responsibility for jointly-owned facilities, ~~(including tie lines. Tie lines that the TO has an if jointly-owned).~~ If a TO has less than 100% ownership interest in such facilities, each TO must be entered, even if they are 100% owned enter this facility on Form 2.1 or 2.2. These multiple entries should be coordinated by a the TOs involved. The coordinated entries should indicate which single TO will take reporting responsibility for Forms 3, 4 & 5. This will avoid duplication of outage and inventory reporting, and the other TOs who are joint-owners must be aware that they should not report to TADS on that facility. In addition to the names of all joint owners, their registered NERC ID (or NERC assigned pseudo ID of the designated reporting representative) is also ~~requested~~ required to be entered. The name of each Transmission Owner on the NERC Compliance Registry ~~as well as~~ and its NERC ID is available at <http://www.nerc.com/~org/>. Pseudo NERC IDs have been assigned for various purposes. A document entitled NERC ID Exceptions for TADS is posted at http://www.nerc.com/~filez/tadstf.html explains the TOs that have been assigned pseudo NERC IDs and why they were assigned.

<sup>2</sup> A third submittal is required in 2008 for the first quarter data.

If a TO owns 100% of a facility, the reporting responsibility of that facility belongs to the TO. Do not enter the facility on Forms 2.1 or 2.2. For 100% owned tie lines, communication among the TOs who own the AC Substations that bound the circuit is expected for the purpose of identifying data related to the cause of outages which the reporting TO must supply.

These forms are submitted *twice* for each reporting cycle:<sup>3</sup>

1. In November/December time frame of the year prior to the reporting year.
2. At the end of the reporting cycle with all other forms.

The second submission reflects any additions to facilities that are covered by these forms.

## 2.1 Form 2.1 ~~Tie Lines and~~ Jointly-Owned AC and DC Circuits

The characteristics of each jointly-owned tie line or other jointly-owned facility circuits are input on this form (one facility circuit per row). ~~This form requires tie lines that the TO has an ownership interest~~As discussed in ~~be entered, even if they are 100% owned by a single TO. We~~Section 2, we expect TOs to mutually agree on who should report ~~these facilities~~outage or inventory information (on Forms 3, 4 or 5) of the jointly-owned facility information for TADS and which other owners should not report. Do not enter ~~tie lines~~circuits that you do not own.

The term “tie line” is not defined. Tie lines for TADS purposes are those AC Circuits (or DC Circuits) that are Elements which connect the AC Substations (or AC/DC Terminals) of two Transmission Owners on the with a NERC Compliance Registry ID, including a pseudo NERC ID.

**Table 2.1**

Column	Form 2.1 Descriptor
None	Questions 1 and 2 in the fields above columns D through J ask whether there were any additions <del>tie lines or</del> of jointly-owned circuits during the reporting year and if so, whether those changes were incorporated into the response. These questions apply to the second submittal only, and appropriate “NA” responses are provided as an answer associated with a first submittal.
A	The type of circuit (AC or DC), input from a drop-down menu, describes the main characteristic of the facility.
B	From – Substation or Terminal Name. The alphanumeric code designating one of the Substation Names for an AC Circuit or one of the Terminal Names for a DC Circuit.
C	To – Substation or Terminal Name. The alphanumeric code designating a second Substation Name for an AC Circuit or a second Terminal Name for a DC Circuit.
D	<del>The Voltage Class of the facility, input from a drop down menu. Note that five Voltage Classes are in the drop down menu. The menu selection is presently not interactive with the selection of “AC” or “DC” in column A. However, the database will put AC inputs into one of four AC Voltage Classes.</del> To – Substation or Terminal Name. The alphanumeric code designating a third Substation Name for an AC Circuit or a third Terminal Name for a DC Circuit.
E	<del>Underground or Overhead. This</del> The Voltage Class of the facility characteristic is, input from a drop-down menu. <del>See the definition of Overhead and Underground in Appendix 6, Section A.</del> Note that five Voltage Classes are in the drop down menu. The menu selection is presently not interactive with the selection of “AC” or “DC” in column A. However, the database will put AC inputs into one of four AC Voltage Classes.
F-G	The company name of the TO with TADS reporting responsibility and its NERC ID number <del>Underground or Overhead. This facility characteristic is input from a</del>

<sup>3</sup> A third submittal is required in 2008 for the first quarter data.

	<a href="#">drop-down menu. See the definition of Overhead and Underground in Appendix 6, Section A.</a>
<a href="#">G-H</a>	The <a href="#">NERC ID number and name of the TO with TADS reporting TO's Element Identifier responsibility.</a>
<a href="#">I-P</a>	<del>The company name(s) and NERC ID numbers of the TOs that have an ownership interest in the Element. Up to four owner names are provided. One of those names to be the TO with TADS reporting responsibility input in column F. The reporting TO's Element Identifier (optional).</del>
<a href="#">J-Q</a>	The NERC ID numbers and name of the TOs that have an ownership interest in the Element. Up to four owner names are provided. One of the TOs must be the TO with TADS reporting responsibility input in columns G-H

## 2.2 Form 2.2 Jointly-Owned AC/DC Back-to-Back Converter

The characteristics of each jointly-owned AC/DC Back-to-Back Converter are input on this form (one facility per row). This form is *not required to be used* for AC/DC Back-to-Back Converters owned 100% by a single TO.

**Table 2.2**

Column	Form 2.2 Descriptor
None	Questions 1 and 2 in the fields above columns D-J ask whether there were any additions of jointly-owned AC/DC BTB Converters during the reporting year and if so, whether those changes were incorporated into the response. These questions apply to the second submittal only, and appropriate "NA" responses are provided as an answer associated with a first submittal.
A	Converter Station Name. The alphanumeric code designating the converters name.
B	<b>NOT APPLICABLE</b>
C	The AC Circuit Voltage Class, input from a drop-down menu, on one side of the converter
D	The AC Circuit Voltage Class, input from a drop-down menu, on the other side of the converter
<a href="#">E-F</a>	<b>NOT APPLICABLE</b>
<a href="#">F-G-H</a>	The <del>company</del> <a href="#">NERC ID number and name of the TO with TADS reporting responsibility and its NERC ID number.</a>
<a href="#">H-I</a>	The reporting TO's Element Identifier
<a href="#">I-P-J-Q</a>	The <del>company name(s) and</del> <a href="#">NERC ID numbers and names</a> of the TOs that are joint owners of the facility. Up to four owner names are provided. One of <del>those names</del> <a href="#">to the TOs must</a> be the TO with TADS reporting responsibility input in column <a href="#">F-G-H.</a>

## 3. Forms for Element Inventory and Summary Outage Data

### 3.1 Form 3.1 AC and DC inventory Data

Form 3.1 is a two-part form:

1. The top half of the form has inventory data for AC and DC Circuits  $\geq 200$  kV.
1. The bottom half contains Multi-Circuit Structure Mile data for AC Circuits only. [If a line section contains two or more common structures which form one or more multi-circuit spans, the total span length can be measured and the associated mileage should be reported in the Multi-Circuit Structure Mile data. If multiple circuits are connected to only one common structure, that structure should be ignored for outage and inventory mileage purposes.](#)

2. All DC Circuits are assumed to have two circuits per structure; therefore, for each DC Circuit Voltage Class, the Multi-Circuit Structure Miles is one-half of the total Circuit Miles.

**Table 3.1**

Column	Form 3.1 Descriptor
A	Rows 1-4: AC Overhead Circuit Data by Voltage Class
A	Rows 5-8: AC Underground Circuit Data by Voltage Class
A	Rows 9-13: DC Overhead Circuit Data by Voltage Class
A	Rows 14-18: DC Underground Circuit Data by Voltage Class
<i>See Appendix 6, Section A, for definitions of “Overhead” and “Underground”</i>	
<b>AC and DC Circuit Inventory Data</b>	
<i>Appendix 7 has an example that illustrates the data requirements for columns B-K for AC and DC Circuits.</i> Appendix 7 illustrates how to make this calculation for an annual submittal. For the special first quarter 2008 submittal, the same example applies, except the “year” in Appendix 7 is the first quarter in 2008. It contains 91 days or 2,284 hrs.	
B	The number of circuits that are installed and “in-service” at the end of the reporting year in each Voltage Class which are reported by the TO. <b>This includes circuits that are tie-lines or jointly-owned circuits that are reported by the TO.</b> The term “in-service” refers to the accounting state of the circuit, not its operational state. If you have no circuits in a particular Voltage Class, an “NA” is the default entry in columns B through K.
C	The number of Circuit Miles associated with the circuits in column B.
D	The number of circuits that were added during the year. These could be new circuits or a circuit that, after reconfiguring, defines a new circuit. For example, if an AC Circuit defined by two breakers that has a tap added with another breaker becomes a three-terminal instead of a two-terminal circuit. The three-terminal circuit is an addition, and the previous two-terminal circuit must be removed. The removed circuit will be contained in column H.
E	The equivalent number of circuits added.
F	The number of Circuit Miles added. These Circuit Miles are associated with the number of circuits in column D.
G	The equivalent number of Circuit Miles added.
H	The number of circuits that were removed during the year. In the example discussed for column D, the two-terminal circuit that became a three-terminal circuit would be a circuit that is removed and therefore contained in column H. Note: column H is not used in the calculation in column L.
I	The equivalent number of circuits removed.
J	The number of Circuit Miles removed. These Circuit Miles are associated with the number of circuits in column H.
K	The equivalent number of Circuit Miles removed.
L	This is a calculated value for the equivalent annual number of circuits for the reporting year. Note that column H is not used; it is requested as a “sanity check” for column I.
M	This is a calculated value for the equivalent annual number of Circuit Miles for the reporting year. Note that column J is not used; it is requested as a “sanity check” for column K.
<b>AC Multi-Circuit Structure Miles Inventory Data</b>	
<i>Appendix 7 has an example that illustrates the data requirements for columns B-K for Multi-Circuit Structure Miles.</i>	
<ol style="list-style-type: none"> <li>Note: multi-circuit structures that are occupied by <i>only one circuit</i> do not contribute to the tabulation of Multi-Circuit Structure Miles.</li> <li>Appendix 7 illustrates how to make this calculation for an annual submittal. For the special first quarter 2008 submittal, the same example applies, except the “year” in Appendix 7 is the first quarter in 2008. It contains 91 days or 2,284 hrs.</li> </ol>	
A	Rows 19-23 AC multi-circuit structure Voltage Class. Note the “Mixed Voltage” class. This class applies to multi-circuit structures that have two TADS AC Circuits of different voltages (e.g., 230 kV and 345 kV) on the same structure. A structure

	is not a considered a multi-circuit structure for TADS reporting unless in has two or more AC Circuits, each circuit with a voltage $\geq 200$ kV. Therefore, a structure with a 230 kV and a 138 kV AC Circuit does not contribute to the tabulation of Multi-Circuit Structure Miles.
B	<b>NOT APPLICABLE</b>
C	The number of Multi-Circuit Structure Miles in the Voltage Class associated with AC Circuits reported by the TO at the end of the reporting year. <b>This includes AC Circuits that are tie lines or jointly-owned circuits that are reported by the TO.</b> If you have no multi-circuit structures in a particular Voltage Class, an “NA” is the default entry in columns C, F, G, J, and K.
D-E	<b>NOT APPLICABLE</b>
F	The number of Multi-Circuit Structure Miles added in the Voltage Class associated with AC Circuits reported by the TO.
G	The equivalent number of Multi-Circuit Structure Miles added.
H-I	<b>NOT APPLICABLE</b>
J	The number of Multi-Circuit Structure Miles removed in the Voltage Class associated with AC Circuits reported by the TO.
K	The equivalent number of Multi-Circuit Structure Miles removed.
L	<b>NOT APPLICABLE</b>
M	This is a calculated value for the equivalent annual number of Multi-Circuit Structure Miles for the reporting year. Note that column J is not used; it is requested as a “sanity check” for column K.
N-Q	<b>NOT APPLICABLE</b>
<i>For common structures that carry circuits owned by different TOs, we expect the TOs to coordinate with each other on their reporting of Multi-Circuit Structure Miles so that no double counting takes place. As an example, suppose two circuits owned by different TOs occupy common structures for 10 miles. For this section, the combined number of Multi-Circuit Structure Miles reported by the TOs should not exceed 10. We do not want each TO to report 10 miles since that would double count the miles for the region.</i>	
A-H	Rows 24-25 ask whether the coordination requested above has taken place among TOs that own separate circuits on common structures.

### 3.2 Form 3.2 Transformer Inventory Data

The inventory data for Transformer is input on this form.

**Table 3.2**

Column	Form 3.2 Descriptor
A	Rows 1-4: The Voltage Class of the reported Transformers data, based upon all Transformer’s high-side voltage. While high-side voltages are reported on this form, each Transformer must have a low-side voltage $\geq 200$ kV.
<b>Transformer Inventory Data</b>	
<i>Appendix 7 has an example that illustrates the data requirements for the equivalent number of circuits. The equivalent number of Transformers follows a similar methodology.</i> Appendix 7 illustrates how to make this calculation for an annual submittal. For the special first quarter 2008 submittal, the same example applies, except the “year” in Appendix 7 is the first quarter in 2008. It contains 91 days or 2,284 hrs.	
B	The number of Transformers that are installed and “in-service” at the end of the reporting year of in each Voltage Class. Do not include spares. The term “in-service” refers to the accounting state of the Transformer, not its operational state. If you have no Transformers in a particular Voltage Class, an “NA” is the default entry in columns B through F.
C	The number of Transformers that were added during the year. If a Transformer merely replaces a “like” Transformer (same high-side and low-side voltages) at the same location, this does not count as an addition or a removal. If the replacement is not a “like” Transformer, an addition should be counted as well as a removal.

D	The equivalent number of Transformers added.
E	The number of Transformers that were removed. If a Transformer merely replaces a “like” Transformer (same high-side and low-side voltages) at the same location, this does not count as an addition or a removal. If the replacement is not a “like” Transformer, an addition should be counted as well as a removal.
F	The equivalent number of Transformers removed.
G	This is a calculated value for the equivalent annual number of Transformers for the reporting year. Note that column E is not used; it is requested as a “sanity check” for column F.

### 3.3 Form 3.3 AC/DC BTB Converter Inventory Data

The inventory data for AC/DC BTB Converters is input on this form.

**Table 3.3**

Column	Form 3.3 Descriptor
A	Rows 1-4: The Voltage Class of the reported AC/DC BTB Converters is the highest AC terminal voltage in the AC/DC BTB Converter. This is a phase-to-phase voltage.
<b>AC/DC BTB Converter Inventory Data</b>	
<i>Appendix 7 has an example that illustrates the data requirements for the equivalent number of circuits. The equivalent number of AC/DC BTB Converters follows a similar methodology.</i> Appendix 7 illustrates how to make this calculation for an annual submittal. For the special first quarter 2008 submittal, the same example applies, except the “year” in Appendix 7 is the first quarter in 2008. It contains 91 days or 2,284 hrs.	
B	The number of AC/DC BTB Converters that are installed and “in-service” at the end of the reporting year of in each Voltage Class. <b>This includes jointly-owned AC/DC BTB Converters that are reported by the TO.</b> The term “in-service” refers to the accounting state of the AC/DC BTB Converter, not its operational state. If you have no AC/DC BTB Converters in a particular Voltage Class, an “NA” is the default entry in columns B through F.
C	The number of AC/DC BTB Converters that were added during the year.
D	The equivalent number of AC/DC BTB Converters added.
E	The number of AC/DC BTB Converters that were removed.
F	The equivalent number of AC/DC BTB Converters removed.
G	This is a calculated value for the equivalent annual number of AC/DC BTB Converters for the reporting year. Note that column E is not used; it is requested as a “sanity check” for column F.

### 3.4 Form 3.4 Summary Automatic Outage Data

This form contains summary outage data for each of the TADS Elements. Therefore, its description will use the term “Element” to mean a defined TADS Element.

**Table 3.4**

Column	Form 3.4 Descriptor
A	The Voltage Class of the reported Element. These are the same Voltage Classes used for Elements on the inventory data forms (Forms 3.1, 3.2, and 3.3).
B	The total number of Sustained Outages for all Elements for the calendar year.
C	The total number of Momentary Outages for all Elements for the calendar year.
<b>Columns B and C are a Self-Checks:</b> These totals in columns B and C can be derived from the detailed Automatic Outage data reported on Form 4.1 (AC Circuits), Form 4.1 (DC Circuits), Form 4.3 (Transformers), and Form 4.4 (AC/DC Back-To-Back Converters).	
D	Number of Elements with zero outages. This number only includes Elements that are in service at the <i>end of the year</i> (or the end of the quarter for special first quarter 2008 submittal) because the percentage calculation in column E is based upon end-of-year (or quarter) inventory. One way to calculate the number of Elements with zero outages is as follows: <ol style="list-style-type: none"> <li>1. First find which Elements had <i>one or more</i> outages by using the data of the detailed Automatic Outage data forms (Forms 4.1-4.4). The optional TO Element Identifier would need to be used to identify the Element itself.</li> <li>2. From the list of Elements developed in step 1 above, <i>subtract</i> the Elements that were removed from service during the year. The result is the number of Elements with one or more outages that were in service at the end of the year.</li> <li>3. For the final calculation, subtract the result from step 2 from the total number of Elements in service at the end of the year (see column B on the inventory data forms (Forms 3.1, 3.2, or 3.3, as applicable) for this value). The result is the total number of Elements that are in service at the end of the year which had zero outages.</li> </ol>
E	The percentage of Elements with zero outages is a calculated value. It takes the value in D and divides it by the value in column B from the inventory data forms, converting the result into a percentage.

#### 4. Forms for Detailed Automatic Outage Data

These forms contain data for *each* and *every* Automatic Outage of an Element, both Sustained and Momentary. This form has does not have row numbers. Since each line represents an outage and each outage has a unique Outage ID Code, this code is used to identify outage entry.

The first several columns (A-I) contain information that generally describes the Element that was outaged. The single exception is the Event ID Code. The remaining columns (J-P) describe the outage itself. Since there is so much similarity between the columns, all descriptors will be provided once, using the generic term of “Element” instead of AC Circuit, Transformer, etc.

Appendix 8 provides many examples illustrating the completion of the various Form 4 series.

**Table 4.1-4.4**

<b>Data for Elements That Had an Automatic Outage</b>	
Column	Forms 4.1-4.4 Descriptor
A	The Outage ID Code assigned to the outage. This is assigned by the TO. See Appendix 6, Section B for the definition of Event ID Code.
B	The Event ID Code associated with the outage. This is assigned by the TO on Form 5. See Appendix 6, Section B for the definition of Event ID Code. The Event ID Code must be appended with the reporting year (e.g., WXY-2008).
C	The Element’s Voltage Class. This is consistent to the Voltage Class definitions used for Inventory Data on Forms 3.1-3.3. AC Circuit= phase-to-phase      Transformer=high-side voltage DC Circuit= phase-to-return      AC/DC BTB Converter= highest AC terminal voltage (phase-to-phase)

D-F	Data that provides a description of the physical location of the Element. AC Circuit= AC Substation Names (3 max)      Transformer=AC Substation Name DC Circuit= AC/DC Terminal Names (3 max)      AC/DC BTB Converter= Its name
G	The TO Element Identifier is an optional, but recommended, alphanumeric field that has the TO's internal identifier of the Element. This could be a circuit or transformer number or other identifier recognized by the TO.
H	This column is only for AC or DC Circuits and identifies whether the outaged Element in an Overhead or Underground Circuit.
I	The AC Multi-Owner Common Structure Flag. This flag only applies to Form 4.1 and is explained on footnote 3 as well as Appendix 6, Section B where the term is fully defined.
The descriptions that follow use defined terms that the TO should become familiar with. They will not be repeated here. Most data fields have drop-down menus. They each describe various facets of the outage.	
J	The Fault Type <b>(if any) for each circuit Outage</b> , input from a drop-down menu.
K	The Outage Initiation Code, input from a drop-down menu.
L	The Outage Start Time, in Universal Coordinated Time (UTC), <i>not</i> local time. The use of UTC time will allow related outaged occurring on Elements reported by different Transmission Owners to be linked. See instructions Section 4.1 below for outages that continue beyond the end of the reporting year.
M	The Outage Duration expressed as hours and minutes. Momentary Outages will enter a "0" (zero) in this field since we round to the nearest minute. A zero entry in column M tells the reviewer that the outage was Momentary. See instructions in Section 4.1 below for outages that continue beyond the end of the reporting year.
N	The Initiating Cause Code, input from a drop-down menu. All Momentary Outages must supply this code, and the "Unavailable" Cause Code cannot be used for Momentary Outages. Sustained Outages may use the "Unavailable" code in 2008 only for either the Initiating Cause Code or the Sustained Cause Code, but not both. If the TO has the ability to capture Initiating <i>and</i> Sustained Cause Codes, the "Unavailable" code is not be used at all. (Note: the spreadsheet drop-down menus do not have this conditional features built in.)
O	The Sustained Cause Code, input from a drop-down menu. This only applies to Sustained Outages. Momentary Outages enter "NA-Momentary."
P	The Outage Mode, input from a drop-down menu.

## 4.1 Outages That Continue Beyond the End of the Year

If an outage begins in a reporting calendar year and continues beyond the end of the year (December 31) or beyond the end of the quarter (March 31) for the special first quarter submittal in 2008, the calculation of a total Outage Duration is not possible. In this case, the following process will be observed.

1. Two separate Outage Durations will be input.
  - a. For the reporting year when the outage started, the TO inputs the Outage Start Time and a "9999" for the Outage Duration. The software will calculate and Outage Duration from the Outage Start Time until the end of the reporting year (or the first quarter for the special first quarter submittal in 2008). A "9999" in the Outage Duration indicates that the outage continues beyond the reporting period.
  - b. For the next reporting year, the *same* Event ID Code and *same* Outage ID Code will be entered for the outage with an Outage Start Time equal to "9999." This combination indicates that the outaged Element started its outage in the previous reporting year and is returning to service in the current reporting year. The TO will input a duration that is calculated as if the outage commenced on January 1, 00:00 UTC of the reporting year.

2. For purposes of calculating metrics, the metrics in the first reporting year (or the first quarter if applicable) will reflect the outage in that year (or quarter) for frequency calculations. However, the Outage Duration will be split between reporting years as described above, and any outages with Event ID Codes from the prior year will *not* be counted towards the frequency calculation in the second year.
3. The procedure above can be used in the rare event that an outage spans more than two reporting years. In this case, step 1.b. above would be modified and a “9999” would be entered into the Outage Duration field instead of being calculated by the TO. The software would assign an Outage Duration equal to the duration of the year.

## 5. Form for Event ID Code and Event Type Number Data

TO's assign their own Event ID Codes and associated Event Type Numbers. An Event is a transmission incident that results in the Sustained or Momentary Outages of one or more Elements. The table below describes the data collected for the Event ID Code:

**Table 5**

Column	Form 5 Descriptor
A	The Event ID Code associated with one or more outages. This is assigned by the TO. See Appendix 6, Section B for the definition of Event and Event ID Code. The Event ID Code must be appended with the reporting year (e.g., WXY-2008). For the special first quarter submittal, use "2008" and not "2008Q1." That way the Event ID Codes can be used for the 2008 annual submittal as well.
B	The Event Type No. This is a descriptor of the Event. The table on Form 5 shows the permitted entries, which are in a drop-down menu. <ul style="list-style-type: none"> <li>Note that if Event Type No. 10 or 20 is selected, the Outage Mode on Forms 4.1, 4.2, or 4.3 (column P) must be "Single Mode Outage."</li> <li>Outages of an AC/DC Back-to-Back Converter (Form 4.4) must select Event Type No. 50.</li> <li><a href="#">Table 5.1 below shows the possible Event Type Numbers based upon several criteria</a></li> </ul>
C	<u>Optional input:</u> If Event Type 50 (Other) is selected for column B, the TO, at its option, may describe the Event.
D	This field asks whether a disturbance report was filed that was associated with the Event, with different answers contained in a drop-down menu. Year-to-date public (i.e., non-confidential) data of all disturbance report filings are located at <a href="http://www.nerc.com/~filez/dawg-disturbancereports.html">http://www.nerc.com/~filez/dawg-disturbancereports.html</a> .

**Table 5.1**

Element	Outage Mode	# of Element Outages with same Event ID	Normal Clearing?	Common Structure?	= Event Type No.
AC Circuit or Transformer	<b>Single</b>	<b>1 TADS Element</b>	<b>Yes</b>	N/A	<b>10</b>
DC Circuit	<b>Single</b>	<b>1 TADS Element</b>	<b>Yes</b>	N/A	<b>20</b>
AC Circuit	Any Other than Single	<b>2 TADS Elements</b>	<b>Yes</b>	<b>Yes*</b>	<b>possible 30**</b>
DC Circuit	Any Other than Single	<b>2 TADS Elements</b>	<b>Yes</b>	<b>Yes*</b>	<b>possible 40**</b>
AC Circuit or Transformer	<b>Any Mode</b>	<b>&gt;= 1 TADS Element</b>	<b>No</b>	N/A	<b>50</b>
DC Circuit	<b>Any Mode</b>	<b>&gt;= 1 TADS Element</b>	<b>No</b>	N/A	<b>50</b>
AC Circuit or Transformer	Any Other than Single	<b>2 TADS Elements</b>	<b>Yes</b>	<b>No*</b>	<b>50</b>
DC Circuit	Any Other than Single	<b>2 TADS Elements</b>	<b>Yes</b>	<b>No*</b>	<b>50</b>
AC Circuit	Any Other than Single	<b>2 TADS Elements</b>	<b>Yes</b>	<b>Yes*</b>	<b>possible 50**</b>
DC Circuit	Any Other than Single	<b>2 TADS Elements</b>	<b>Yes</b>	<b>Yes*</b>	<b>possible 50**</b>
AC Circuit, Transformer	Any Other than Single	<b>&gt;2 TADS Elements</b>	N/A	N/A	<b>50</b>
DC Circuit	Any Other than Single	<b>&gt;2 TADS Elements</b>	N/A	N/A	<b>50</b>
AC/DC Back-to-Back Converter	<b>Any Mode</b>	<b>&gt;= 1 TADS Element</b>	N/A	N/A	<b>50</b>
Notes:	* Yes = two or more common structures.		No = one or zero common structures.		
	** TO to determine based on available information.				

## Appendix 1 Administrative Forms with Transmission Owner Information

### 1.1. Non-Reporting Transmission Owner Statement

<b>Form 1.1 Non-Reporting Transmission Owner Statement</b>	
Row No.	NERC ID: <a href="#">NCR00000</a>
1	Transmission Owner Name: <a href="#">ABC Power &amp; Light Co.</a>
2	Regional Entity Name: <a href="#">TRE</a>
3	Country: <a href="#">US</a>
4	Reporting Year: <a href="#">2008</a>
5	
6	As of date below, the Transmission Owner named above affirms that it
7	<b>does not</b> own any transmission assets as defined below:
8	<b>1. AC Circuits <math>\geq</math> 200 kV (Overhead and Underground)</b>
9	<b>2. Transformers with <math>\geq</math> 200 kV low-side voltage</b>
10	<b>3. AC/DC Back-to-Back Converters with <math>\geq</math> 200 kV AC voltage, both sides</b>
11	<b>4. DC Circuits with <math>\geq</math> +/-200 kV DC voltage</b>
12	
13	The definitions of the terms used above are defined in the NERC TADS
14	<i>Data Reporting Instruction Manual</i> posted at
15	<a href="http://www.nerc.com/~filez/tadstf.html">http://www.nerc.com/~filez/tadstf.html</a> .
16	
17	On behalf of the Transmission Owner named above, this statement is submitted by:
18	Name
19	Title
20	Company
21	Mailing Address
22	
23	
24	
25	E-mail address
26	Telephone (office)
27	Telephone (mobile)
28	Date

## 1.2. Reporting Transmission Owner Information

Form No.	Short Form Name	Submission Status	Reason Not Submitted	NERC Default Confidentiality Status*
1.2	TO Info	Submitted	<b>Must be submitted</b>	Data is <b>not</b> Confidential.
2.1	Tie Lines and Joint AC/DC Ckts	Submitted	NA; form was submitted	Confidential - Critical Energy Infrastructure Information
2.2	Joint AC/DC BTB Converters	Not Submitted	No data of this type	Confidential - Critical Energy Infrastructure Information
3.1	AC/DC Ckt. Inven.	Submitted	No Elements of this type	Data is <b>not</b> Confidential.
3.2	Transformer Inven.	Submitted	NA; form was submitted	Data is <b>not</b> Confidential.
3.3	AC/DC BTB Con. Inven.	Not Submitted	No Elements of this type	Data is <b>not</b> Confidential.
3.4	Summary Auto. Outage Data	Submitted	NA; form was submitted	Confidential - Critical Energy Infrastructure Information
4.1	AC Circuit Outages	Submitted	N/A; form was submitted	Confidential - Critical Energy Infrastructure Information
4.2	DC Circuit Outages	Not Submitted	No Elements of this type	Confidential - Critical Energy Infrastructure Information
4.3	Transformer Outages	Not Submitted	No Outages	Confidential - Critical Energy Infrastructure Information
4.4	AC/DC BTB Con. Outages	Not Submitted	No Elements of this type	Confidential - Critical Energy Infrastructure Information
5	Event ID Codes	Submitted	NA; form was submitted	Confidential - Critical Energy Infrastructure Information
				<b>* If the TO wants to change NERC's confidentiality classification for any data, please explain in a separate letter to NERC.</b>

Form No.	Short Form Name	Submission Status	Reason Not Submitted	NERC Default Confidentiality Status*
1.2	TO Info	Submitted	<b>Must be submitted</b>	Data is <b>not</b> Confidential.
2.1	Tie Lines and Joint AC/DC Ckts	Submitted	NA; form was submitted	Confidential - Critical Energy Infrastructure Information
2.2	Joint AC/DC BTB Converters	Not Submitted	No data of this type	Confidential - Critical Energy Infrastructure Information
3.1	AC/DC Ckt. Inven.	Submitted	No Elements of this type	Data is <b>not</b> Confidential.
3.2	Transformer Inven.	Submitted	NA; form was submitted	Data is <b>not</b> Confidential.
3.3	AC/DC BTB Con. Inven.	Not Submitted	No Elements of this type	Data is <b>not</b> Confidential.
3.4	Summary Auto. Outage Data	Submitted	NA; form was submitted	Confidential - Critical Energy Infrastructure Information
4.1	AC Circuit Outages	Submitted	N/A; form was submitted	Confidential - Critical Energy Infrastructure Information
4.2	DC Circuit Outages	Not Submitted	No Elements of this type	Confidential - Critical Energy Infrastructure Information
4.3	Transformer Outages	Not Submitted	No Outages	Confidential - Critical Energy Infrastructure Information
4.4	AC/DC BTB Con. Outages	Not Submitted	No Elements of this type	Confidential - Critical Energy Infrastructure Information
5	Event ID Codes	Submitted	NA; form was submitted	Confidential - Critical Energy Infrastructure Information
				<b>* If the TO wants to change NERC's confidentiality classification for any data, please explain in a separate letter to NERC.</b>

## Appendix 2 Forms for Tie Lines and Jointly-Owned Facilities

### 2.1. Tie Lines and Jointly-Owned AC and DC Circuits

Form 2.1																		
NERC ID: NCR00000										CONFIDENTIAL INFORMATION								
Transmission Owner (TO): ABC Power & Light Co.																		
Regional Entity: TRE [1]										1. Were jointly-owned AC or DC Circuits added during the reporting year?				NA - 1st submittal				
Country: US [1]										2. If the answer to the question above is "yes," does this Form 2.1 reflect the additions?				NA				
Reporting (Calendar) Year: 2008																		
This form lists all the AC Circuits or DC Circuits that are either jointly-owned facilities and which are ≥ 200 kV. One TO must assume reporting responsibility, and that TO is identified in columns G and H. To insure that outage data on these Elements are reported, the TO must list each Element, the joint-owners and the TO that is reporting outage data on the Element.																		
Row No.	Type of Circuit (AC or DC)	Substation/Terminal Name				Voltage Class	Overhead or Underground	Reporting TO's NERC ID	Reporting TO's Name	Reporting TO's Element Identifier (optional)	Names of All Transmission Owners							
		(A)	(B)	(C)	(D)						(E)	(F)	(G)	(H)	(I)	(J)	(K)	(L)
		From	To	To						TO#1 NERC ID	TO#1 Name	TO#2 NERC ID	TO#2 Name	TO#3 NERC ID	TO#3 Name	TO#4 NERC ID	TO#4 Name	
1	AC	Smith	Jones		200-299 kV	OH	NCR00000	ABC P&L	ShJs#1	NRC00001	XYZ Power	NCR00000	ABC P&L					
2																		
3																		
4																		
5																		
6																		
7																		
8																		
<b>Notes:</b>																		
[1] If a TO owns assets in a different NERC Region or in a different country, provide data for each Region and country in a separate workbook.																		

## 2.2. Jointly-Owned AC/DC Back-to-Back Converters

Form 2.2																	
NERC ID: NCR00000		CONFIDENTIAL INFORMATION															
Transmission Owner (TO): ABC Power & Light Co.																	
Regional Entity: TRE		[1]										1. Were jointly-owned AC/DC Back-to-Back Converters added during the reporting year?		NA - 1st submittal			
Country: US		[1]										2. If the answer to the question above is "yes," does this Form 2.2 reflect the additions?		NA			
Reporting (Calendar) Year: 2008																	
<p>This form lists all the <b>AC/DC Back-to-Back Converters</b> that are jointly-owned facilities and which are <math>\geq 200</math> kV AC on both sides. To insure that outage data on these Elements are reported, the TO must list each Element, the name of the joint-owners and the TO that is reporting outage data on the Element. If the Element is 100% owned by one TO, this Form 2.2 is not required.</p>																	
Row No.	(A) Name of AC/DC Back-to-Back Converter Station	(B)	(C) AC Circuit Voltage Class on one side	(D) AC Circuit Voltage Class on second side	(E)	(F)	(G) Reporting TO's NERC ID	(H) TO with TADS Reporting Responsibility	(I) Reporting TO's Element Identifier	Names of Joint Transmission Owners							
										(J) TO#1 NERC ID	(K) TO#1 Name	(L) TO#2 NERC ID	(M) TO#2 Name	(N) TO#3 NERC ID	(O) TO#3 Name	(P) TO#4 NERC ID	(Q) TO#4 Name
1	Garden	NA	200-299 kV	200-299 kV	NA	NA	NRC00001	XYZ Power	Garden	NRC00001	XYZ Power	NCR00000	ABC P&L				
2		NA			NA	NA											
3		NA			NA	NA											
4		NA			NA	NA											
5		NA			NA	NA											
6		NA			NA	NA											
7		NA			NA	NA											
8		NA			NA	NA											
Notes:																	
[1] If a TO owns assets in a different NERC Region or in a different country, provide data for each Region and country in a separate workbook.																	

## Appendix 3 Forms for Element Inventory and Summary Outage Data

### 3.1. AC and DC Circuit Inventory Data

AC and DC Circuit Inventory Data													
Row No.	(A) Voltage Class [2]	(B) No. of Circuits (End-of-Year)	(C) Circuit Miles (End-of-Year)	(D) No. of Circuits Added	(E) Equivalent Annual No. of Circuits Added [3]	(F) No. of Circuit Miles for Circuits Added	(G) Equivalent Annual No. of Circuit Miles for Circuits Added [3]	(H) No. of Circuits Removed	(I) Equivalent Annual No. of Circuits Removed [3]	(J) No. of Circuit Miles for Circuits Removed	(K) Equivalent Annual No. of Circuit Miles for Circuits Removed [3]	(L) CALCULATED Annual Equivalent No. of Circuits = B-D+E+I	(M) CALCULATED Annual Equivalent No. of Circuit Miles = C-F+G+K
1	200-299 kV AC Overhead	83.0	400.0	8.0	6.2	66.0	55.0	3.0	2.1	28.0	21.0	83.3	410.0
2	300-399 kV AC Overhead	NA	NA	NA	NA	NA	NA	NA	NA	NA	NA	NA	NA
3	400-599 kV AC Overhead	NA	NA	NA	NA	NA	NA	NA	NA	NA	NA	NA	NA
4	600-799 kV AC Overhead	NA	NA	NA	NA	NA	NA	NA	NA	NA	NA	NA	NA
5	200-299 kV AC Underground	NA	NA	NA	NA	NA	NA	NA	NA	NA	NA	NA	NA
6	300-399 kV AC Underground	NA	NA	NA	NA	NA	NA	NA	NA	NA	NA	NA	NA
7	400-599 kV AC Underground	NA	NA	NA	NA	NA	NA	NA	NA	NA	NA	NA	NA
8	600-799 kV AC Underground	NA	NA	NA	NA	NA	NA	NA	NA	NA	NA	NA	NA
9	200-299 kV DC Overhead	NA	NA	NA	NA	NA	NA	NA	NA	NA	NA	NA	NA
10	300-399 kV DC Overhead	NA	NA	NA	NA	NA	NA	NA	NA	NA	NA	NA	NA
11	400-599 kV DC Overhead	NA	NA	NA	NA	NA	NA	NA	NA	NA	NA	NA	NA
12	500-599 kV DC Overhead	NA	NA	NA	NA	NA	NA	NA	NA	NA	NA	NA	NA
13	600-799 kV DC Overhead	NA	NA	NA	NA	NA	NA	NA	NA	NA	NA	NA	NA
14	200-299 kV DC Underground	NA	NA	NA	NA	NA	NA	NA	NA	NA	NA	NA	NA
15	300-399 kV DC Underground	NA	NA	NA	NA	NA	NA	NA	NA	NA	NA	NA	NA
16	400-499 kV DC Underground	NA	NA	NA	NA	NA	NA	NA	NA	NA	NA	NA	NA
17	500-599 kV DC Underground	NA	NA	NA	NA	NA	NA	NA	NA	NA	NA	NA	NA
18	600-799 kV DC Underground	NA	NA	NA	NA	NA	NA	NA	NA	NA	NA	NA	NA
AC Multi-Circuit Structure Miles Inventory Data													
	(A) Voltage Class [2]	(B)	(C) Multi-Circuit Structure Miles (End-of-Year)	(D)	(E)	(F) No. of Multi-Circuit Structure Miles for Circuits Added	(G) Equivalent Annual No. of Multi-Circuit Structure Miles for Circuits Added [3]	(H)	(I)	(J) No. of Multi-Circuit Structure Miles for Circuits Removed	(K) Equivalent Annual No. of Multi-Circuit Structure Miles for Circuits Removed [4]	(L)	(M) CALCULATED Annual Equivalent No. of Multi-Circuit Structure Miles = C-F+G+K
19	200-299 kV AC	NA	NA	NA	NA	NA	NA	NA	NA	NA	NA	NA	NA
20	300-399 kV AC	NA	60.0	NA	NA	25.0	14.0	NA	NA	0.0	0.0	NA	49.0
21	400-599 kV AC	NA	NA	NA	NA	NA	NA	NA	NA	NA	NA	NA	NA
22	600-799 kV AC	NA	NA	NA	NA	NA	NA	NA	NA	NA	NA	NA	NA
23	Mixed Voltages [4]	NA	NA	NA	NA	NA	NA	NA	NA	NA	NA	NA	NA
24	Transmission Owner Coordination Questions	1. Do any of the Multi-Circuit Structure Miles contain circuits on the common structures that are owned by you and another Transmission Owner(s)?						No					
25	Transmission Owner Coordination Questions	2. If the answer to question 1 is "yes," have you and the other Transmission Owner(s) coordinated your reporting to insure that no double counting of Multi-Circuit Structure Miles are being reported for the circuits on these structures?						Not applicable					
Notes:													
[1] If a TO owns assets in a different NERC Region or in a different country, provide data for each Region and country in a separate workbook.													
[2] AC Circuit Voltages are phase-to-phase. DC Circuit Voltages are phase-to-return.													
[3] See example in the Data Reporting Instruction Manual, Appendix 7													
[4] Mixed TADS voltages (e.g., 230 kV and 345 kV) on common structures.													

### 3.2. Transformer Inventory Data

<b>Form 3.2</b>							
NERC ID: <a href="#">NCR00000</a>							
Transmission Owner (TO): <a href="#">ABC Power &amp; Light Co.</a>							
Regional Entity: <a href="#">TRE</a>		[1]					
Country: <a href="#">US</a>		[1]					
Reporting (Calendar) Year: <a href="#">2008</a>							
<b>Transformer Inventory Data</b>							
	(A)	(B)	(C)	(D)	(E)	(F)	(G)
Row No.	Voltage Class [2]	No. of Transformers (End-of-Year) [3]	No. of Transformers Added	Equivalent Annual No. of Transformers Added [4]	No. of Transformers Removed	Equivalent Annual No. of Transformers Removed [4]	<b>CALCULATED Annual Equivalent No. of Transformers = B-C+D+F</b>
1	200-299 kV	26.0	1.0	0.6	1.0	0.6	26.2
2	300-399 kV	NA	NA	NA	NA	NA	NA
3	400-599 kV	NA	NA	NA	NA	NA	NA
4	600-799 kV	NA	NA	NA	NA	NA	NA
<b>Notes:</b>							
[1] If a TO owns assets in a different NERC Region or in a different country, provide data for each Region and country in a separate workbook.							
[2] Report high-side phase-to-phase voltage. However, to be reported on this Form 3.2, the Transformer must have a low-side voltage that is ≥ 200 kV.							
[3] Only report transformers that are "in-service." Do not include spares.							
[4] See example in the Data Reporting Instruction Manual, Appendix 7.							

### 3.3. AC/DC Back-to-Back Converter Inventory Data

<b>Form 3.3</b>							
NERC ID		NCR00000					
Transmission Owner (TO):		ABC Power & Light Co.					
Regional Entity:		TRE		[1]			
Country:		US		[1]			
Reporting (Calendar) Year:		2008					
<b>AC/DC Back-to-Back Converter Inventory Data</b>							
	(A)	(B)	(C)	(D)	(E)	(F)	(G)
Row No.	Voltage Class [2]	No. of Converters (End-of-Year)	No. of Converters Added	Equivalent Annual No. of Converters Added [3]	No. of Converters Removed	Equivalent Annual No. of Converters Removed [3]	<b>CALCULATED Annual Equivalent No. of Converters = B-C+D+F</b>
1	200-299 kV	3.0	1.0	0.6	1.0	0.6	3.2
2	300-399 kV	NA	NA	NA	NA	NA	NA
3	400-499 kV	NA	NA	NA	NA	NA	NA
4	600-799 kV	NA	NA	NA	NA	NA	NA
<b>Notes:</b>							
[1] If a TO owns assets in a different NERC Region or in a different country, provide data for each Region and country in a separate workbook.							
[2] Report the highest terminal AC voltage (phase-to-phase).							
[3] See example in the Data Reporting Instruction Manual, Appendix 7							

### 3.4. Summary Automatic Outage Data

Form 3.4		CONFIDENTIAL INFORMATION			
NERC ID: NCR00000					
Transmission Owner (TO): ABC Power & Light Co.					
Regional Entity: TRE [1]					
Country: US [1]					
Reporting (Calendar) Year: 2008					
AC & DC Circuit Automatic Outage Data					
Row No.	(A) Voltage Class [2]	(B) No. of Sustained Outages	(C) No. of Momentary Outages	(D) No. of Circuits with Zero Automatic Outages [3]	(E) Calculated Percentage Circuits with Zero Automatic Outages expressed as %
1	200-299 kV AC Overhead	12	8	41	49.40%
2	300-399 kV AC Overhead	NA	NA	NA	NA
3	400-599 kV AC Overhead	NA	NA	NA	NA
4	600-799 kV AC Overhead	NA	NA	NA	NA
5	200-299 kV AC Underground	NA	NA	NA	NA
6	300-399 kV AC Underground	NA	NA	NA	NA
7	400-599 kV AC Underground	NA	NA	NA	NA
8	600-799 kV AC Underground	NA	NA	NA	NA
9	200-299 kV DC Overhead	NA	NA	NA	NA
10	300-399 kV DC Overhead	NA	NA	NA	NA
11	400-499 kV DC Overhead	NA	NA	NA	NA
12	500-599 kV DC Overhead	NA	NA	NA	NA
13	600-799 kV DC Overhead	NA	NA	NA	NA
14	200-299 kV DC Underground	NA	NA	NA	NA
15	300-399 kV DC Underground	NA	NA	NA	NA
16	400-499 kV DC Underground	NA	NA	NA	NA
17	500-599 kV DC Underground	NA	NA	NA	NA
18	600-799 kV DC Underground	NA	NA	NA	NA
Transformer Automatic Outage Data					
Row No.	(A) Voltage Class [4]	(B) No. of Sustained Outages	(C) No. of Momentary Outages	(D) Number of Transformers with Zero Automatic Outages [5]	(E) Calculated Percentage (%) Transformers with Zero Automatic Outages expressed as %
19	200-299 kV	3	8	21	80.77%
20	300-399 kV	NA	NA	NA	NA
21	400-599 kV	NA	NA	NA	NA
22	600-799 kV	NA	NA	NA	NA
AC/DC Back-to-Back Converters Automatic Outage Data					
Row No.	(A) Voltage Class [6]	(B) No. of Sustained Outages	(C) No. of Momentary Outages	(D) Number of Converters with Zero Automatic Outages [7]	(E) Calculated Percentage (%) Transformers with Zero Automatic Outages expressed as %
23	200-299 kV	0	4	2	66.67%
24	300-399 kV	NA	NA	NA	NA
25	400-599 kV	NA	NA	NA	NA
26	600-799 kV	NA	NA	NA	NA
<b>Notes:</b>					
[1] If a TO owns assets in a different NERC Region or in a different country, provide data for each Region and country in a separate workbook.					
[2] AC Circuit Voltages are phase-to-phase. DC Circuit Voltages are phase-to-return.					
[3] Only consider circuits with zero outages that are "in-service" at the end of the year.					
[4] Report high-side phase-to-phase voltage. However, to be reported, the Transformer must have a low-side voltage that is $\geq 200$ kV.					
[5] Only consider transformers with zero outages that are "in-service" at the end of the year. Do not include spares.					
[6] Report the highest terminal AC voltage (phase-to-phase).					
[7] Only consider converters with zero outages that are "in-service" at the end of the year.					

## Appendix 4 Forms for Detailed Automatic Outage Data

### 4.1. AC Circuit Detailed Automatic Outage Data

Form 4.1			CONFIDENTIAL INFORMATION												
NERC ID: NCR00000															
Transmission Owner (TO): ABC Power & Light Co.															
Regional Entity: TRE [1]															
Country: US [1]															
Reporting (Calendar) Year: 2008															
AC Circuit Momentary and Sustained Outage Data															
			Circuit Substation Boundaries									Cause Codes			
(A)	(B)	(C)	(D)	(E)	(F)	(G)	(H)	(I)	(J)	(K)	(L)	(M)	(N)	(O)	(P)
Outage ID Code	Event ID Code [2]	Voltage Class	Substation Name #1	Substation Name #2	Substation Name #3	TO Element Identifier (AC Circuit)	OH or UG?	AC Multi-Owner Com. Struct. Flag [3]	Fault Type	Outage Initiation Code	Start Time (dd/mm/yyyy hh:mm) (UTC)	Outage Duration hh:mm [5]	Initiating Cause Code [6]	Sustained Cause Code [7]	Outage Mode
100	A-2008	200-299 kV	Brown	Smith		BwSh#1	OH	0	No fault	AC Substation-Initiated	5/5/2008 13:04	1:20	Lightning	Failed Protection System Equipment	Dependent Mode Initiating
<b>Notes:</b>															
[1] If a TO owns assets in a different NERC Region or in a different country, provide data for each Region and country in a separate workbook.															
[2] The Event ID Code is defined on Form 5. If the outage is carried over from a previous year, use the Event ID Code for the original outage.															
[3] 0 = Not applicable (Circuit is not on common structures with another circuit, or the circuit is on common structures, but all circuits are owned by the reporting Transmission Owner. 1 = Circuit is on common structures, but circuits are owned by two different Transmission Owners															
[4] If the outage is carried over from a previous year, enter a "9999" as the Start Time. The Outage Duration will be input as if the outage commenced on on January 1, 00:00 UTC of the reporting year.															
[5] Report zero hours and zero minutes Outage Duration for Momentary Outages. For Sustained Outages that extend beyond the end of the reporting period, input a "9999" in the Outage Duration field; for outages that started in the previous reporting year and return to service in the reporting year, as if the outage commenced on January 1, 00:00 UTC.															
[6] For Momentary Outages, do not use the "Unavailable" Cause Code. For Sustained Outages, the "Unavailable" Cause Code may be used for either Initiating Outage Code or the Sustained Outage Code, but not both.															

## 4.2. DC Circuit Detailed Automatic Outage Data

Form 4.2			CONFIDENTIAL INFORMATION												
NERC ID: <a href="#">NCR00000</a>															
Transmission Owner (TO): <a href="#">ABC Power &amp; Light Co.</a>															
Regional Entity: <a href="#">TRE</a> [1]															
Country: <a href="#">US</a> [1]															
Reporting (Calendar) Year: <a href="#">2008</a>															
DC Circuit Momentary and Sustained Outage Data															
Circuit Terminal Boundaries												Cause Codes			
(A)	(B)	(C)	(D)	(E)	(F)	(G)	(H)	(I)	(J)	(K)	(L)	(M)	(N)	(O)	(P)
Outage ID Code	Event ID Code [2]	Voltage Class	AC/DC Terminal Name #1	AC/DC Terminal Name #2	AC/DC Terminal Name #3	TO Element Identifier (DC Circuit)	OH or UG?	NA	Fault Type	Outage Initiation Code	Start Time (dd/mm/yyyy hh:mm) (UTC)	Outage Duration hh:mm [4]	Initiating Cause Code [5]	Sustained Cause Code [6]	Outage Mode
101	B-2008	200-299 kV	Grey	Blue		GyBe#1	OH	NA	Phase target	Element-Initiated	5/5/2008 13:04	1:20	Vegetation	Failed Protection System Equipment	Single Mode
								NA							
								NA							
								NA							
								NA							
								NA							
								NA							
								NA							
								NA							
								NA							
								NA							
								NA							
								NA							
<b>Notes:</b>															
[1] If a TO owns assets in a different NERC Region or in a different country, provide data for each Region and country in a separate workbook.															
[2] The Event ID Code is defined on Form 5.															
[3] If the outage is carried over from a previous year, enter a "9999" as the Start Time. The Outage Duration will be input as if the outage commenced on on January 1, 00:00 UTC of the reporting year.															
[4] Report zero hours and zero minutes Outage Duration for Momentary Outages. For Sustained Outages that extend beyond the end of the reporting period, input a "9999" in the Outage Duration field; for outages that started in the previous reporting year and return to service in the reporting year, as if the outage commenced on January 1, 00:00 UTC.															
[5] For Momentary Outages, do not use the "Unavailable" Cause Code. For Sustained Outages, the "Unavailable" Cause Code may be used for either Initiating Outage Code or the Sustained Outage Code, but not both.															





## Appendix 5 Form for Event ID Code and Event Type Number Data

Form 5		CONFIDENTIAL INFORMATION	
NERC ID	NCR00000		
Transmission Owner (TO):	ABC Power & Light Co.		
Regional Entity:	TRE [1]		
Country	US [1]		
Reporting (Calendar) Year:	2008		
<b>Event Type No.</b>	<b>Table 1 Category from the TPL Standards</b>	<b>Description</b>	
10	B	Automatic Outage of an AC Circuit or Transformer with Normal Clearing.	
20	B	Automatic Outage of a DC Circuit with Normal Clearing.	
30	C	Automatic Outage of two ADJACENT AC Circuits on common structures with Normal Clearing.	
40	C	Automatic Outage of two ADJACENT DC Circuits on the common structures with Normal Clearing.	
50	NA	Other - please describe the event (optional)	
<b>Event ID Code Data</b>			
(A)	(B)	(C)	(D)
Event ID Code [2]	Event Type No. [3]	Description of Event Type No. 50 (Other) [4]	Disturbance Report Filed [5]
A-2008	10		Don't know
B-2008	20		Yes
C-2008	10		No
D-2008	10		No
<b>Notes:</b>			
[1] If a TO owns assets in a different NERC Region or in a different country, provide data for each Region and country in a separate workbook.			
[2] The Event ID Code must be appended by the reporting year no. (e.g., 2008). For the 1st quarter submissions in 2008, use "2008" and not "2008Q1" since this Event ID Code will be used for the entire reporting year.			
[3] See the Table above for Event Type No. Note that if Event Type No. 10 or 20 is selected, the Outage Mode on Forms 4.1, 4.2, or 4.3, (column P) must be "Single Mode Outage." Outages of an AC/DC Back-to-Back Converter (Form 4.4) must select Event Type No. 50.			
[4] <b>Optional input:</b> provide a brief description of the outage (for Event Type No. 50 only). Please limit the description to 500 characters or less.			
[5] Was an EOP-004 filed at NERC that was associated with the Event? Year-to-date public (i.e., non-confidential) data of all disturbance report filings are located at <a href="http://www.nerc.com/~filez/dawg-disturbancereports.html">http://www.nerc.com/~filez/dawg-disturbancereports.html</a> .			

## Appendix 6 TADS Definitions

The TADS Definitions is a separate document with its own page numbering.

**NERC**  
**Transmission Availability Data System (TADS)**  
**DEFINITIONS**

~~September 26~~ January X, 2007

## Table of Contents

A.	TADS Population Definitions.....	1
	1. Element .....	1
	2. Protection System .....	1
	3. AC Circuit .....	1
	4. Transformer .....	1
	5. AC Substation .....	1
	6. AC/DC Terminal.....	1
	7. AC/DC Back-to-Back Converter .....	1
	8. DC Circuit .....	2
	9. Overhead Circuit .....	2
	10. Underground Circuit .....	2
	11. Circuit Mile .....	2
	12. Multi-Circuit Structure Mile .....	2
	13. Voltage Class .....	2
B.	Outage Reporting Definitions.....	3
	1. Automatic Outage .....	3
	2. Momentary Outage: .....	3
	3. Sustained Outage: .....	3
	4. AC Multi-Owner Common Structure Flag.....	3
	5. In-Service State .....	3
	6. Substation, Terminal, or Converter Name .....	4
	7. TO Element Identifier .....	4
	8. Outage Start Time .....	4
	9. Outage Duration .....	4
	10. Outage Identification (ID) Code .....	5
	11. Event .....	5
	12. Event Identification (ID) Code.....	5
	13. Event Type Number .....	5
	14. Fault Type .....	6
	15. Normal Clearing.....	7
C.	Outage Initiation Codes .....	8
	1. Element-Initiated Outage .....	8
	2. Other Element-Initiated Outage .....	8
	3. AC Substation-Initiated Outage .....	8
	4. AC/DC Terminal-Initiated Outage.....	8
	5. Other Facility-Initiated Outage .....	8
D.	Outage Mode Codes .....	9
	1. Single Mode Outage.....	9
	2. Dependent Mode Initiating Outage .....	9
	3. Dependent Mode Outage.....	9
	4. Common Mode Outage.....	9
	5. Common Mode Initiating Outage .....	9
E.	Cause Codes Types.....	10
	1. Initiating Cause Code.....	10
	2. Sustained Cause Code .....	10
F.	Cause Codes.....	10
	1. Weather, excluding lightning.....	10
	2. Lightning.....	11
	3. Environmental.....	11

4.	Contamination .....	11
5.	Foreign Interference .....	11
6.	Fire .....	11
7.	Vandalism, Terrorism or Malicious Acts .....	11
8.	Failed AC Substation Equipment .....	11
9.	Failed AC/DC Terminal Equipment .....	11
10.	Failed Protection System Equipment .....	11
11.	Failed AC Circuit Equipment .....	11
12.	Failed DC Circuit Equipment .....	12
13.	Vegetation .....	12
14.	Power System Condition .....	12
15.	Human Error .....	12
16.	Unknown .....	12
17.	Other .....	12
18.	Unavailable .....	13

## **A. TADS Population Definitions**

### **1. Element**

The following are Elements for which TADS data are to be collected:

1. AC Circuits  $\geq 200$  kV (Overhead and Underground)
2. Transformers with  $\geq 200$  kV low-side voltage
3. AC/DC Back-to-Back Converters with  $\geq 200$  kV AC voltage, both sides
4. DC Circuits with  $\geq \pm 200$  kV DC voltage

### **2. Protection System**

Protective relays, associated communication systems, voltage and current sensing devices, station batteries and DC control circuitry.<sup>1</sup>

### **3. AC Circuit**

A set of AC overhead or underground three-phase conductors that are bound by AC Substations. Radial circuits are AC Circuits. See the Transformer exclusion in “In-Service State.”

The boundary of an AC Circuit extends to the transmission side of an AC Substation. The circuit breaker or disconnect switch are not considered part of the AC Circuit but instead are defined as part of the AC Substation. The AC Circuit includes the conductor, transmission structure, joints and dead-ends, insulators, ground wire, and other hardware, including in-line switches. [The AC Circuit includes in-line switches used to sectionalize portions of the AC Circuit even if they are within an AC Substation boundary.](#)

### **4. Transformer**

A bank comprised of three single-phase transformers or a single three-phase transformer. A Transformer is bounded by its associated switching or interrupting devices.

### **5. AC Substation**

An AC Substation includes the circuit breakers and disconnect switches which define the boundaries of an AC Circuit, as well as other facilities such as surge arrestors, buses, Transformers, wave traps, motorized devices, grounding switches, shunt or series capacitors, and reactors. Protection System equipment is excluded.

### **6. AC/DC Terminal**

A terminal that includes all AC and DC equipment needed for DC operation such as PLC (power-line carrier) filters, AC filters, reactors and capacitors, Transformers, DC valves, smoothing reactors and DC filters. On the AC side, an AC/DC Terminal is normally bound by AC breakers at the AC Substation bus where it is connected. On the DC side, it is bound by DC converters and filters. Protection System equipment is excluded.

### **7. AC/DC Back-to-Back Converter**

Two AC/DC Terminals in the same location with a DC bus between them. The boundaries are the AC breakers on each side.

---

<sup>1</sup> This definition is in the current NERC Glossary of Terms.

## 8. DC Circuit

One pole of an Overhead or Underground DC line which is bound by an AC/DC Terminal on each end.

## 9. Overhead Circuit

An AC or DC Circuit that is not an Underground Circuit. A cable conductor AC or DC Circuit inside a conduit which is *not* below the surface is an Overhead Circuit. A circuit that is part Overhead and part Underground is to be classified based upon the majority characteristic (Overhead Circuit or Underground Circuit) using Circuit Miles.

## 10. Underground Circuit

An AC or DC Circuit that is below the surface, either below ground or below water. A circuit that is part Overhead Circuit and part Underground Circuit is to be classified based upon the majority characteristic (Overhead Circuit or Underground Circuit) using Circuit Miles.

## 11. Circuit Mile

One mile of either a set of AC three-phase conductors in an Overhead or Underground AC Circuit, or one pole of a DC Circuit. A one mile-long, AC Circuit tower line that carries two three-phase circuits (i.e., a double-circuit tower line) would equate to two Circuit Miles. A one mile-long, DC tower line that carries two DC poles would equate to two Circuit Miles. Also, a one mile-long, common-trenched, double-AC circuit Underground duct bank that carries two three-phase circuits would equate to two Circuit Miles.

## 12. Multi-Circuit Structure Mile

A one-mile linear distance of sequential structures carrying multiple Overhead AC or DC Circuits. (Note: this definition is *not* the same as the industry term “structure mile.” A Transmission Owner’s Multi-Circuit Structure Miles will generally be less than its structure miles since not all structures contain multiple circuits.)

[If a line section contains two or more Multi-Circuit Structures which form one or more multi-circuit spans, the total span length can be measured and the associated mileage should be reported in the ‘Multi-Circuit Structure Mile’ total inventory. If multiple circuits are connected to only one common structure, that structure should be ignored for outage and inventory mileage purposes.](#)

## 13. Voltage Class

The following voltages classes will be used for reporting purposes:

1. 200 – 299 kV
2. 300 – 399 kV
3. 400 – 499 kV
4. 500 – 599 kV
5. 600 – 799 kV

For Transformers, the Voltage Class reported will be the high-side voltage, even though the cut-off voltage used in the definition is referenced on the low-side.

## **B. Outage Reporting Definitions**

### **1. Automatic Outage**

An outage which results from the automatic operation of a switching device, resulting in a normally in-service Element that is not in an In-Service State; i.e., there is a partial or full loss of continuous power flow through the Element to the system. A successful AC single-pole (phase) reclosing event is not an Automatic Outage.

### **2. Momentary Outage:**

An Automatic Outage with an Outage Duration less than one (1) minute. If the circuit recloses and trips again within less than a minute of the initial outage, it is only considered one outage. The circuit would need to remain in service for longer than one minute between the breaker operations to be considered as two outages.

### **3. Sustained Outage:<sup>2</sup>**

An Automatic Outage with an Outage Duration of a minute or greater.

### **4. AC Multi-Owner Common Structure Flag**

This flag identifies whether the outaged AC Circuit is on common structures with another circuit that is owned by a different Transmission Owner. This flag does not apply to DC Circuits which by default are all assumed to be on common structures with the circuits owned by the same Transmission Owner.

<u>Flag</u>	<u>Flag Interpretation</u>
-------------	----------------------------

- |   |  |
|---|--|
| 0 | Not applicable. The circuit is not on common structures with another circuit, or the circuit is on common structures, but all circuits are owned by the same Transmission Owner. No analysis of the Event ID Code or the Event Type Number is required by the Regional Entity.   |
| 1 | Circuit is on common structures with another circuit that is owned by a different Transmission Owner. The Regional Entity will need to examine Outage Start Times with this same flag to determine whether a second circuit had an outage with nearly the same Outage Start Time, and if so, whether the TOs properly coordinated their Event ID Codes and Event Type Numbers. |

### **5. In-Service State**

An Element that is energized and fully connected to the system. An exception is provided for a multi-terminal AC Circuit with a Transformer on one terminal. In this case, as illustrated below, the circuit is considered to be in an In-Service State even though Transformers and their associated switching or interrupting devices are not in service.

---

<sup>2</sup> The TADS definition of Sustained Outage is different than the NERC Glossary of Terms definition of Sustained Outage which is presently only used in FAC-003-1. The NERC Glossary of Terms defines a Sustained Outage as follows: "The deenergized condition of a transmission line resulting from a fault or disturbance following an unsuccessful automatic reclosing sequence and/or unsuccessful manual reclosing procedure." The definition is inadequate for TADS reporting for two reasons. First, it has no time limit that would distinguish a Sustained Outage from a Momentary Outage. Second, for a circuit with no automatic reclosing, the outage would not be "counted" if the TO has a successful manual reclosing under the NERC Glossary of Terms definition.

The illustrations below indicate the special handling of Transformers as they relate to a multi-terminal AC Circuit outage.

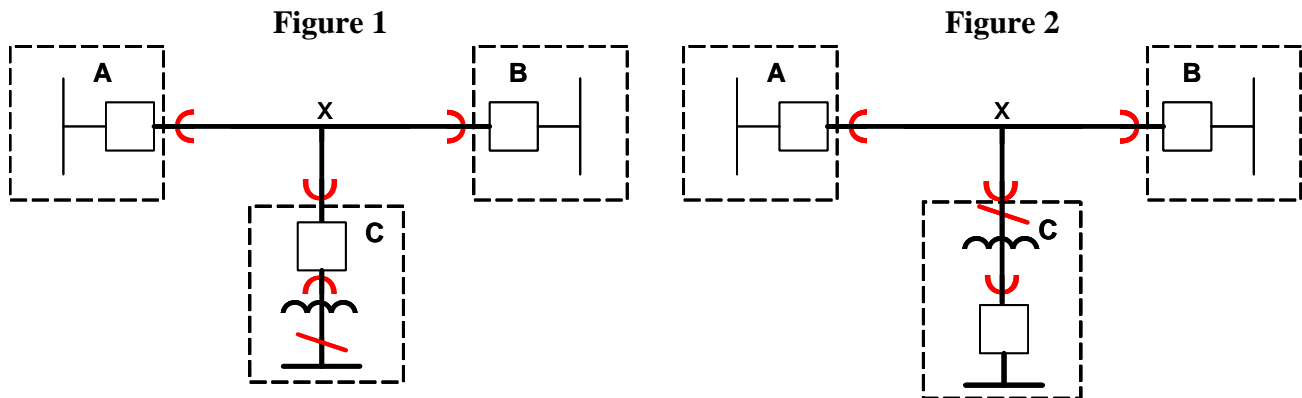

In both figures, the AC Circuit is bounded by AC Substations “A,” “B,” and “C” as indicated by the red arcs. The Transformer’s boundaries are the red disconnect switch and the red arc before the breaker. Note that the Transformer in either figure may *or* may not be a reportable Element (i.e., one with a low-side voltage  $\geq 200$  kV). For the multi-terminal exception, this difference does not matter.

Assume that each Transformer is out of service. Power cannot flow through the portion of the AC Circuit from “x” to Substation C because of the Transformer outage. Nevertheless, if all other portions of the AC Circuit are in service, the entire AC Circuit is considered to be in an In-Service State even if the Transformer is out of service. Because TADS does not recognize partial outage states, the multi-terminal exception above was developed so as to not overstate the outage contribution of a multi-terminal configuration of this type.

## 6. Substation, Terminal, or Converter Name

For Automatic Outages of AC Circuits and DC Circuits, the termination name at each end of the circuit will be reported to help identify *where* the circuit is located. For AC Circuits, these are the AC Substation Names; for DC Circuits, these are the AC/DC Terminal Names. For AC/DC Back-to-Back Converters, this is the Converter Station Name.

## 7. TO Element Identifier

An optional alphanumeric name that the TO may enter to identify the Element which is outaged (e.g., a circuit name.)

## 8. Outage Start Time

The date (mm/dd/yyyy) and time (hh:mm), rounded to the minute, that the Automatic Outage of an Element started. Outage Start Time is expressed in Coordinated Universal Time (UTC), not local time.

## 9. Outage Duration

The amount of time from the Outage Start Time to the when the Element is fully restored to original or to normal configuration, including equipment replacement. Outage

Duration is expressed as hours and minutes, rounded to the nearest minute. Momentary Outages are assigned a time of zero Outage Duration. TADS data is reported on a calendar-year basis, and the TADS Data Reporting Instruction Manual addresses the recording of the Outage Durations of a Sustained Outage that starts in one calendar year and concludes in another calendar year.

### 10. Outage Identification (ID) Code

A unique alphanumeric identifier assigned by the Transmission Owner to identify the reported outage of an Element.

### 11. Event

An Event is a transmission incident that results in the Sustained or Momentary outage of one or more Elements.

### 12. Event Identification (ID) Code

A unique alphanumeric identifier assigned by the Transmission Owner to an Event. Because outages that begin in one reporting year and end in the next reporting year must have the same Event ID Code, the code must have the reporting year appended to it to ensure its uniqueness. For example, an Event ID Code may be W324-2008. This unique Event ID Code establishes an easy way to identify which Automatic Outages are related to one another as defined by their Outage Mode Codes (see Section D).

1. An Event associated with a Single Mode Automatic Outage will have just one Event ID Code.
2. Each outage in a related set of two or more outages (e.g., Dependent Mode, Dependent Mode Initiating, Common Mode, or Common Mode Initiating) shall be given the same Event ID Code.

### 13. Event Type Number

A code that describes the type of Automatic Outage. The following Event Type Numbers will be used initially:

Event Type No.	Table 1 Category from the TPL Standards	Description
10	B	Automatic Outage of an AC Circuit or Transformer with Normal Clearing.
20	B	Automatic Outage of a DC Circuit with Normal Clearing.
30	C	Automatic Outage of two ADJACENT AC Circuits on common structures with Normal Clearing.
40	C	Automatic Outage of two ADJACENT DC Circuits on common structures with Normal Clearing.
50	NA	Other - please describe the event (optional)

To qualify for an Event Type No. 30 or 40, the outages must be a direct result of the circuits occupying common structures. These characteristics will generally apply.

1. The Outage Initiation Codes are either Element-Initiated or Other-Element Initiated.
2. The Outage Mode Codes are one of the following: (a) Dependent Mode Initiating (one outage) and Dependent Mode (second outage); (b) Common Mode Initiating and Common Mode (two outages); or (c) both Common Mode (two outages)

## Event Type No. 30 and 50 Examples

These are examples of Events that are Event Type No. 30:

1. A tornado outages two circuits on common structures. In this example, the outage is Element-Initiated and Common Mode. This is an Event Type No. 30 because the loss of both circuits was directly related to them being on the same structures.
2. On one circuit, a conductor breaks (outaging the circuit), and the conductor swings into a second circuit on common structures. The first circuit outage is Element-Initiated and Dependent Mode Initiating; the second circuit outage is Other-Element Initiated and Dependent Mode. This is an Event Type No. 30 because the second circuit's outage was a result of it being on common structures as the first circuit.

These Events are not an Event Type No. 30; instead, they are an Event Type No. 50.

1. Two AC Circuits on common structures are outaged due to a bus fault in the AC Substation where the circuits terminate. Both outages are Substation-Initiated and Common Mode. Because the outages are not a result of the two circuits being on common structures, it is not an Event Type No. 30. Therefore, it is an Event Type No. 50.
2. Two AC Circuits are on common structures and terminate at the same bus. Lightning strikes one AC Circuit, but the breaker fails to open due to a failure of a relay to operate properly. The second circuit, which is connected to the same bus, is outaged as a result of the first circuit's breaker ~~failed~~failure to open. The first outage is an Element-Initiated and Dependent Mode Initiating; the second outage is Other Facility-Initiated and Dependent Mode. (Note: the relay is excluded as part of an AC Substation, making the Outage Initiation Code "Other-Facility Initiated" and not "Substation-Initiated.") Because the outages are not a result of the two circuits being on common structures, it is not an Event Type No. 30. Therefore, it is an Event Type No. 50.

### **14. Fault Type**

The descriptor of the fault, if any, associated with ~~an each~~ Automatic Outage of an Element. Several choices are possible for each Element outage:

- ~~1. There was no target because no fault occurred~~
1. No fault (no targets on the outaged Element or no fault determined by best available data)
2. Phase target(s) (i.e., phase-to-phase fault(s) (P-P))
3. Ground target(s) (i.e., phase-to-ground ~~faults~~sfault (P-G))
4. ~~Both Multi~~-phase target(s) ~~and~~with or without ground target(s) (i.e. P-P-G or 3P fault)
5. Unknown target(s) (fault type unknown).

The Fault Type for each Element outage may be determined from recorded relay targets or by other analysis. TOs should use the best available data to determine (1) whether a fault occurred on each outaged Element and, if so, (2) what type of fault occurred. Relay targets should be documented as soon as practical after a fault and the targets re-set to prepare for the next fault. If a single fault results in several Element outages, the

protective relay targets associated with each Element indicate the Fault Type for that Outage. Relay targets are not a fool proof method to determine the Fault Type; however, they may be the best available data to determine Fault Type. An Element whose relays did not indicate a fault should be reported as “No Fault.”

Example: A 500 kV AC Circuit has a single line-to-ground fault that also results in an Outage of a 500/230 kV Transformer. The AC Circuit outage would have “Ground target” selected as the Fault Type, while the Transformer would have “No fault” selected.

### **15. Normal Clearing**

A protection system operates as designed and the fault is cleared in the time normally expected with proper functioning of the installed protection system.<sup>3</sup>

---

<sup>3</sup> This definition is in the current NERC Glossary of Terms.

## C. Outage Initiation Codes

The Outage Initiation Codes describe *where* an Automatic Outage was initiated on the power system.

### 1. Element-Initiated Outage

An Automatic Outage of an Element that is initiated on or within the Element that is outaged.

### 2. Other Element-Initiated Outage

An Automatic Outage of an Element that is initiated by another Element and not by the Element that is outaged.

### 3. AC Substation-Initiated Outage

An Automatic Outage of an Element that is initiated on or within AC Substation facilities

### 4. AC/DC Terminal-Initiated Outage

An Automatic Outage of an Element that is initiated on or within AC/DC Terminal facilities

### 5. Other Facility-Initiated Outage

An Automatic Outage that is initiated on or within other facilities. “Other facilities” include any facilities not includable in any other Outage Initiation Code. (Note: An Automatic Outage initiated on a Transformer that is *not* an Element is considered an AC Substation or an AC/DC Terminal-Initiated Outage since the Transformer would be considered part of an AC Substation or AC/DC Terminal.)

### Outage Initiation Code Examples

1. A Transformer which is an Element is outaged. Is its outage an Element-Initiated Outage or a Substation-Initiated Outage? It depends. If the outage initiated on or within the Element (e.g., an internal fault or a cracked insulator that caused a fault), the outage is Element-Initiated, even though the Transformer is in a Substation. However, if the Transformer outage was not due to the Transformer itself but due, for example, to a failed circuit breaker, it is Substation-Initiated.
2. An AC Circuit which is an Element has an outage that was initiated by a non-Element AC Circuit. The Element outage is Other Facility-Initiated.
3. An AC Circuit Outage was initiated by an Element Transformer outage. The AC Circuit Outage is Other Element-Initiated.

## D. Outage Mode Codes

The Outage Mode Code describes whether an Automatic Outage is related to other Automatic Outages.

### 1. Single Mode Outage

An Automatic Outage of a single Element which occurred independent of any other outages (if any).

### 2. Dependent Mode Initiating Outage

A Single Mode Outage that initiates one or more subsequent Automatic Outages.

### 3. Dependent Mode Outage

An Automatic Outage of an Element which occurred as a result of an initiating outage, whether the initiating outage was an Element outage or a non-Element outage. (Note: to re-emphasize, a Dependent Mode Outage must be a result of another outage.)

### 4. Common Mode Outage

One of two or more Automatic Outages with the same Initiating Cause Code and where the outages are not consequences of each other and occur nearly simultaneously (i.e., within cycles or seconds of one another).

### 5. Common Mode Initiating Outage

A Common Mode Outage that initiates one or more subsequent Automatic Outages.

#### Dependent Mode and Common Mode Outage Examples

1. A Dependent Mode Outage involves two outages, but one of the outages can be a non-Element outage. Therefore, not all Dependent Mode Outages will have an associated Dependent Mode Initiating Outage. If the initiating outage is one of the four defined Elements, that outage will be a Dependent Mode Initiating Outage, and the resulting second Element outage will be a Dependent Mode Outage. For example, suppose a 500 kV AC Circuit is outaged as a result of a 500/230 kV Transformer outage. The AC Circuit outage is a Dependent Mode Outage, and the Transformer outage is a Dependent Mode Initiating Outage. However, if an outage is not initiated by an Element, it will not have an associated Dependent Mode Initiating Outage. If the Transformer in the previous example had been a 345/138 kV Transformer and the AC Circuit a 345 kV circuit, the Transformer would not be an Element and, therefore, the AC Circuit outage would not have an associated Dependent Mode Initiating Outage. The AC Circuit outage would be classified as a Dependent Mode Outage since it was the result of a non-Element outage.
2. A Common Mode Outage involves the two outages, but unlike a Dependent Mode Outage, both outages must be Elements. In addition, one outage must not cause the second outage to occur; i.e., the two outages are not consequences of each other. In addition, they must occur nearly simultaneously. As an example, suppose that lightning strikes two AC Circuits in the same right of way (but not on a common structure) and both circuits are outaged nearly simultaneously.

Assume no further outages occur. Both are Common Mode Outages. Now assume the same scenario with a slight difference: one AC Circuit clears normally, the second AC Circuit does not, and there is a circuit breaker failure, resulting in the outage of a third AC Circuit. The first AC Circuit outage is a Common Mode Outage. The second AC Circuit outage is a Common Mode Initiating Outage, with the third AC Circuit outage a Dependent Mode Outage.

## **E. Cause Codes Types**

### **1. Initiating Cause Code**

The Cause Code that describes the initiating cause of the outage.

### **2. Sustained Cause Code**

The Cause Code that describes the cause that contributed to the longest duration of the outage. Momentary Outages do not have a Sustained Cause Code.

#### Initiating and Sustained Cause Code Examples

Suppose a lightning strike on an AC Circuit that should have cleared normally becomes a Sustained Outage because of breaker failure. “Lightning” is the Initiating Cause Code and “Failed AC Substation Equipment” is the Sustained Cause Code.

To illustrate the meaning of the phrase “contributed to the longest duration” in the definition above, suppose that lightning caused a conductor to break (“Failed AC Circuit Equipment”) and that the breaker for the circuit also failed (“Failed AC Substation Equipment”). This example has two possible Sustained Outage Cause Codes, and the one to select is the one that contributed to the longest duration. If the conductor was repaired before the circuit breaker, then “Failed AC Substation Equipment” is the Sustained Cause Code since the circuit breaker outage contributed to the longest duration.

Special Exception for 2008 Reporting: For reporting in 2008, Transmission Owners should supply both the Initiating and Sustained Cause Codes if they have them available. However, if both Cause Codes are not available, at least one Cause Code, either Initiating or Sustained, must be supplied for a Sustained Outage. (Momentary Outages still must have their Initiating Cause Code reported.) As an example, suppose a TO only has the Initiating Outage Cause Code available to it for Sustained Outages. The Initiating Cause Code would be entered for each outage, and the appropriate Sustained Cause Code would be “Unavailable.” On the other hand, suppose only a Sustained Cause Code is available. Sustained Outages would then have their Initiating Outage Codes reported as “Unavailable.” The “Unavailable” code will be deleted in 2009 when TOs are expected to have both Initiating and Sustained Cause Codes available.

## **F. Cause Codes**

### **1. Weather, excluding lightning**

Automatic Outages caused by weather such as snow, extreme temperature, rain, hail, fog, sleet/ice, wind (including galloping conductor), tornado, microburst, dust storm, and flying debris caused by wind.

## **2. Lightning**

Automatic Outages caused by lightning.

## **3. Environmental**

Automatic Outages caused by environmental conditions such as earth movement (including earthquake, subsidence, earth slide), flood, geomagnetic storm, or avalanche.

## **4. Contamination**

Automatic Outages caused by contamination such as bird droppings, dust, corrosion, salt spray, industrial pollution, smog, or ash.

## **5. Foreign Interference**

Automatic Outages caused by foreign interference from such objects such as an aircraft, machinery, a vehicle, a train, a boat, a balloon, a kite, a bird (including streamers), an animal, flying debris not caused by wind, and falling conductors from one line into another. Foreign Interference is not due to an error by a utility employee or contractor. Categorize these as “Human Error.”

## **6. Fire**

Automatic Outages caused by fire or smoke.

## **7. Vandalism, Terrorism or Malicious Acts**

Automatic Outages caused by intentional activity such as shot conductors or insulators, removing bolts from structures, and bombs.

## **8. Failed AC Substation Equipment**

Automatic Outages caused by the failure of AC Substation; i.e., equipment “inside the substation fence” including Transformers and circuit breakers but excluding Protection System equipment. Refer to the definition of “AC Substation.”

## **9. Failed AC/DC Terminal Equipment**

Automatic Outages caused by the failure of AC/DC Terminal equipment; i.e., equipment “inside the terminal fence” including PLC (power-line carrier) filters, AC filters, reactors and capacitors, Transformers, DC valves, smoothing reactors, and DC filters but excluding Protection System equipment. Refer to the definition of “AC/DC Terminal.”

## **10. Failed Protection System Equipment**

Automatic Outages caused by the failure of Protection System equipment. Includes any relay and/or control misoperations *except* those that are caused by incorrect relay or control settings that do not coordinate with other protective devices. Categorize these as “Human Error”.

## **11. Failed AC Circuit Equipment**

Automatic Outages related to the failure of AC Circuit equipment, i.e., overhead or underground equipment “outside the substation fence.” Refer to the definition of “AC Circuit.”

## **12. Failed DC Circuit Equipment**

Automatic Outages related to the failure DC Circuit equipment, i.e., overhead or underground equipment “outside the terminal fence.” Refer to the definition of “DC Circuit.” However, include the failure of a connecting DC bus within an AC/DC Back-to-Back Converter in this category.

## **13. Vegetation**

Automatic Outages (both Momentary and Sustained) caused by vegetation, with the exception of the following exclusions which are contained in FAC-003-1:

1. Vegetation-related outages that result from vegetation falling into lines from outside the right of way that result from natural disasters shall not be considered reportable with the Vegetation Cause Code. Examples of disasters that could create non-reportable Vegetation Cause Code outages include, but are not limited to, earthquakes, fires, tornados, hurricanes, landslides, wind shear, major storms as defined either by the Transmission Owner or an applicable regulatory body, ice storms, and floods, and
2. Vegetation-related outages due to human or animal activity shall not be considered reportable under the Vegetation Cause Code. Examples of human or animal activity that could cause a non-reportable Vegetation Cause Code outage include, but are not limited to, logging, animal severing tree, vehicle contact with tree, arboricultural activities or horticultural or agricultural activities, or removal or digging of vegetation.

Outages that fall under the exclusions should be reported under another Cause Code and not the Vegetation Cause Code.

## **14. Power System Condition**

Automatic Outages caused by power system conditions such as instability, overload trip, out-of-step, abnormal voltage, abnormal frequency, or unique system configurations (e.g., an abnormal terminal configuration due to existing condition with one breaker already out of service).

## **15. Human Error**

Automatic Outages caused by any incorrect action traceable to employees and/or contractors for companies operating, maintaining, and/or providing assistance to the Transmission Owner will be identified and reported in this category. Also, any human failure or interpretation of standard industry practices and guidelines that cause an outage will be reported in this category.

## **16. Unknown**

Automatic Outages caused by unknown causes should be reported in this category.

## **17. Other**

Automatic Outages for which the cause is known; however, the cause is not included in the above list.

## **18. Unavailable**

Use for Sustained Outages for which either the Initiating or Sustained Cause Codes are unavailable to the Transmission Owner. If a Transmission Owner uses this code, it should be used on only *one* type of Cause Code (Initiating or Sustained), whichever is unavailable. If during 2008, both Cause Codes become available to the Transmission Owner, stop using “Unavailable.” The “Unavailable” code will be withdrawn in 2009.

## Appendix 7 Inventory Data Examples

The following examples demonstrate a calculation method that can be used to complete the TADS inventory spreadsheet data on Form 3.1 associated with the number of AC Circuits, the number of Circuit Miles, and the number of Multi-Circuit Structure Miles. However, the methods used to determine the inventory data associated with the number of AC Circuits can be used for any Element.

The TADS Task Force acknowledges that other calculation methods can be utilized to complete the inventory spreadsheet. Every reporting entity must determine the method that is best for their organization.



**Calculation 1: No. of AC Circuits and Circuit Miles that were *in-service* at the end of the reporting year [FORM 3.1]**

Circuit Miles calculations (Elements at the end of the year)	
Element Identification	Circuit Miles
AB-1	25
AB-2	25
BD-1	25
BD-2	25
AE	25
AC	25
CD-1	25
DF	75
CD-2	25
CF	50
<b>Total Circuit Miles</b>	<b>325</b>

10 would be entered into the column titled “No. of Circuits (End of Year)”  
 325 would be entered into the column titled “Circuit miles (End of Year)”

**Calculation 2: No. of AC Circuits and Circuit Miles that were *added or removed* during the reporting year [FORM 3.1]**

Circuit Miles Calculations (Elements added, retired or changed during the year)				
Element Identification	Circuit Miles	Number of Days from In-Service date to the end of the reporting year	Equivalent Annual Element Value	Equivalent Circuit Miles
CD-2	25	205	.56	14.04
CF	50	61	.17	8.36
Totals for Elements added			.73	22.4
Element Identification	Circuit Miles	Number of days from retirement/change date to the beginning of the reporting year	Equivalent Annual Element Value	Equivalent Circuit Miles
CE	30	91	.25	7.4
Total for Elements retired or changed			.25	7.4

2 would be entered into the column titled “No. of Circuits Added”  
 0.73 would be entered into the column titled “Equivalent Annual No. of Circuits Added [3]”  
 $(205/366) + (61/366) = 0.73$       **(2008 is a leap year)**

75 would be entered into the column titled “No. of Circuit Miles for Circuits Added”  
 22.4 would be entered into the column titled “Equivalent Annual No. of Circuit Miles for Circuits Added [3]”

$$25 \text{ Miles } (205/366) + 50 \text{ Miles } (61/366) = 22.4 \quad \text{(2008 is a leap year)}$$

1 would be entered into the column titled “No. of Circuits removed”

.25 would be entered into the column titled “Equivalent Annual No. of Circuits Removed [3]”  $91/366 = .25$  **(2008 is a leap year)**

30 would be entered into the column titled “No. of Circuit Miles for Circuits Removed”

7.4 would be entered into the column titled “Equivalent Annual No. of Circuit Miles for Circuits Removed [3]”

$$30 \text{ Miles } (91/366) = 7.4 \quad \text{(2008 is a leap year)}$$

**Calculation 3: Multi-Circuit Structure Miles for AC Circuits that were in-service at the end of the reporting year [FORM 3.1]**

Multi-Circuit Structure Miles Calculations (Elements at the end of the year)	
Element Identification	Multi-Circuit Structure Miles
AB-1 & AB-2	25
AC & AE	10
CD-1 & CD-2	25
Total Structure Miles	60

60 would be entered into the column titled “Multi-Circuit Structure Miles (End of Year)”

**Calculation 4: Multi-Circuit Structure Miles for AC Circuits that were added or removed during the reporting year [FORM 3.1]**

Multi-Circuit Structure Miles Calculations (Elements added during the year)			
Element Identification	Multi-Circuit Structure Miles	Number of Days from In-Service date to the end of the reporting year	Equivalent Multi-Circuit Structure Miles
CD-1 & CD-2	25	205	14.04
Total Equivalent Structure Miles added during the year			14.04

25 would be entered into the column titled “Multi-Circuit Structure Miles for Circuits Added”

14.04 would be entered into the column titled “Equivalent Annual No. of Multi-Circuit Structure Miles for Circuits Added”

$$25 \text{ Structure Miles } (205/366) = 14.04 \quad \text{(2008 is a leap year)}$$

### Two Questions in Form 3.1

Base Example:

None of Multi-Circuit Structure Miles are on a common structure owned by another Transmission Owner.

								Answers
24	Transmission Owner Coordination Questions	1. Do any of the Multi-Circuit Structure Miles contain circuits on the common structures that are owned by you and another Transmission Owner(s)?						No
25		2. If the answer to question 1 is "yes," have you and the other Transmission Owner(s) coordinated your reporting to insure that no double counting of Multi-Circuit Structure Miles are being reported for the circuits on these structures?						Not applicable

**Situation 1:**

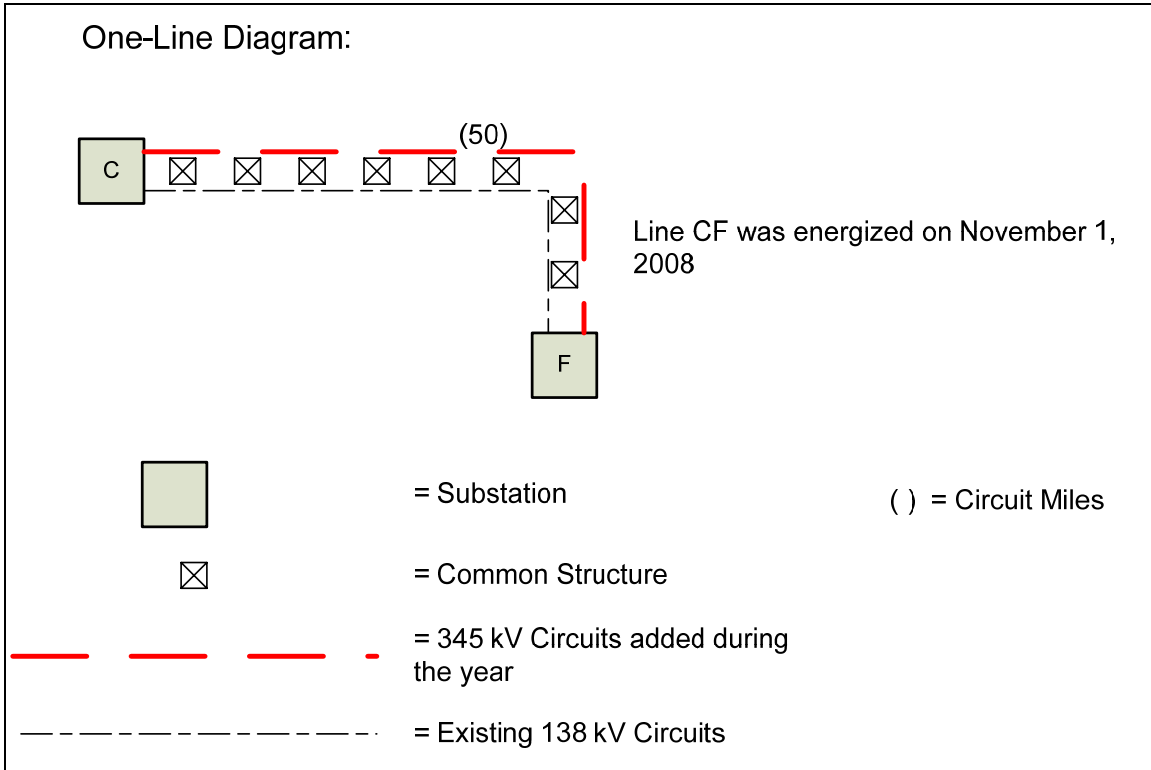

**Figure 2: The addition of a TADS Element on a common structure with a non-TADS Element**

In this situation AC Circuit CF was placed on a common structure with an existing 138 kV circuit. For TADS this common structure situation shall not be included in the Multi-Circuit Structure Mile calculation. For TADS you are only to report those Multi-Circuit Structure Miles where two or more TADS Elements share a common structure.

The calculations for AC Circuit CF are the same as in the Base Model.

### Base Case and Situation 1 Inventory Data, Form 3.1

AC and DC Circuit Inventory Data													
	(A)	(B)	(C)	(D)	(E)	(F)	(G)	(H)	(I)	(J)	(K)	(L)	(M)
Row No.	Voltage Class [2]	No. of Circuits (End-of-Year)	Circuit Miles (End-of-Year)	No. of Circuits Added	Equivalent Annual No. of Circuits Added [3]	No. of Circuit Miles for Circuits Added	Equivalent Annual No. of Circuit Miles for Circuits Added [3]	No. of Circuits Removed	Equivalent Annual No. of Circuits Removed [3]	No. of Circuit Miles for Circuits Removed	Equivalent Annual No. of Circuit Miles for Circuits Removed [3]	CALCULATED Annual Equivalent No. of Circuits = B-D+E+I	CALCULATED Annual Equivalent No. of Circuit Miles = C-F+G+K
1	200-299 kV AC Overhead	NA	NA	NA	NA	NA	NA	NA	NA	NA	NA	NA	NA
2	300-399 kV AC Overhead	10	335.0	2	0.73	75.0	22.4	1	0.25	30.0	7.4	9.0	289.8
3	400-599 kV AC Overhead	NA	NA	NA	NA	NA	NA	NA	NA	NA	NA	NA	NA
4	600-799 kV AC Overhead	NA	NA	NA	NA	NA	NA	NA	NA	NA	NA	NA	NA

AC Multi-Circuit Structure Miles Inventory Data													
	(A)	(B)	(C)	(D)	(E)	(F)	(G)	(H)	(I)	(J)	(K)	(L)	(M)
	Voltage Class [2]	NA	Multi-Circuit Structure Miles (End-of-Year)	NA	NA	No. of Multi-Circuit Structure Miles for Circuits Added	Equivalent Annual No. of Multi-Circuit Structure Miles for Circuits Added [3]	NA	NA	No. of Multi-Circuit Structure Miles for Circuits Removed	Equivalent Annual No. of Multi-Circuit Structure Miles for Circuits Removed [4]	NA	CALCULATED Annual Equivalent No. of Multi-Circuit Structure Miles = C-F+G+K
19	200-299 kV AC	NA	NA	NA	NA	NA	NA	NA	NA	NA	NA	NA	NA
20	300-399 kV AC	NA	60.0	NA	NA	25.0	14.0	NA	NA	0.0	0.0	NA	49.0
21	400-599 kV AC	NA	NA	NA	NA	NA	NA	NA	NA	NA	NA	NA	NA
22	600-799 kV AC	NA	NA	NA	NA	NA	NA	NA	NA	NA	NA	NA	NA
23	Mixed Voltages [4]	NA	NA	NA	NA	NA	NA	NA	NA	NA	NA	NA	NA

**Situation 2:**

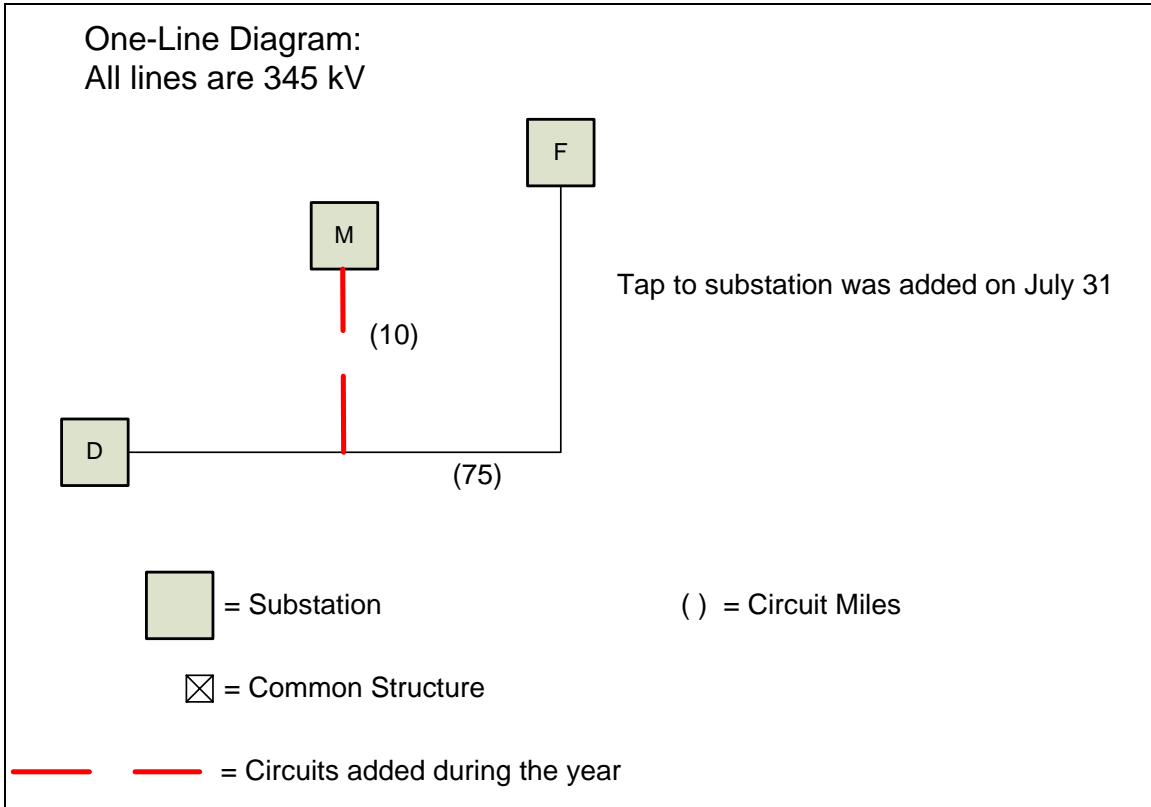

**Figure 3: Tap addition**

In this example we are demonstrating how to calculate your inventory data if, in addition to the work that was done in the Base Model, you added a 10 mile tap off AC Circuit DF.

**Calculation 1a: No. of AC Circuits and Circuit Miles that were in-service at the end of the reporting year [FORM 3.1]**

Circuit Miles calculations (Elements at the end of the year)	
Element Identification	Circuit Miles
AB-1	25
AB-2	25
BD-1	25
BD-2	25
AE	25
AC	25
CD-1	25
DMF	85
CD-2	25
CF	50
Total Circuit Miles	335

10 would be entered into the column titled “No. of Circuits (End of Year)”  
 335 would be entered into the column titled “Circuit miles (End of Year)”

**Calculation 2a: No. of AC Circuits and Circuit Miles that were added or removed during the reporting year [FORM 3.1]**

Circuit Miles Calculations (Elements added, retired or changed during the year)				
Element Identification	Circuit Miles	Number of days from in-service date through the end of the reporting year	Equivalent Annual Element Value	Equivalent Circuit Miles
CD-2	25	205	.56	14.04
CF	50	61	.17	8.36
DFM	85	154	.42	35.7
Totals for Elements added			1.15	58.1
Element Identification	Circuit Miles	Number of days from retirement/change date to the beginning of the reporting year	Equivalent Annual Element Value	Equivalent Circuit Miles
CE	30	91	.25	7.4
DF	75	212	.58	43.5
Total for Elements retired or changed			.83	50.9

3 would be entered into the column titled “No. of Circuits Added”

1.15 would be entered into the column titled “Equivalent Annual No. of Circuits Added [3]” (*Excel will display to the first significant digit*)

$$(205/366) + (61/366) + (154/366) = 1.15 \quad \text{(2008 is a leap year)}$$

160 would be entered into the column titled “No. of Circuit Miles for Circuits Added”

58.1 would be entered into the column titled “Equivalent Annual No. of Circuit Miles for Circuits Added [3]”

$$25 \text{ Miles } (205/366) + 50 \text{ Miles } (61/366) + 85 \text{ Miles } (154/366) = 58.1$$

**(2008 is a leap year)**

2 would be entered into the column titled “No. of Circuits removed”

.83 would be entered into the column titled “Equivalent Annual No. of Circuits Removed [3]”  $(91/366) + (212/366) = .83$  **(2008 is a leap year)**

105 would be entered into the column titled “No. of Circuit Miles for Circuits Removed”

50.9 would be entered into the column titled “Equivalent Annual No. of Circuit Miles for Circuits Removed [3]”

$$30 \text{ Miles } (91/366) + 75 \text{ Miles } (212/366) = 50.9 \quad \text{(2008 is a leap year)}$$

**Calculation 3a: Multi-Circuit Structure Miles for AC Circuits that were in-service at the end of the reporting year [FORM 3.1]**

This calculation is the same as in the Base Model.

**Calculation 4a: Multi-Circuit Structure Miles for AC Circuits that were added or removed during the reporting year. [FORM 3.1]**

This calculation is the same as in the Base Model.

### Situation 2 Inventory Data, Form 3.1

AC and DC Circuit Inventory Data													
	(A)	(B)	(C)	(D)	(E)	(F)	(G)	(H)	(I)	(J)	(K)	(L)	(M)
Row No.	Voltage Class [2]	No. of Circuits (End-of-Year)	Circuit Miles (End-of-Year)	No. of Circuits Added	Equivalent Annual No. of Circuits Added [3]	No. of Circuit Miles for Circuits Added	Equivalent Annual No. of Circuit Miles for Circuits Added [3]	No. of Circuits Removed	Equivalent Annual No. of Circuits Removed [3]	No. of Circuit Miles for Circuits Removed	Equivalent Annual No. of Circuit Miles for Circuits Removed [3]	CALCULATED Annual Equivalent No. of Circuits = B-D+E+I	CALCULATED Annual Equivalent No. of Circuit Miles = C-F+G+K
1	200-299 kV AC Overhead	NA	NA	NA	NA	NA	NA	NA	NA	NA	NA	NA	NA
2	300-399 kV AC Overhead	10	335.0	3	1.20	160.0	58.1	2	0.83	105.0	50.9	9.0	284.0
3	400-599 kV AC Overhead	NA	NA	NA	NA	NA	NA	NA	NA	NA	NA	NA	NA
4	600-799 kV AC Overhead	NA	NA	NA	NA	NA	NA	NA	NA	NA	NA	NA	NA

**Multi-Circuit Structure Miles data is the same as the Base Case**

**Situation 3:**

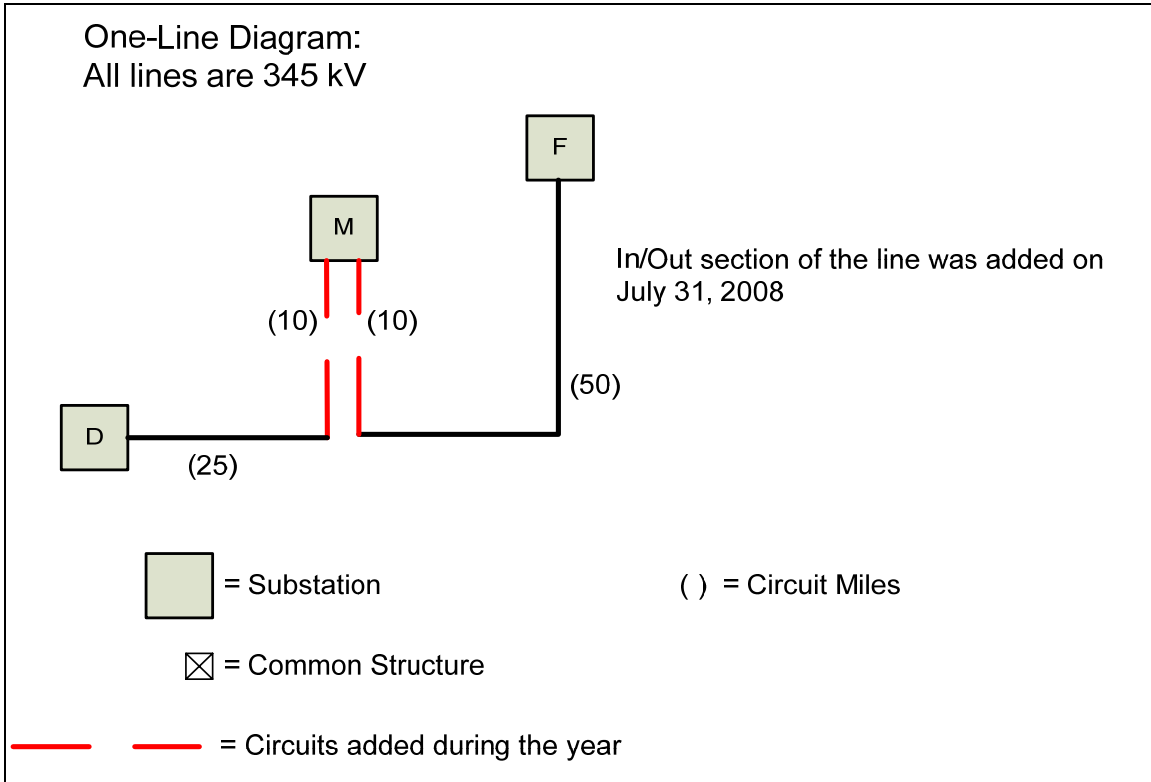

**Figure 4: In/Out section addition**

In this example we are demonstrating how to calculate your inventory data if, in addition to the work that was done in the Base Model, you added two 10-mile sections for a new substation.

**Calculation 1b: No. of AC Circuits and Circuit Miles that were in-service at the end of the reporting year [FORM 3.1]**

Circuit Miles calculations (Elements at the end of the year)	
Element Identification	Circuit Miles
AB-1	25
AB-2	25
BD-1	25
BD-2	25
AE	25
AC	25
CD-1	25
DM	35
MF	60
CD-2	25
CF	50
<b>Total Circuit Miles</b>	<b>345</b>

11 would be entered into the column titled “No. of Circuits (End of Year)”  
 345 would be entered into the column titled “Circuit miles (End of Year)”

**Calculation 2b: No. of AC Circuits and Circuit Miles that were added or removed during the reporting year [FORM 3.1]**

Circuit Miles Calculations (Elements added, retired or changed during the year)				
Element Identification	Circuit Miles	Number of days from in-service date through the end of the reporting year	Equivalent Annual Element Value	Equivalent Circuit Miles
CD-2	25	205	.56	14.04
CF	50	61	.17	8.36
DM	35	154	.42	14.7
MF	60	154	.42	25.2
Totals for Elements added			1.57	62.3
Element Identification	Circuit Miles	Number of days from retirement/change date to the beginning of the reporting year	Equivalent Annual Element Value	Equivalent Circuit Miles
CE	30	91	.25	7.4
DF	75	212	.58	43.5
Total for Elements retired or changed			.83	50.9

4 would be entered into the column titled “No. of Circuits Added”  
 1.57 would be entered into the column titled “Equivalent Annual No. of Circuits Added [3]”  $(205/366) + (61/366) + (154/366) + (154/366) = 1.57$  **(2008 is a leap year)**  
 170 would be entered into the column titled “No. of Circuit Miles for Circuits Added”  
 62.3 would be entered into the column titled “Equivalent Annual No. of Circuit Miles for Circuits Added [3]”

$25 \text{ Miles } (205/366) + 50 \text{ Miles } (61/366) + 35 \text{ Miles } (154/366) + 60 \text{ Miles } (154/366) = 62.3$   
**(2008 is a leap year)**

2 would be entered into the column titled “No. of Circuits removed”  
 .83 would be entered into the column titled “Equivalent Annual No. of Circuits Removed [3]”  $(91/366) + (212/366) = .83$  **(2008 is a leap year)**  
 105 would be entered into the column titled “No. of Circuit Miles for Circuits Removed”  
 50.9 would be entered into the column titled “Equivalent Annual No. of Circuit Miles for Circuits Removed [3]”

$30 \text{ Miles } (91/366) + 75 \text{ Miles } (212/366) = 50.9$  **(2008 is a leap year)**

**Calculation 3b: Multi-Circuit Structure Miles for AC Circuits that were in-service at the end of the reporting year [FORM 3.1]**

This calculation is the same as in the Base Model.

**Calculation 4b: Multi-Circuit Structure Miles for AC Circuits that were added or removed during the reporting year [FORM 3.1]**

This calculation is the same as in the Base Model.

### Situation 3 Inventory Data, Form 3.1

AC and DC Circuit Inventory Data													
	(A)	(B)	(C)	(D)	(E)	(F)	(G)	(H)	(I)	(J)	(K)	(L)	(M)
Row No.	Voltage Class [2]	No. of Circuits (End-of-Year)	Circuit Miles (End-of-Year)	No. of Circuits Added	Equivalent Annual No. of Circuits Added [3]	No. of Circuit Miles for Circuits Added	Equivalent Annual No. of Circuit Miles for Circuits Added [3]	No. of Circuits Removed	Equivalent Annual No. of Circuits Removed [3]	No. of Circuit Miles for Circuits Removed	Equivalent Annual No. of Circuit Miles for Circuits Removed [3]	CALCULATED Annual Equivalent No. of Circuits = B-D+E+I	CALCULATED Annual Equivalent No. of Circuit Miles = C-F+G+K
1	200-299 kV AC Overhead	NA	NA	NA	NA	NA	NA	NA	NA	NA	NA	NA	NA
2	300-399 kV AC Overhead	11	345.0	4	1.57	170.0	62.3	2	0.83	105.0	50.9	9.4	288.2
3	400-599 kV AC Overhead	NA	NA	NA	NA	NA	NA	NA	NA	NA	NA	NA	NA
4	600-799 kV AC Overhead	NA	NA	NA	NA	NA	NA	NA	NA	NA	NA	NA	NA

**Multi-Circuit Structure Miles data is the same as the Base Case**

## **Appendix 8 Detailed Outage Data Examples**

The following examples illustrate several AC Circuit and Transformer outage scenarios and the applicable detailed outage data for each scenario. While not all possible situations could be covered, the examples are complete enough to help with outage interpretation.

## Three-terminal AC Circuit with a non-TADS Element

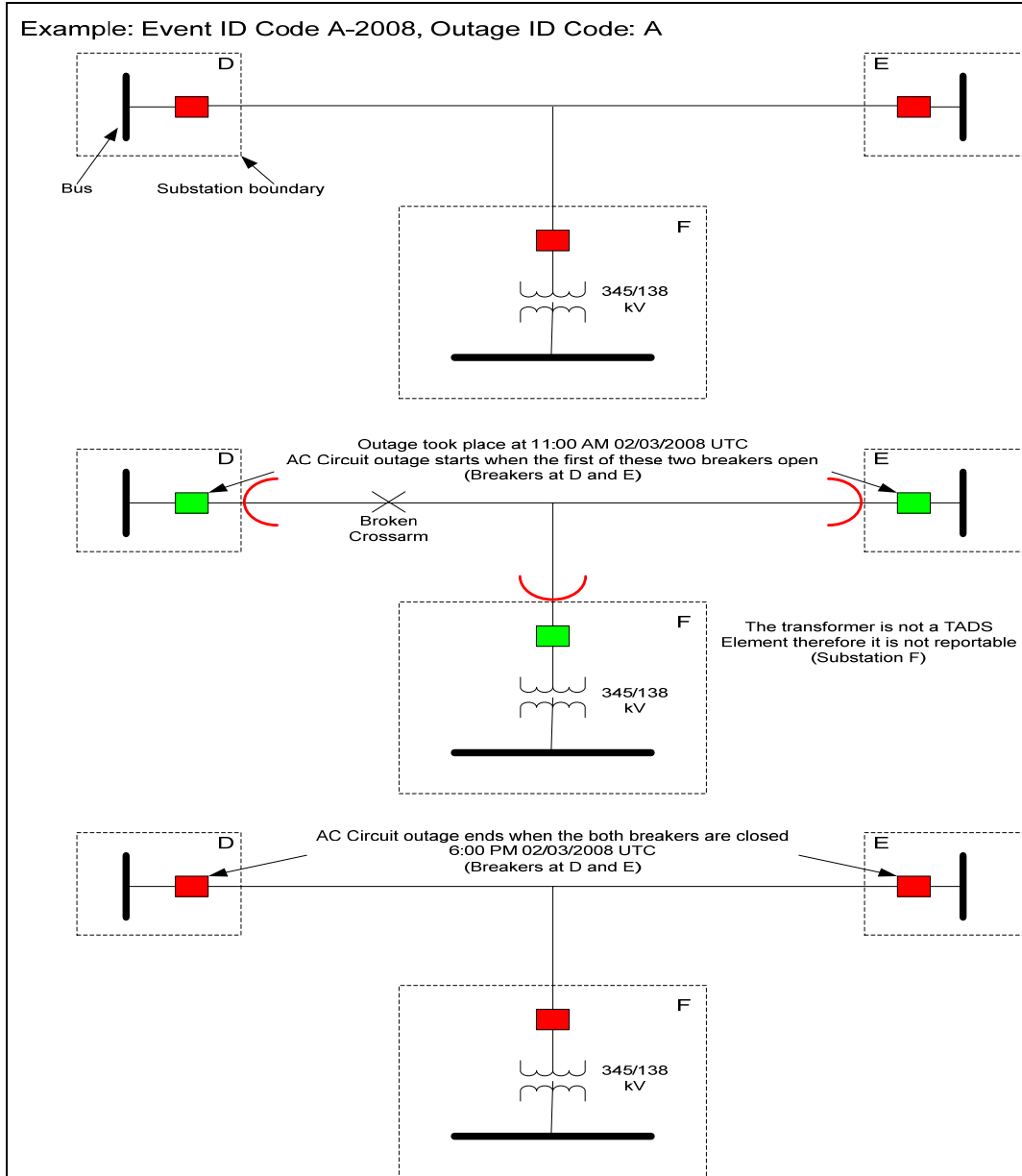

A three terminal AC Circuit with a non-TADS Element attached to one of the segments. The non-TADS element is the 345/138 kV transformer.

Since the transformer is not a TADS Element outages to the transformer are not reportable.

Outage Mode: Single Mode Outage

This is a Single Mode Outage because the 345/138 kV transformer is not a TADS Element.

## Three-terminal AC Circuit with a TADS Element

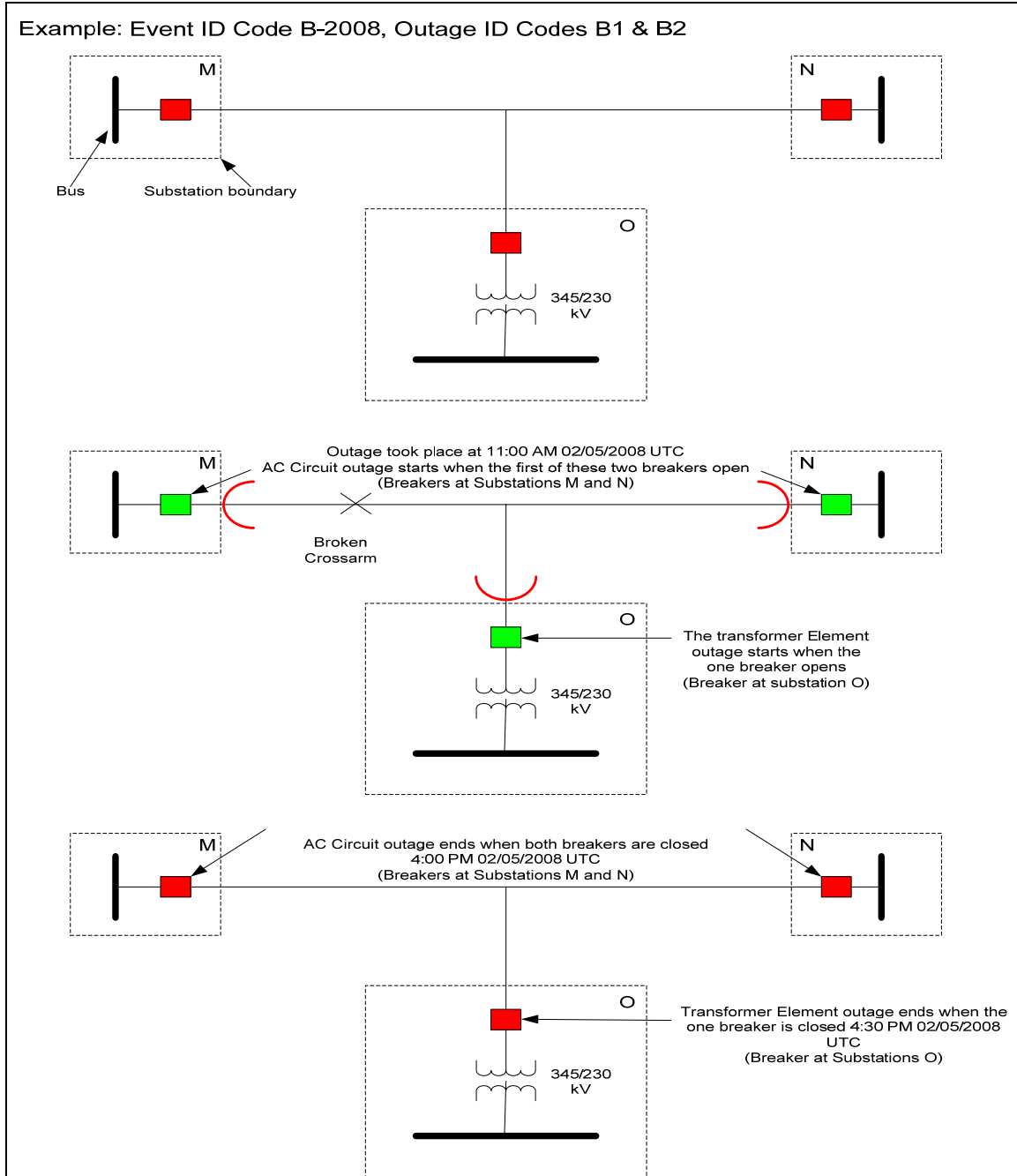

A three terminal AC Circuit with a TADS Transformer attached to one of the segments.

Since the transformer is a TADS Element outages to the transformer are reportable.

Outage Mode: Dependent Mode Initiating Outage (For the AC Circuit)

Outage Mode: Dependent Mode Outage (For the Transformer)

This is a Dependent Mode because the outage of the transformer is dependent on the outage of the AC Circuit.

## Bus fault that interrupts TADS Elements

Example: Event ID Code C-2008, Outage ID Codes, C1, C2 and C3

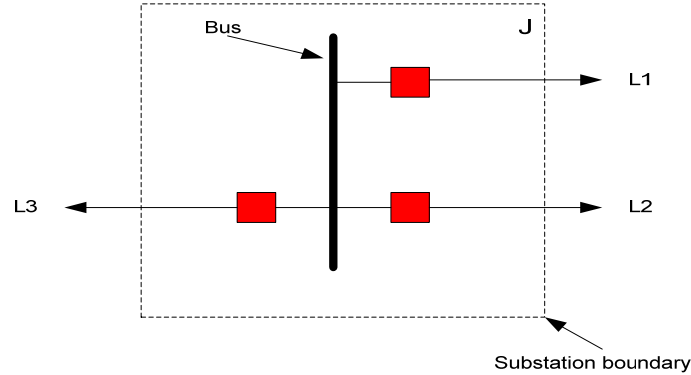

Fault on the Bus at 6:00 PM 4/29/2008 GMT (UTC)

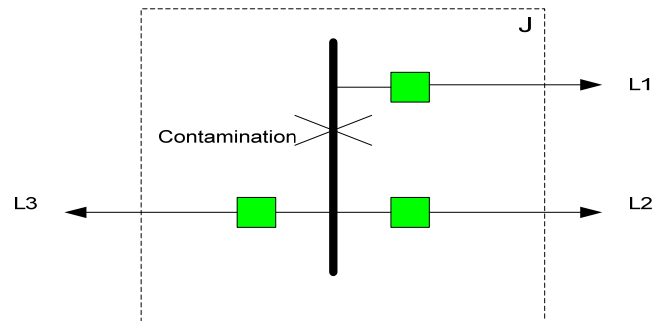

Individual outages are over when corresponding line breakers are placed in-service  
Breakers for L1 and L2 were closed at 6:20 PM 04/29/2008 GMT (UTC)  
Breaker for L3 was closed at 7:00 PM 4/29/2008 GMT (UTC)

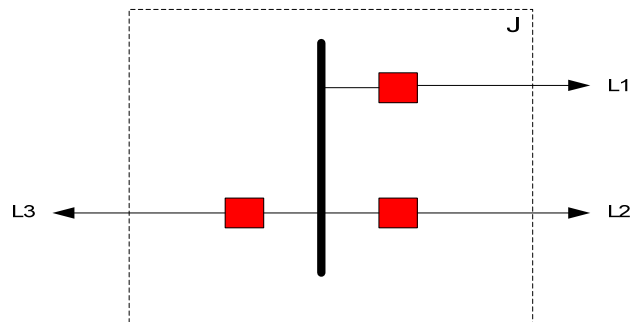

An outage of a 345 kV straight bus: An outage to any of the AC Circuits connected to the bus is reportable.

Outage Mode: Common Mode Outage

These are Common Mode Outages because the outages are not the consequence of any single TADS Element.

## AC Circuit that is directly connected to a TADS Transformer

Example: Event ID Code D-2008, Outage ID Codes D1 & D2

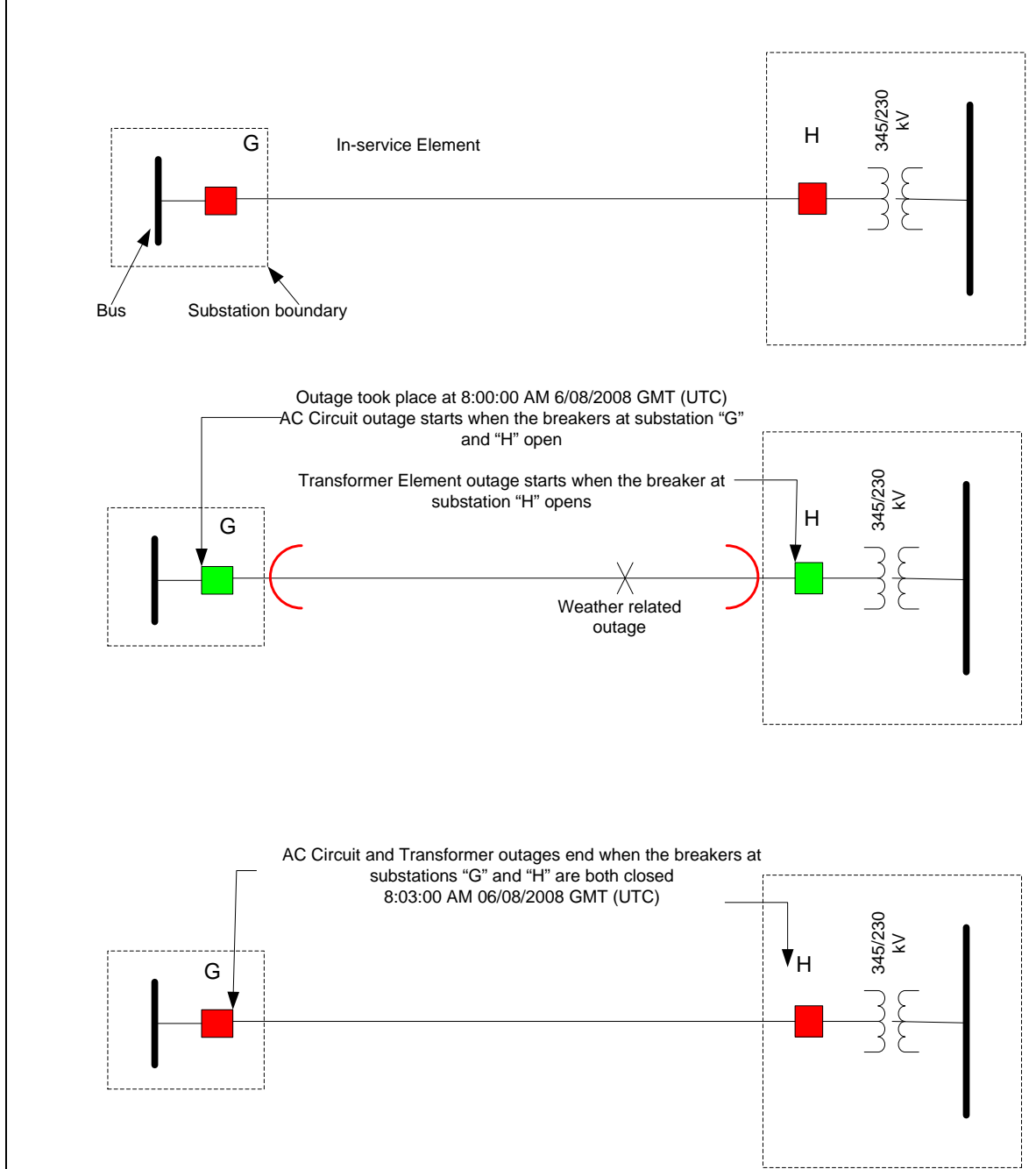

Outage Mode: Dependent Mode Initiating Outage (For the AC Circuit)

Outage Mode: Dependent Mode Outage (For the Transformer)

This is a Dependent Mode Outage because the outage of the transformer is due to the outage of the AC Circuit.

## Three-terminal AC Circuit

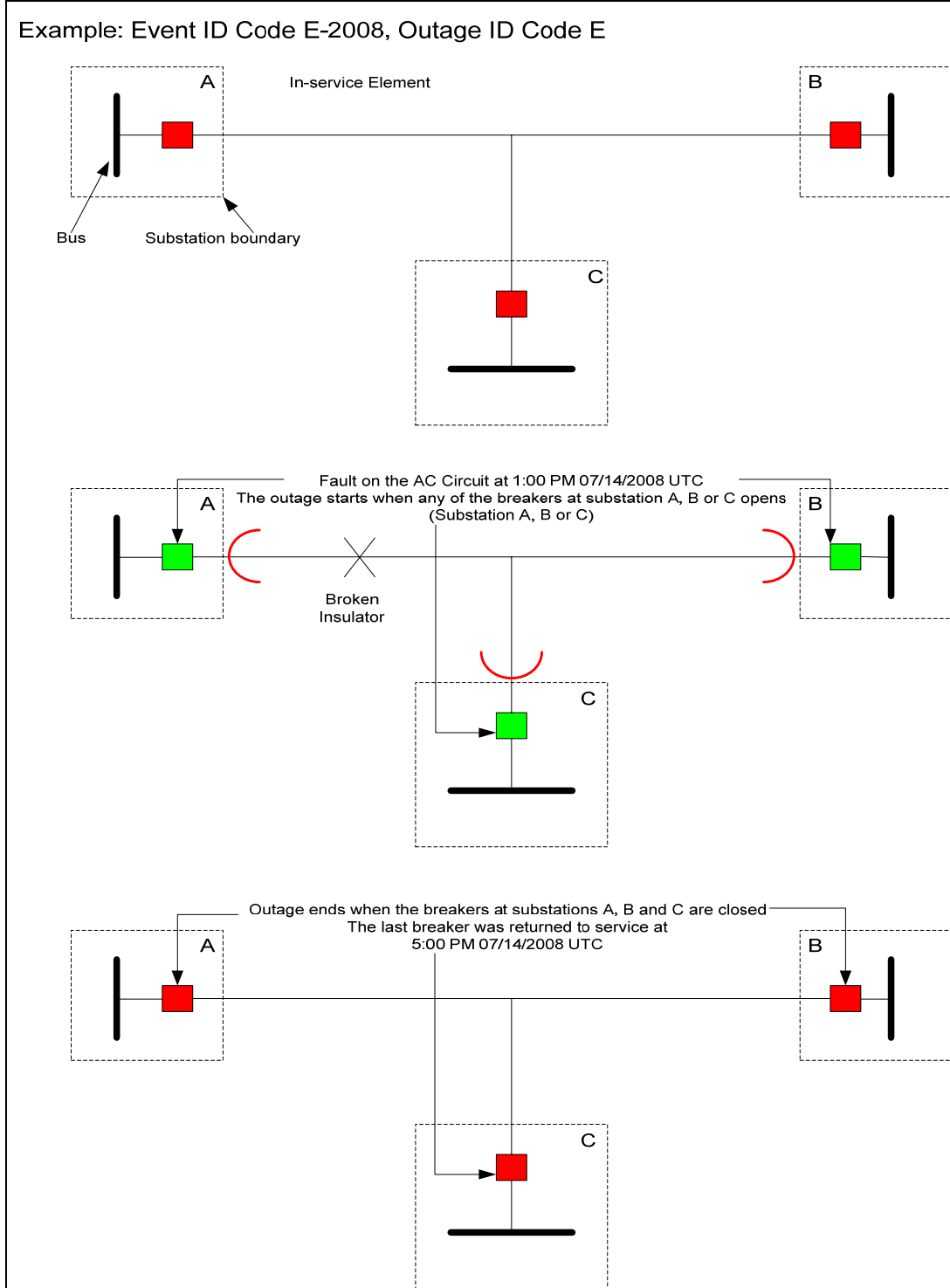

Outage Mode: Single Mode Outage

No other TADS Elements were impacted with this outage.

## Common cause outage to two AC Circuits

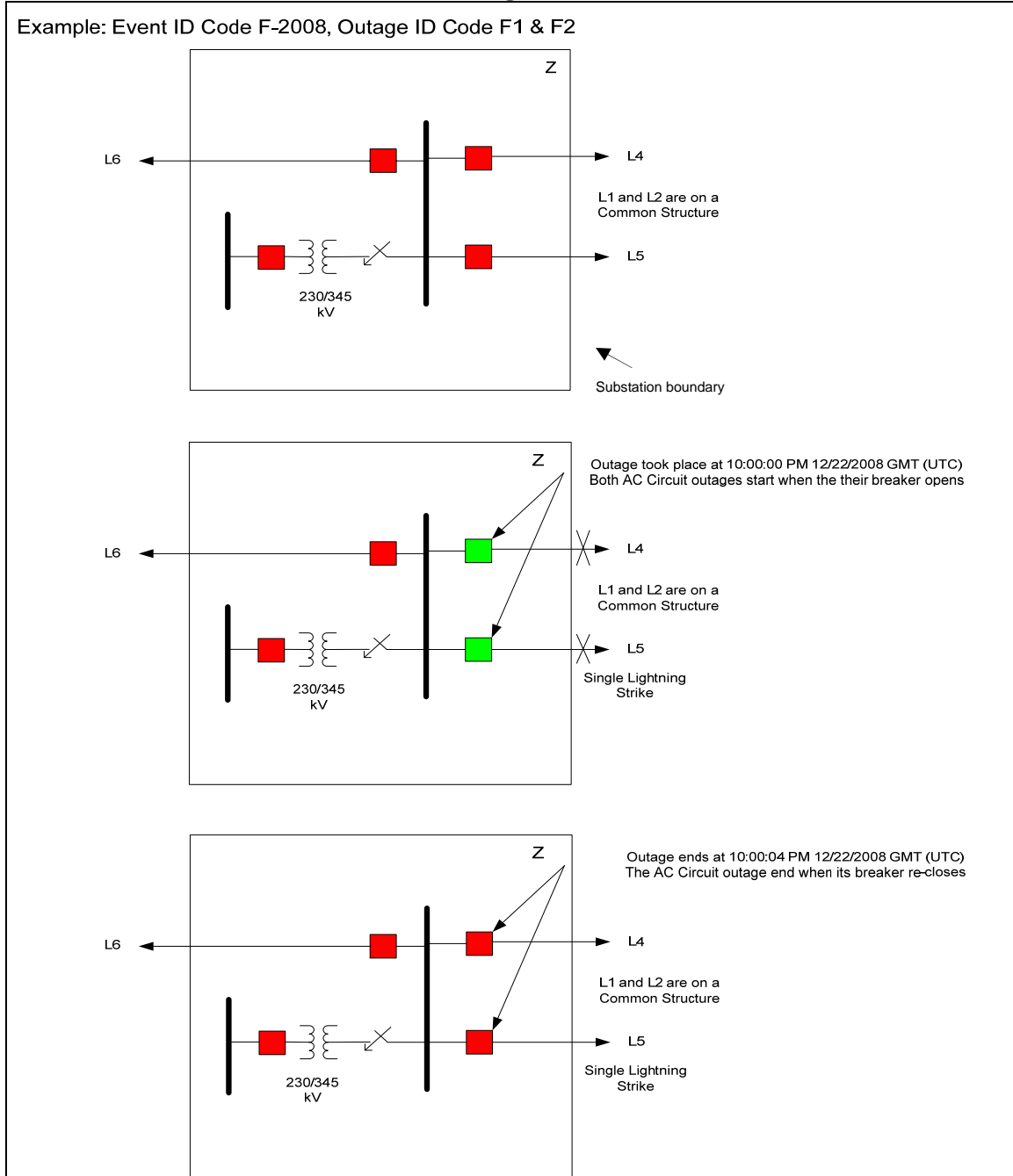

### Outage Mode: Common Mode Outage

A single lightning strike cause both lines to open. The outage on either TADS Element was not a consequence of each other.

## Transformer outage

Example: Event ID Code G-2008, Outage ID Code G

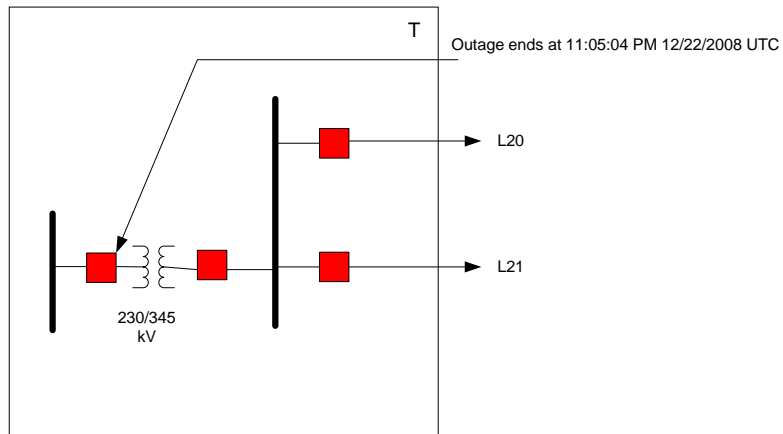
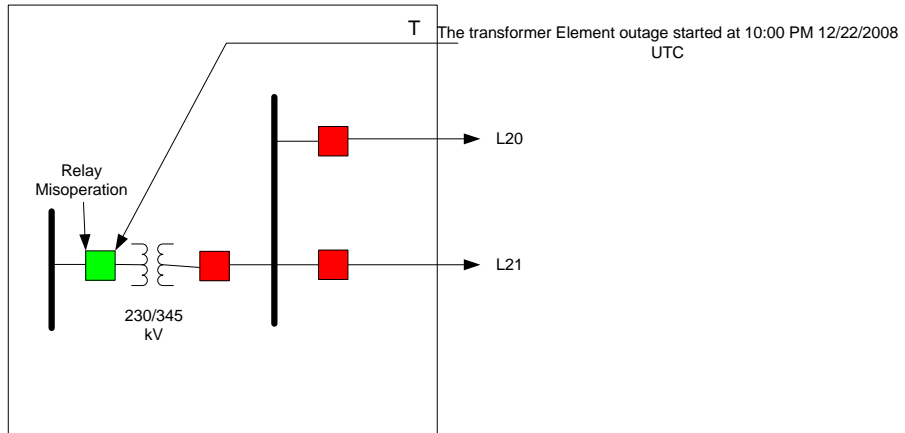
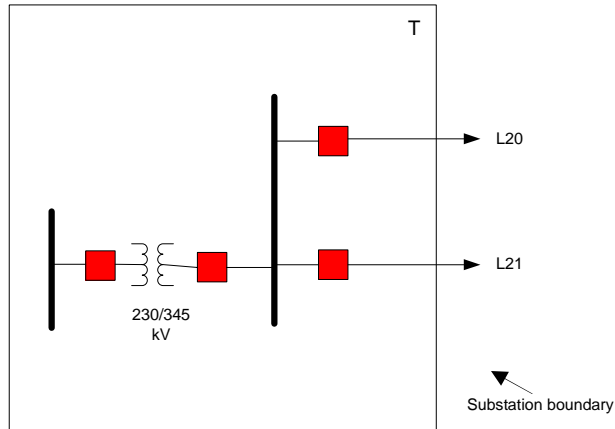

Outage Mode: Single Mode Outage

No other TADS Elements were outage because of the relay misoperation.

## AC Circuit outage with a breaker failure

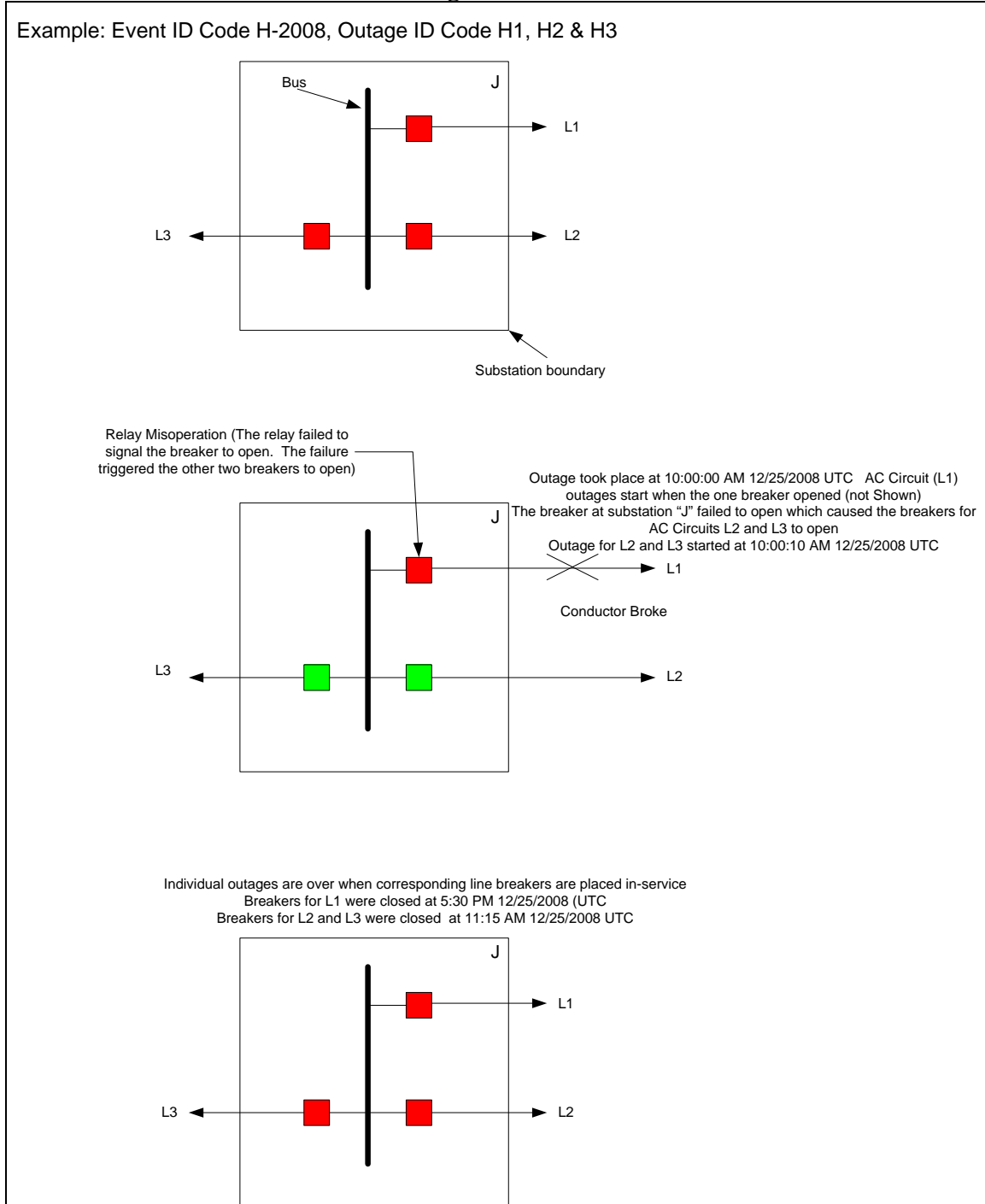

Outage Mode: Dependent Mode Initiating Outage (For L1)

Outage Mode: Dependent Mode Outage (For L2 and L3)

The outages on AC Circuits L2 and L3 were due to the relay misoperation for the breaker on L1. If the breaker for L1 had not failed the breakers for L3 and L2 would not have opened.

### Form 4.1 AC Circuit Detailed Automatic Outage Data

AC Circuit Momentary and Sustained Outage Data															
(A) Outage ID Code	(B) Event ID Code [2]	(C) Voltage Class	Circuit Substation Boundaries			(G) TO Element Identifier (AC Circuit)	(H) OH or UG?	(I) AC Multi-Owner Com. Struct. Flag [3]	(J) Fault Type	(K) Outage Initiation Code	(L) Start Time (dd/mm/yyyy hh:mm) (UTC)	(M) Outage Duration hh:mm [5]	Cause Codes		(P) Outage Mode
			(D) AC Substation Name #1	(E) AC Substation Name #2	(F) AC Substation Name #3								(N) Initiating Cause Code [6]	(O) Sustained Cause Code [7]	
A	A-2008	300-399 kV	D	E	F	345-DEF	OH	0	Ground target	Element-Initiated	2/3/2008 11:00	7:00	Failed AC Circuit Equipment	Failed AC Circuit Equipment	Single Mode
B1	B-2008	300-399 kV	M	N	O	345-MNO	OH	0	Ground target	Element-Initiated	2/5/2008 11:00	5:00	Failed AC Circuit Equipment	Failed AC Circuit Equipment	Dependent Mode
C1	C-2008	300-399 kV	J	K		345-JK	OH	0	Ground target	AC Substation-Initiated	4/29/2008 18:00	0:20	Contamination	Contamination	Initiating Common Mode
C2	C-2008	300-399 kV	J	Q		345-JQ	OH	0	Ground target	AC Substation-Initiated	4/29/2008 18:00	0:20	Contamination	Contamination	Common Mode
C3	C-2008	300-399 kV	J	X		3345-JX	OH	0	Ground target	AC Substation-Initiated	4/29/2008 18:00	1:00	Contamination	Contamination	Common Mode
D1	D-2008	300-399 kV	G	H		345-GH	OH	0	Phase target	Element-Initiated	6/8/2008 8:00	0:03	Weather, excluding lightning	Weather, excluding lightning	Dependent Mode
E	E-2008	300-399 kV	A	B	C	345-ABC	OH	0	Phase target	Element-Initiated	7/14/2008 13:00	4:00	Failed AC Circuit Equipment	Failed AC Circuit Equipment	Single Mode
F1	F-2008	300-399 kV	Z	W		345-ZW	OH	0	Ground target	Element-Initiated	12/22/2008 22:00	0:00	Lightning	NA- Momentary	Common Mode
F2	F-2008	300-399 kV	Z	Y		345-ZY	OH	0	Ground target	Element-Initiated	12/22/2008 22:00	0:00	Lightning	NA- Momentary	Common Mode
H1	H-2008	300-399 kV	J	K		345-JK	OH	0	Phase target	Element-Initiated	12/25/2008 10:00	7:30	Failed AC Circuit Equipment	Failed AC Circuit Equipment	Dependent Mode
H2	H-2008	300-399 kV	J	Q		345-JQ	OH	0	Phase target	Other Facility-Initiated	12/25/2008 10:00	1:15	Failed Protection System Equipment	Failed Protection System Equipment	Dependent Mode
H3	H-2008	300-399 kV	J	X		3345-JX	OH	0	Phase target	Other Facility-Initiated	12/25/2008 10:00	1:15	Failed Protection System Equipment	Failed Protection System Equipment	Dependent Mode

### Form 4.3 Transformer Detailed Automatic Outage Data

Transformer Momentary and Sustained Outage Data															
(A) Outage ID Code	(B) Event ID Code [2]	(C) High-Side Voltage Class	(D) Located at (AC Sub. Name)	(E)	(F)	(G) TO Element Identifier (Transformer)	(H)	(I)	(J) Fault Type	(K) Outage Initiation Code	(L) Start Time (dd/mm/yyyy hh:mm) (UTC)	(M) Outage Duration hh:mm [4]	Cause Codes		(P) Outage Mode
													(N) Initiating Cause Code [5]	(O) Sustained Cause Code [6]	
B2	B-2008	300-399 kV	O	NA	NA	xtrm #1-O	NA	NA	No fault	Other Element-Initiated	2/5/2008 11:00	5:30	Failed AC Circuit Equipment	Failed AC Circuit Equipment	Dependent Mode
D2	D-2008	300-399 kV	H	NA	NA	xtrm #1-H	NA	NA	No fault	Other Element-Initiated	6/8/2008 8:00	0:03	Weather, excluding lightning	Weather, excluding lightning	Dependent Mode
G	G-2008	300-399 kV	T	NA	NA	xtrm #1-T	NA	NA	No fault	Other Facility-Initiated	12/22/2008 22:00	1:05	Failed Protection System Equipment	Failed Protection System Equipment	Single Mode

**Form 5 Event ID Code**

Event Type No.	Table 1 Category from the TPL Standards	Description			
10	B	Automatic Outage of an AC Circuit or Transformer with Normal Clearing.			
20	B	Automatic Outage of a DC Circuit with Normal Clearing.			
30	C	Automatic Outage of two ADJACENT AC Circuits on common structures with Normal Clearing.			
40	C	Automatic Outage of two ADJACENT DC Circuits on the common structures with Normal Clearing.			
50	NA	Other - please describe the event (optional)			
<b>Event ID Code Data</b>					
(A) Event ID Code	(B) Event Type No. [2]	(C) Description of Event Type No. 50 (Other) [3]	(D) Disturbance Report Filed [4]		
A-2008	10		No		
B-2008	50	Outage of Transmission Line and Transformer	No		
C-2008	50	Bus Outage	No		
D-2008	50	Outage of Transmission Line and Transformer	No		
E-2008	10		No		
F-2008	30		No		
G-2008	10		No		
H-2008	50	Fault on a Transmission Line followed by a system protection failure	No		

## Appendix 9 Regional Entity and NERC Contacts

Regional Entity contacts will be provided.

Florida Reliability Coordinating Council (FRCC)  
Midwest Reliability Organization (MRO)  
Northeast Power Coordinating Council (NPCC)  
ReliabilityFirst Corporation (RFC)  
SERC Reliability Corporation (SERC)  
Southwest Power Pool, Inc. (SPP)  
Texas Regional Entity (TRE)  
Western Electricity Coordinating Council (WECC)

NERC contact:

~~John Seelke~~ [Jim Robinson](#)

E-mail: [john.seelkejim.robinson@nerc.net](mailto:john.seelkejim.robinson@nerc.net)

~~Allentown, PA~~ Office: ~~609-452-8060~~ [610-841-3362](tel:610-841-3362)

Mobile: ~~609-273-0837~~ [610-597-7994](tel:610-597-7994)

