

NERC

NORTH AMERICAN ELECTRIC
RELIABILITY CORPORATION

Transmission Availability Data System (TADS) DEFINITIONS

Draft May 10, 2010

for Proposed Event Type Numbers

to ensure
the reliability of the
bulk power system

Table of Contents

A.	TADS Population Definitions.....	3
1.	Element	3
2.	Protection System	3
3.	AC Circuit	3
4.	Transformer	5
5.	AC Substation	5
6.	AC/DC Terminal.....	5
7.	AC/DC Back-to-Back Converter	5
8.	DC Circuit	5
9.	Overhead Circuit	5
10.	Underground Circuit	5
11.	Circuit Mile	5
12.	Multi-Circuit Structure Mile	6
13.	Voltage Class	6
B.	Outage Reporting Definitions.....	6
1.	Automatic Outage	6
2.	Momentary Outage.....	6
3.	Sustained Outage.....	6
4.	Non-Automatic Outage	7
5.	Planned Outage	7
6.	Operational Outage	7
7.	AC Multi-Owner Common Structure Flag.....	7
8.	In-Service State	7
9.	Substation, Terminal, or Converter Name	10
10.	TO Element Identifier	10
11.	Outage Start Time	10
12.	Outage Duration.....	10
13.	Outage Continuation Flag	10
14.	Outage Identification (ID) Code	11
15.	Normal Clearing.....	11
16.	Normal Clearing Circuit Breaker Set (NCCBS)	11
17.	Abnormal Clearing.....	12
18.	Delayed Fault Clearing	12
19.	Special Protection System (SPS) or Remedial Action Scheme (RAS).....	12
20.	Event	13
21.	Event Identification (ID) Code.....	13
22.	Event Type Number	13
23.	Fault Type	16
C.	Outage Initiation Codes	18
1.	Element-Initiated Outage	18
2.	Other Element-Initiated Outage	18
3.	AC Substation-Initiated Outage	18
4.	AC/DC Terminal-Initiated Outage.....	18
5.	Other Facility-Initiated Outage	18
D.	Outage Mode Codes	19
1.	Single Mode Outage.....	19
2.	Dependent Mode Initiating Outage.....	19
3.	Dependent Mode Outage.....	19

4.	Common Mode Outage.....	19
5.	Common Mode Initiating Outage	19
E.	Automatic Outage Cause Code Types.....	20
1.	Initiating Cause Code.....	20
2.	Sustained Cause Code.....	20
F.	Automatic Outage Cause Codes	21
1.	Weather, excluding lightning.....	21
2.	Lightning.....	21
3.	Environmental.....	21
4.	Contamination.....	21
5.	Foreign Interference.....	21
6.	Fire	21
7.	Vandalism, Terrorism or Malicious Acts.....	21
8.	Failed AC Substation Equipment.....	21
9.	Failed AC/DC Terminal Equipment	21
10.	Failed Protection System Equipment.....	21
11.	Failed AC Circuit Equipment.....	22
12.	Failed DC Circuit Equipment.....	22
13.	Vegetation	22
14.	Power System Condition.....	22
15.	Human Error	22
16.	Unknown.....	22
17.	Other.....	23
G.	Planned Outage Cause Codes	23
1.	Maintenance and Construction.....	23
2.	Third-Party Requests.....	23
3.	Other Planned Outage	23
H.	Operational Outage Cause Codes	23
1.	Emergency	23
2.	System Voltage Limit Mitigation.....	23
3.	System Operating Limit Mitigation, excluding System Voltage Limit Mitigation.....	23
4.	Other Operational Outage	24

A. TADS Population Definitions

1. Element

The following are Elements for which TADS data are to be collected:

1. AC Circuits ≥ 200 kV (Overhead and Underground)
2. Transformers with ≥ 200 kV low-side voltage
3. AC/DC Back-to-Back Converters with ≥ 200 kV AC voltage, both sides
4. DC Circuits with $\geq +/-200$ kV DC voltage

An Element may also be referred to as a “TADS Element” in the Manual. They have the same meaning.

2. Protection System

Protective relays, associated communication systems, voltage and current sensing devices, station batteries and DC control circuitry.¹

3. AC Circuit

A set of AC overhead or underground three-phase conductors that are bound by AC Substations. Radial circuits are AC Circuits.

The boundary of an AC Circuit extends to the transmission side of an AC Substation. A circuit breaker, Transformer, and their associated disconnect switches are not considered part of the AC Circuit but instead are defined as part of the AC Substation. The AC Circuit includes the conductor, transmission structure, joints and dead-ends, insulators, ground wire, and other hardware, including in-line switches. The AC Circuit includes in-line switches used to sectionalize portions of the AC Circuit as well as series compensation (capacitors and reactors) that is within the boundaries of the AC Circuit even if these ‘in-line’ devices are within an AC Substation. If these devices are not within the AC Circuit boundaries, they are not part of the AC Circuit but instead are part of the AC Substation. The diagrams on the next several pages explain this concept. The red arcs define the AC Circuit boundaries.²

In Figure 1 (next page), the series capacitor, bypass circuit breaker, and numerous disconnect switches are in a fenced AC Substation that is within the boundaries of the AC Circuit itself. When the series capacitor is connected and the bypass breaker is open, the capacitor and its disconnect switches are part of the AC Circuit. When the bypass breaker is closed, the bypass breaker and its disconnect switches (not shown) are part of the AC Circuit.

¹ This definition is in the current NERC *Glossary of Terms Used in Reliability Standards*.

² To simplify future diagrams, disconnect switches may not be shown.

Figure 1

Two in-line NC switches and one series capacitor are part of the AC Circuit between AC Substations A and B. When the bypass breaker and its disconnect switches (not shown) are closed and the capacitor switches opened, the breaker and its switches are part of the AC Circuit.

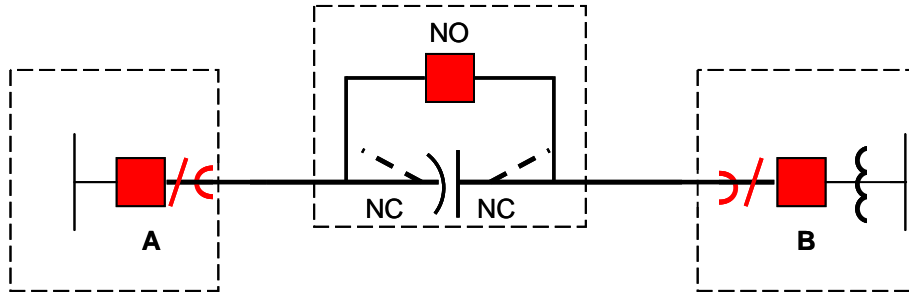

In Figure 2, the series reactor and in-line switches are part of the AC Circuit since they are within the AC Circuit boundaries even though they are within the AC Substation boundaries. In Figure 3, they are not part of the AC Circuit because they are not within the AC Circuit boundaries.

Figure 2

Two in-line NC switch and one series reactor are part of the AC Circuit between AC Substations A and B. The AC Circuit boundaries are the breaker disconnect switch in AC Substation A and the high-side disconnect switch on the Transformer in AC Substation B.

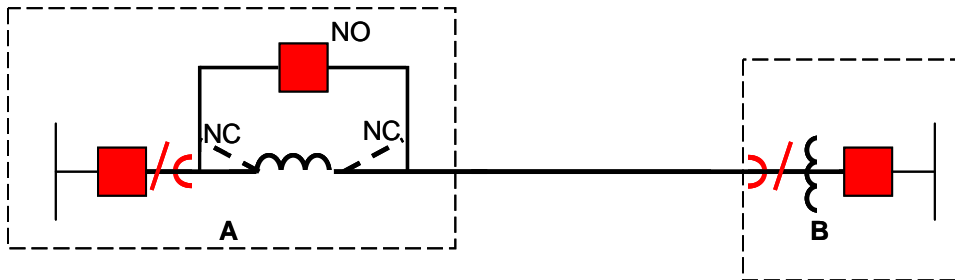
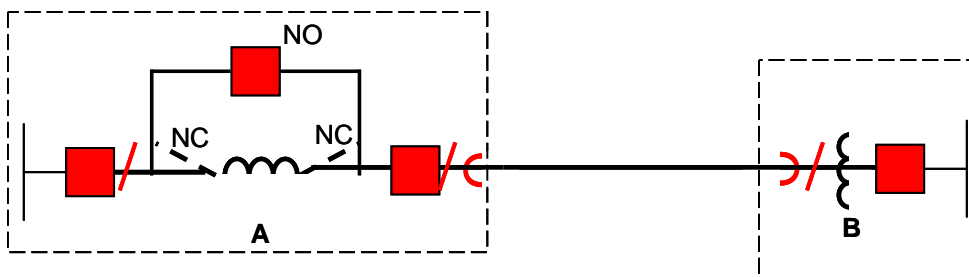

Figure 3

Two in-line NC switches and one series reactor are part of the AC Substation and not part of the AC Circuit between AC Substations A and B



4. Transformer

A bank comprised of three single-phase transformers or a single three-phase transformer. A Transformer is bounded by its associated switching or interrupting devices.

5. AC Substation

An AC Substation includes the circuit breakers and disconnect switches which define the boundaries of an AC Circuit, as well as other facilities such as surge arrestors, buses, Transformers, wave traps, motorized devices, grounding switches, and shunt capacitors and reactors. Series compensation (capacitors and reactors) is part of the AC Substation if it is not part of the AC Circuit. See the explanation in the definition of “AC Circuit.” Protection System equipment is excluded.

6. AC/DC Terminal

A terminal that includes all AC and DC equipment needed for DC operation such as PLC (power-line carrier) filters, AC filters, reactors and capacitors, Transformers, DC valves, smoothing reactors and DC filters. On the AC side, an AC/DC Terminal is normally bound by AC breakers at the AC Substation bus where it is connected. On the DC side, it is bound by DC converters and filters. Protection System equipment is excluded.

7. AC/DC Back-to-Back Converter

Two AC/DC Terminals in the same location with a DC bus between them. The boundaries are the AC breakers on each side.

8. DC Circuit

One pole of an Overhead or Underground DC line which is bound by an AC/DC Terminal on each end.

9. Overhead Circuit

An AC or DC Circuit that is not an Underground Circuit. A cable conductor AC or DC Circuit inside a conduit which is *not* below the surface is an Overhead Circuit. A circuit that is part Overhead and part Underground is to be classified based upon the majority characteristic (Overhead Circuit or Underground Circuit) using Circuit Miles.

10. Underground Circuit

An AC or DC Circuit that is below the surface, either below ground or below water. A circuit that is part Overhead Circuit and part Underground Circuit is to be classified based upon the majority characteristic (Overhead Circuit or Underground Circuit) using Circuit Miles.

11. Circuit Mile

One mile of either a set of AC three-phase conductors in an Overhead or Underground AC Circuit, or one pole of a DC Circuit. A one mile-long, AC Circuit tower line that carries two three-phase circuits (i.e., a double-circuit tower line) would equate to two Circuit Miles. A one mile-long, DC tower line that carries two DC poles would equate to two Circuit Miles. Also, a one mile-long, common-trenched, double-AC Circuit Underground duct bank that carries two three-phase circuits would equate to two Circuit Miles.

12. Multi-Circuit Structure Mile

A one-mile linear distance of sequential structures carrying multiple Overhead AC or DC Circuits. (Note: this definition is *not* the same as the industry term “structure mile.” A Transmission Owner’s Multi-Circuit Structure Miles will generally be less than its structure miles since not all structures contain multiple circuits.)

If a line section contains two or more Multi-Circuit Structures which form one or more multi-circuit spans, the total span length can be measured and the associated mileage should be reported in the ‘Multi-Circuit Structure Mile’ total inventory. If multiple circuits are connected to only one common structure, that structure should be ignored for outage and inventory mileage purposes.

13. Voltage Class

The following voltages classes will be used for reporting purposes:

1. 200 – 299 kV
2. 300 – 399 kV
3. 400 – 499 kV
4. 500 – 599 kV
5. 600 – 799 kV

For Transformers, the Voltage Class reported will be the high-side voltage, even though the cut-off voltage used in the definition is referenced on the low-side. Voltages are operating voltages.

B. Outage Reporting Definitions

1. Automatic Outage

An outage which results from the automatic operation of switching device, causing an Element to change from an In-Service State to a not In-Service State. A successful AC single-pole (phase) reclosing event is not an Automatic Outage.

2. Momentary Outage

An Automatic Outage with an Outage Duration less than one (1) minute. If the circuit recloses and trips again within less than a minute of the initial outage, it is only considered one outage. The circuit would need to remain in service for longer than one minute between the breaker operations to be considered as two outages.

3. Sustained Outage³

An Automatic Outage with an Outage Duration of a minute or greater.

³ The TADS definition of Sustained Outage is different than the NERC *Glossary of Term Used in Reliability Standards* definition of Sustained Outage which is presently only used in FAC-003-1. The glossary defines a Sustained Outage as follows: “The deenergized condition of a transmission line resulting from a fault or disturbance following an unsuccessful automatic reclosing sequence and/or unsuccessful manual reclosing procedure.” The definition is inadequate for TADS reporting for two reasons. First, it has no time limit that would distinguish a Sustained Outage from a Momentary Outage. Second, for a circuit with no automatic reclosing, the outage would not be “counted” if the TO has a successful manual reclosing under the glossary definition.

4. Non-Automatic Outage

An outage which results from the manual operation (including supervisory control) of a switching device, causing an Element to change from an In-Service State to a not In-Service State.

5. Planned Outage

A Non-Automatic Outage with advance notice for the purpose of maintenance, construction, inspection, testing, or planned activities by third parties that may be deferred. Outages of TADS Elements of 30 minutes or less duration resulting from switching steps or sequences that are performed in preparation or restoration of an outage of another TADS Element are not reportable.

6. Operational Outage

A Non-Automatic Outage for the purpose of avoiding an emergency (i.e., risk to human life, damage to equipment, damage to property) or to maintain the system within operational limits and that cannot be deferred.

7. AC Multi-Owner Common Structure Flag

This flag identifies whether the outaged AC Circuit is on common structures with another circuit that is owned by a different Transmission Owner. This flag does not apply to DC Circuits which by default are all assumed to be on common structures with the circuits owned by the same Transmission Owner.

<u>Flag</u>	<u>Flag Interpretation</u>
-------------	----------------------------

- | | |
|---|---|
| 0 | Not applicable. The circuit is not on common structures with another circuit, or the circuit is on common structures, but all circuits are reported by the same Transmission Owner. No analysis of the Event ID Code or the Event Type Number is required by the Regional Entity. |
| 1 | Circuit is on common structures with another circuit that is being reported by a different Transmission Owner. The Regional Entity will need to examine Outage Start Times with this same flag to determine whether a second circuit had an outage with nearly the same Outage Start Time, and if so, whether the TOs properly coordinated their Event ID Codes and Event Type Numbers. |

8. In-Service State

An Element that is energized and connected at all its terminals to the system. Examples of reportable AC Circuit and Transformer Automatic Outages are illustrated below. Non-Automatic Outage examples are in Appendix 10.

In Figure 4, AC Circuit A is bound by the disconnect switches (not shown)⁴ of two breakers, and Transformer A is bound by a breaker and a disconnect switch. AC Circuit B is bound by a breaker and a disconnect switch, and Transformer B is bound by a breaker and a disconnect switch. 230 kV bus fault opens the green breakers. The TADS Transformers each report an outage. AC Circuit A reports an outage, but AC Circuit B

⁴ For simplification, disconnect switches may not be show in some figures. When a circuit breaker or Transformer disconnect switch define an AC Circuit boundary, we may just refer to the circuit breaker and the Transformer as defining the boundary without reference to their disconnect switches.

does not. It is defined by the breaker on the left and the disconnect switch on the right. Since the breaker associated with AC Circuit B did not experience an automatic operation, it was not outaged. It remains connected at all its terminals by the breaker and the disconnect switch.

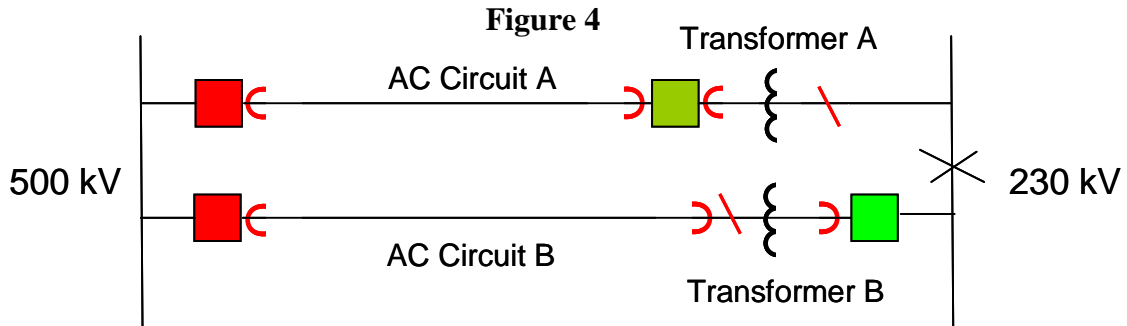

In Figure 5, we have a similar situation, except that the Transformers are not reportable since their low-side voltages are less than 200 kV. The AC Circuit outages are reportable exactly the same as in Figure 4; however, the Transformer outages are not reportable.

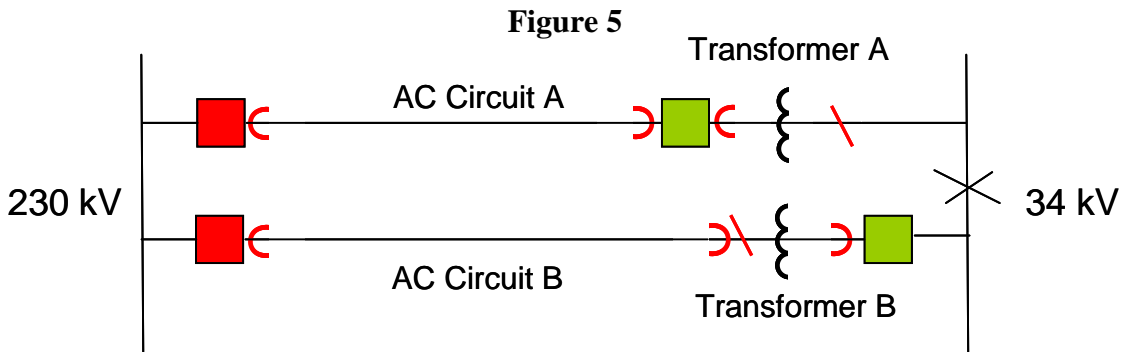

In Figure 6 (next page), AC Circuit 22, the only source connecting AC Substations A and B, has a fault. As a result, AC Circuits 84 and 88 are deenergized but remain connected at all their terminals. Three outages are reported: circuits 22, 84, and 88. None of them meet the In-Service State requirement of being energized *and* connected at all their terminals.

Figure 6

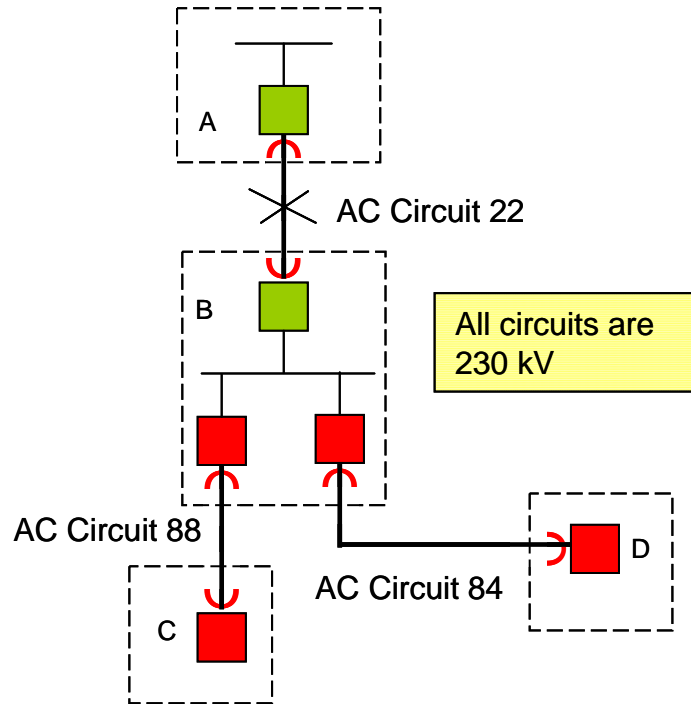

An exception that an Element be “connected at all its terminals” to be considered in an In-Service State is provided for a multi-terminal AC Circuit with a Transformer on one terminal that shares a breaker with the circuit.

Figure 7

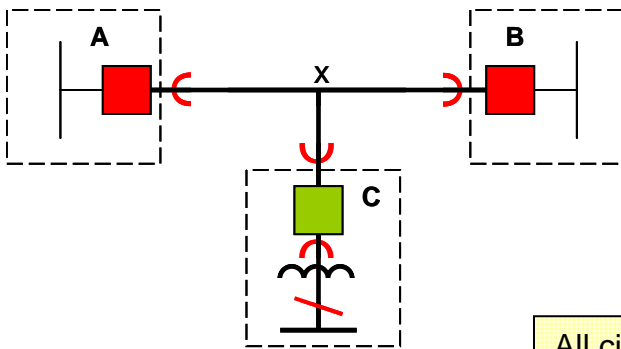
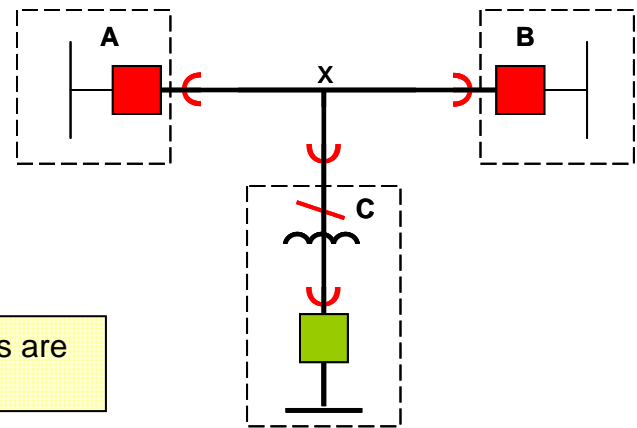

Figure 8



In both figures, the AC Circuit is bounded by AC Substations “A,” “B,” and “C” as indicated by the red arcs. Each Transformer’s boundaries are the red disconnect switch and the red arc before the breaker. Note that the Transformer in either figure may *or* may not be a reportable Element (i.e., one with a low-side voltage ≥ 200 kV).

Assume that each Transformer is out of service as a result of the operation of its associated breaker (indicated in green). In Figure 7, the AC Circuit would normally be considered out of service since the breaker at AC Substation C, which is shared by the AC Circuit and the Transformer, is open. Nevertheless, if all other portions of the AC Circuit are in service, the entire AC Circuit is considered to be in an In-Service State even if the Transformer is out of service. Because TADS does not recognize partial outage states, the multi-terminal exception above was developed so as to not overstate the outage contribution of a multi-terminal configuration of this type. In Figure 8, the open breaker is not shared by the AC Circuit, and the AC Circuit remains connected. Thus, the exception does not apply in this case since the AC Circuit is connected at all its terminals even though the Transformer is out of service.

9. Substation, Terminal, or Converter Name

For Automatic Outages or Non-Automatic Outages of AC Circuits and DC Circuits, the termination name at each end of the circuit will be reported to help identify *where* the circuit is located. For AC Circuits, these are the AC Substation Names; for DC Circuits, these are the AC/DC Terminal Names. For AC/DC Back-to-Back Converters, this is the Converter Station Name.

10. TO Element Identifier

An alphanumeric name that the TO must enter to identify the Element which is outaged (e.g., a circuit name.)

11. Outage Start Time

The date (mm/dd/yyyy) and time (hhhh:mm), rounded to the minute, that the Automatic Outage or Non-Automatic Outage of an Element started. Outage Start Time may be expressed in Coordinated Universal Time (UTC) or in local time. TADS data is reported on a calendar-year basis, and the *TADS Data Reporting Instruction Manual* addresses the recording of the Outage Start time of a Sustained Outage or Non-Automatic Outage that starts in one reporting year and concludes in another reporting year.

12. Outage Duration

The amount of time from the Outage Start Time to when the Element is restored to an In-Service State. Outage Duration is expressed as hours and minutes, rounded to the nearest minute. Momentary Outages are assigned a time of zero Outage Duration. TADS data is reported on a calendar-year basis, and the *TADS Data Reporting Instruction Manual* addresses the recording of the Outage Durations of an outage that starts in one reporting year and concludes in another reporting year.

13. Outage Continuation Flag

Not all outages start and end in the same reporting year. This flag describes that characteristic for an outage.

<u>Flag</u>	<u>Flag Interpretation</u>
0	Outage began and ended within the reporting year
1	Outage began in the reporting year but continues into the next reporting year.
2	Outage started in another (previous) reporting year.

14. Outage Identification (ID) Code

A unique alphanumeric identifier assigned by the Transmission Owner to identify the reported outage of an Element.

15. Normal Clearing

NERC Glossary definition: “A Protection System⁵ operates as designed, and the fault is cleared [by the NCCBS defined below] in the time normally expected with proper functioning of the installed Protection System” [clarification added in brackets]. For TADS purposes, Normal Clearing also includes a Protection System operating as designed for a non-fault condition where an Automatic Outage occurs as expected with proper functioning of the installed Protection System. The Normal Clearing definition applies to the opening of circuit breakers. Subsequent automatic reclosing by the Protection System is not included in the Normal Clearing time frame.

An example of a Normal Clearing event where the reclosing did not function properly would be;

An AC Circuit is struck by lightning (with no damage to the equipment) and the Protection System clears the fault as designed (Normal Clearing). However, the Protection System automatic reclosing equipment fails to re-energize the AC Circuit. It was expected that the breakers would reclose and return the line to an In-Service State. Even though the Protection System failed to reclose properly, the above sequence of events is still an example of Normal Clearing as defined above.

16. Normal Clearing Circuit Breaker Set (NCCBS)

The set of circuit breakers that would open to isolate a fault on a given Element under Normal Clearing.

For each Element by design, a given set of circuit breakers trip in order to interrupt fault current (if a fault occurred on the Element). In general, this set of circuit breakers may be determined by examining an elementary single line diagram of the circuit which includes the TADS defined Element. Please note when this given set of circuit breakers open, two or more Elements may change to a not In-Service State and therefore become reportable Automatic Outages. In such a case these Outages are reportable as one Event, and the same Event ID should be used for each of the Outages.

For example see the above Figure 8. For purposes of this example, the 230kV AC Circuit is tapped by a 230/69kV transformer which has a low side 69kV circuit breaker. However, as shown on Figure 8 the transformer does not have a high side 230kV circuit breaker. In such a case the NCCBS for this TADS 230kV AC Circuit includes the 69kV circuit breaker as part of the expected Normal Clearing if a fault occurs on the TADS Element. The three circuit breakers shown on Figure 8 are the NCCBS including the 69kV circuit breaker.

⁵ This definition is in the current NERC *Glossary of Terms Used in Reliability Standards*. Although the term “protection system” is not capitalized in the *Glossary*, we have capitalized it here because we believe it has the same meaning.

17. Abnormal Clearing

The outage of a TADS Element that does not conform with Normal Clearing in all aspects.

For a given Event ID and its associated Automatic Outages, an Automatic Outage which results from one or more unintended 200kV or above circuit breaker operations outside the NCCBS should be categorized as Abnormal Clearing.

Example Event ID 17A: See the above Figure 6. The NCCBS for “AC Circuit 22” is circuit breaker A and circuit breaker B. During an event where an Automatic Outage of “AC Circuit 22” occurs, if 230kV circuit breaker D also trips, the Automatic Outage of “AC Circuit 84” is the result of Abnormal Clearing. Since one of the Automatic Outages is the result of Abnormal Clearing, Event ID 17A is an Abnormal Clearing event.

Example Event ID 17B: On the contrary, during an event where an Automatic Outage of “AC Circuit 22” occurs (Figure 6), if the 69kV circuit breaker C on Figure 8 also trips, the 230/69kV transformer outage is not a reportable Automatic Outage. Since the only Automatic Outage is “AC Circuit 22” and it is the result of Normal Clearing, Event ID 17B is a Normal Clearing event.

Improper operation of Protection System automatic reclosing is not considered to be Abnormal Clearing. Reclosing is a separate function and occurs after circuit breaker clearing.

Delayed Fault Clearing is considered to be Abnormal Clearing. See definition 18 below.

18. Delayed Fault Clearing

Fault clearing consistent with correct operation of a breaker failure Protection System and its associated breakers, or of a backup Protection System with an intentional time delay.⁷

Example Event ID 18A: See Figure 6. For the purpose of this example the correct operation of the Protection System for “AC Circuit 22” normally clears both circuit breakers A and B in less than 4 cycles. However, if the primary Protection System fails (no primary relay targets) and the backup Protection System operates (with an intentional time delay relay target) then this Automatic Outage includes Delayed Fault Clearing. Since the Automatic Outage includes Delayed Fault Clearing, Event ID 18A is an Abnormal Clearing event.

19. Special Protection System (SPS) or Remedial Action Scheme (RAS)

“An automatic Protection System designed to detect abnormal or predetermined system conditions, and take corrective actions other than and/or in addition to the isolation of faulted components to maintain system reliability. Such action may include changes in demand, generation (MW and Mvar), or system configuration to maintain system stability, acceptable voltage, or power flows. An SPS does not include (a) underfrequency or undervoltage load shedding or (b) fault conditions that must be isolated or (c) out-of-step relaying (not designed as an integral part of an SPS). Also called Remedial Action Scheme.”

The above definition is from the NERC Glossary of Terms. As designed a SPS or RAS may normally trip additional circuit breakers beyond the NCCBS. For a given Event ID and its associated Automatic Outages, an Event which results from one or more expected SPS or RAS normal operations should be categorized as Event Type #49 (Other Normal Clearing). Abnormal SPS or RAS operations should be categorized as Event Type #90 (Other Abnormal Clearing).

20. Event

An Event is a transmission incident that results in the Automatic Outage (Sustained or Momentary) of one or more Elements.

21. Event Identification (ID) Code

A unique alphanumeric identifier assigned by the Transmission Owner to an Event. Because outages that begin in one reporting year and end in the next reporting year must have the same Event ID Code, the code must have the reporting year appended to it to ensure its uniqueness. For example, an Event ID Code may be W324-2008. This unique Event ID Code establishes an easy way to identify which Automatic Outages are related to one another as defined by their Outage Mode Codes (see Section D).

1. An Event associated with a Single Mode Outage will have just one Event ID Code.
2. Each outage in a related set of two or more outages (e.g., Dependent Mode, Dependent Mode Initiating, Common Mode, or Common Mode Initiating) shall be given the same Event ID Code.

22. Event Type Number

A code that describes the type of Automatic Outage(s) that occurred.

Two tables are provided for Event Type Numbers that fall into two distinct categories.

Normal Clearing: This table applies under two conditions

1. When a fault has occurred *and* the Element is isolated under Normal Clearing.
2. When a fault has *not* occurred, *but* the Element is isolated by the *proper* operation of the Protection System. For example, a circuit breaker may be opened due to the detection of circuit breaker low gas pressure, causing the Protection System to operate. Or a Transformer may be isolated by the Protection System due to high oil temperature. Both of these events are categorized as Normal Clearing.

Abnormal Clearing: *This table applies under two conditions*

1. *When* a fault has occurred *and* the Element is isolated under Abnormal Clearing.
2. When a fault has *not* occurred, but the Element is isolated by the *failure or unintended* operation of the Protection System.

For example a low gas pressure sensor which is part of the Protection System may provide an incorrect sensor reading and cause the Protection System to operate when it would not otherwise have operated, but since the sensor and its controls are part of the Protection System its operation is abnormal (not-proper). The isolation of the Element was due to the Protection System's improper operation of a protection sensor. Since an

Automatic Outage was due to Abnormal Clearing, the event is categorized as Abnormal Clearing.

Another example of Abnormal Clearing is where an improper relay setting (either during design or by misapplication) causes an unintended outage of one or more Elements.

Event Type Number Descriptions

Events with <u>Normal Clearing</u>¹	
Event Type No.	Description
05	Single bus section fault or failure (200kV or above) resulting in one or more Automatic Outages.
06	Single internal circuit breaker fault (200kV or above) resulting in one or more Automatic Outages ² .
11	Automatic Outage of a single Element.
13	Automatic Outage of two or more Elements within one NCCBS.
31	Automatic Outages of two or more TADS adjacent AC Circuits or DC Circuits on common structures. To qualify as Event Type 31 the Automatic Outages must be the direct result of the circuits occupying common structures ³ .
49	Automatic Outage(s) with Normal Clearing not covered by Event Types 05 through 31 above ⁴ .

Events with <u>Abnormal Clearing</u>⁵	
Event Type No.	Description
60	Breaker Failure: One or more Automatic Outages with Delayed Fault Clearing due to a circuit breaker (200kV and above) being stuck, slow to open or failure to interrupt current.
61	Dependability (failure to operate): One or more Automatic Outages with Delayed Fault Clearing due to failure of a single Protection System (primary or secondary backup) under either of these conditions: <ul style="list-style-type: none"> a. failure to initiate the isolation of a faulted power system Element as designed, or within its designed operating time, or b. In the absence of a fault, failure to operate as intended within its designed operating time. (Item b is a very rare type of event.)
62	Security (unintended operation): One or more Automatic Outages caused by improper operation (e.g. overtrip) of a Protection System resulting in isolating one or more TADS Elements it is not intended to isolate, either during a fault or in the absence of a fault.
90	Automatic Outage(s) with Abnormal Clearing not covered by Event Types 60 through 62 above ⁶ .

Notes:

- 1) Event Type Numbers 05 to 49 are Events with Normal Clearing. These Event Type Numbers apply only when the Automatic Outages are the result of Protection Systems and controls disconnecting the elements that are expected to be automatically disconnected for a single event. Normal Clearing is defined in the NERC *Glossary of Terms Used in Reliability Standards*: “A protection system operates as designed and the fault is cleared in the time normally expected with proper functioning of the installed protection systems.”
- 2) An internal breaker fault means a breaker failing internally, thus creating a system fault which must be cleared by protection on both sides of the breaker.
- 3) As stated in the TADS definition of Multi-Circuit Structure Mile “. . . If a line section contains two or more Multi-Circuit Structures which form one or more multi-circuit spans, the total span length can be measured and the associated mileage should be reported in the ‘Multi-Circuit Structure Mile’ total inventory. If multiple circuits are connected to only one common structure, that structure should be ignored for outage and inventory mileage purposes.”
- 4) Event Type Number 49 also includes Automatic Outage(s) initiated by normal operation of a Special Protection System (SPS) or Remedial Action Scheme (RAS). SPS (a.k.a. RAS) are defined in the NERC Glossary of Terms. For convenience, this SPS definition has also been added to TADS Appendix 7 Definitions, Section B item 19.
- 5) Event Type numbers 60 to 90 are Events with Abnormal Clearing. These Event Type numbers apply when Normal Clearing (see Note 1) does not occur for any one or more Automatic Outage associated with the Event.
- 6) Event Type 90 also includes Automatic Outage(s) initiated by abnormal operation of a Special Protection System (SPS) or Remedial Action Scheme (RAS).

Event Type No. 11 and 13 Examples

1. For example, suppose a 500 kV AC Circuit is outaged and results in a tapped 500/230 kV Transformer outage due to Normal Clearing. This is an example of Event Type #13.
2. If the Transformer in the previous example had been a 500/138 kV Transformer, the Transformer would not be an Element and, therefore, only the AC Circuit outage would be reported in TADS. This is an example of Event Type #11.

Event Type No. 31 Examples

To qualify for an Event Type No. 31, the outages must be a direct result of the circuits occupying common structures. These characteristics will generally apply.

1. The Outage Initiation Codes are either Element-Initiated or Other-Element Initiated.
2. The Outage Mode Codes are one of the following: (a) Dependent Mode Initiating (first outage) and Dependent Mode (second outage); (b) Common Mode Initiating and Common Mode (two outages); or (c) both Common Mode (two outages).

These are examples of Events that are Event Type No. 31:

1. A tornado outages two 230kV AC Circuits on common structures. In this example, the outages are Element-Initiated and Common Mode. This is an Event Type No. 31 because the loss of both circuits was directly related to them being on the same structures.
2. On one 230kV AC Circuit, a conductor breaks (outaging the circuit), and the conductor swings into a second 230kV AC Circuit on common structures. The first circuit outage is Element-Initiated and Dependent Mode Initiating; the second circuit outage is Other-Element Initiated and Dependent Mode. This is an Event Type No. 31 because the second circuit's outage was a result of it being on common structures with the first circuit.

These Events are not an Event Type No. 31;

1. Two 230kV AC Circuits on common structures are outaged due to a bus fault in the AC Substation where the circuits terminate. Both outages are AC Substation-Initiated and Common Mode. Because the outages are not a result of the two circuits being on common structures, it is not an Event Type No. 31. It is an Event Type No. 05.
2. Two 230kV AC Circuits are on common structures and terminate at the same bus. Lightning strikes one of the 230kV circuits, but the breaker fails to open due to a failure of a relay to operate properly. The second circuit, which is connected to the same bus, is outaged as a result of the failure of first circuit's breaker to open. The first outage is an Element-Initiated and Dependent Mode Initiating; the second outage is Other Facility-Initiated and Dependent Mode. (Note: the relay is excluded as part of an AC Substation, making the Outage Initiation Code "Other-Facility Initiated" and not "AC Substation-Initiated.") Because the outages are not a result of the two circuits being on common structures, it is not an Event Type No. 31. It is an Event Type No. 60.

23. Fault Type

The descriptor of the fault, if any, associated with each Automatic Outage of an Element. Several choices are possible for each Element outage:

1. No fault
2. Phase-to-phase fault (P-P)
3. Single phase-to-ground fault (P-G)
4. Phase-to-phase-to-ground (P-P-G), 3P, or 3P-G fault
5. Unknown fault type

The term "associated with" could be broadly interpreted to mean any fault, no matter how remote, which results in an Automatic Outage of an Element. This is not intended. Therefore, the following guide is to be used for reporting Fault Type. This guide uses the Outage Initiation Codes described in Section C below.

If an Element has an Automatic Outage and its Outage Initiation Code is;

- a. “Element-Initiated,” report the Fault Type from one of the five above.
- b. “Other Element-Initiated,” report “No fault” as the Fault Type for the outage since a Fault Type will be reported for the other Element that initiated the outage.
- c. Either “AC Substation-Initiated” or “AC/DC Terminal Initiated,” report Fault Types from 2-5 above ONLY if a fault occurred on AC equipment that is 200 kV or greater; otherwise, report “No fault” if a fault did not occur OR if a fault occurred, but it occurred on AC equipment that is less than 200 kV.
- d. “Other Facility-Initiated,” report “No fault” as the Fault Type.

The Fault Type for each Element outage may be determined from recorded relay targets or by other analysis. TOs should use the best available data to determine (1) whether a fault was associated with the outaged Element and, if so, (2) what type of fault occurred.

Relay targets are not a fool proof method to determine the Fault Type; however, they may be the best available data to determine Fault Type. Relay targets should be documented as soon as practical after a fault and the targets re-set to prepare for the next fault. If a single fault results in several Element outages, the protective relay targets associated with each Element indicate the Fault Type for that Outage. Fault Types should be reported consistent with the guidance provided above. When a Fault Type is required and the Fault Type is not known by other analysis, the relay targets associated with each Element should be entered as the Fault Type for that Outage. When relays did not indicate a fault for an Element, the Event Type should be reported as “No fault” if tripping was not associated with clearing a fault, or “Unknown fault type” if tripping was associated with clearing a fault.

Example #1: A 500 kV AC Circuit experiences a single phase-to-ground fault on the Element, outaging the Element. The AC Circuit outage also results in an outage of a 500/230 kV Transformer that is connected to the 500 kV circuit. The Transformer did not experience a fault. The AC Circuit’s Outage Initiation Code would be “Element-Initiated” and its Fault Type would be “Single P-G fault.” The Transformer’s Outage Initiation Code would be “Other Element-Initiated” and its Fault Type would be “No fault.” See guides “a.” and “b.” above.

Example #2: A 500 kV AC Circuit trips when its relays operate due to a Protection System misoperation for a single phase-to ground fault on a 230/69 kV Transformer. The AC Circuit’s “Outage Initiation Code” should be entered as “Other Facility-Initiated Outage” (because it initiated on the Protection System, which misoperated) and the AC Circuit outage Fault Type should be reported as “No fault.” It does not matter if the fault was on the 230 kV or 69 kV side of the Transformer for this example. See guide “d.” above. Note that the Transformer outage will not be reported since it is not a TADS Element.

Example #3: A single phase-to ground 230 kV bus fault results in the outages of two 230 kV AC Circuits that are connected to that bus. Each circuit’s Outage Initiation Code should be entered as “AC Substation-Initiated.” Because the bus is 200 kV or greater and

the outage was “AC Substation Initiated,” the AC Circuit’s Fault Type would be entered as “Single P-G fault.” See guide “c.” above.

C. Outage Initiation Codes

The Outage Initiation Codes describe *where* an Automatic Outage was initiated on the power system.

1. Element-Initiated Outage

An Automatic Outage of an Element that is initiated on or within the Element that is outaged.

2. Other Element-Initiated Outage

An Automatic Outage of an Element that is initiated by another Element and not by the Element that is outaged.

3. AC Substation-Initiated Outage

An Automatic Outage of an Element that is initiated on or within AC Substation facilities. (Note: By the definition of “AC Substation” in Section A, the Protection System is excluded; it is therefore included in “Other Facility-Initiated Outage.”)

4. AC/DC Terminal-Initiated Outage

An Automatic Outage of an Element that is initiated on or within AC/DC Terminal facilities. (Note: By the definition of “AC/DC Terminal” in Section A, the Protection System is excluded; it is therefore included in “Other Facility-Initiated Outage.”)

5. Other Facility-Initiated Outage

An Automatic Outage that is initiated on or within other facilities. “Other facilities” include any facilities not includable in any other Outage Initiation Code. (Note: An Automatic Outage initiated on a Transformer that is *not* an Element is considered an AC Substation or an AC/DC Terminal-Initiated Outage since the Transformer would be considered part of an AC Substation or AC/DC Terminal.)

Outage Initiation Code Examples

1. A Transformer which is an Element is outaged. Is its outage an Element-Initiated Outage or an AC Substation-Initiated Outage? It depends. If the outage initiated on or within the Element (e.g., an internal fault or a cracked insulator that caused a fault), the outage is Element-Initiated, even though the Transformer is in a Substation. However, if the Transformer outage was not due to the Transformer itself but due, for example, to a failed circuit breaker, it is AC Substation-Initiated.
2. An AC Circuit which is an Element has an outage that was initiated by a non-Element AC Circuit. The Element outage is Other Facility-Initiated.
3. An AC Circuit Outage was initiated by an Element Transformer outage. The AC Circuit Outage is Other Element-Initiated.

D. Outage Mode Codes

The Outage Mode Code describes whether an Automatic Outage is related to other Automatic Outages.

1. Single Mode Outage

An Automatic Outage of a single Element which occurred independent of any other Automatic Outages (if any).

2. Dependent Mode Initiating Outage

An Automatic Outage of a single Element that initiates one or more subsequent Element Automatic Outages.

3. Dependent Mode Outage

An Automatic Outage of an Element which occurred as a result of an initiating outage, whether the initiating outage was an Element outage or a non-Element outage. (Note: to re-emphasize, a Dependent Mode Outage must be a result of another outage.)

4. Common Mode Outage

One of two or more Automatic Outages with the same Initiating Cause Code and where the outages are not consequences of each other and occur nearly simultaneously (i.e., within cycles or seconds of one another).

5. Common Mode Initiating Outage

A Common Mode Outage that initiates one or more subsequent Automatic Outages.

Dependent Mode and Common Mode Outage Examples

1. A Dependent Mode Outage involves two outages, but one of the outages can be a non-Element outage. Therefore, not all Dependent Mode Outages will have an associated Dependent Mode Initiating Outage. If the initiating outage is one of the four defined Elements, that outage will be a Dependent Mode Initiating Outage, and the resulting second Element outage will be a Dependent Mode Outage. For example, suppose a 500 kV AC Circuit is outaged as a result of a 500/230 kV Transformer outage. The AC Circuit outage is a Dependent Mode Outage, and the Transformer outage is a Dependent Mode Initiating Outage. However, if an outage is not initiated by an Element, it will not have an associated Dependent Mode Initiating Outage. If the Transformer in the previous example had been a 345/138 kV Transformer and the AC Circuit a 345 kV circuit, the Transformer would not be an Element and, therefore, the AC Circuit outage would not have an associated Dependent Mode Initiating Outage. The AC Circuit outage would be classified as a Dependent Mode Outage since it was the result of a non-Element outage.
2. A Common Mode Outage involves the two outages, but unlike a Dependent Mode Outage, both outages must be Elements. In addition, one outage must not cause the second outage to occur; i.e., the two outages are not consequences of each other. In addition, they must occur nearly simultaneously. As an example, suppose that lightning strikes two AC Circuits in the same right of way (but not

on a common structure) and both circuits are outaged nearly simultaneously. Assume no further outages occur. Both are Common Mode Outages. Now assume the same scenario with a slight difference: one AC Circuit clears normally, the second AC Circuit does not, and there is a circuit breaker failure, resulting in the outage of a third AC Circuit. The first AC Circuit outage is a Common Mode Outage. The second AC Circuit outage is a Common Mode Initiating Outage, with the third AC Circuit outage a Dependent Mode Outage.

E. Automatic Outage Cause Code Types

1. Initiating Cause Code

The Automatic Outage Cause Code that describes the initiating cause of the outage.

2. Sustained Cause Code

The Automatic Outage Cause Code that describes the cause that contributed to the longest duration of the outage. Momentary Outages do not have a Sustained Cause Code.

Initiating and Sustained Cause Code Examples

Example #1: Suppose a lightning strike on an AC Circuit that should have cleared normally becomes a Sustained Outage because of breaker failure. “Lightning” is the Initiating Cause Code and “Failed AC Substation Equipment” is the Sustained Cause Code.

Example #2: Wind causes galloping on a conductor resulting in a circuit lock-out. Several hours pass before the circuit can be patrolled to determine whether there was any damage. After patrolling, no damage was found and the circuit was successfully re-energized. “Weather, excluding lightning” is the Initiating Cause Code as well as the Sustained Cause Code.

How to interpret “contributed to the longest duration”

To illustrate the meaning of the phrase “contributed to the longest duration” in the definition above, suppose that lightning caused a conductor to break (“Failed AC Circuit Equipment”) and that the breaker for the circuit also failed (“Failed AC Substation Equipment”). This example has two possible Sustained Cause Codes, and the one to select is the one that contributed to the longest duration. If the conductor was repaired before the circuit breaker, then “Failed AC Substation Equipment” is the Sustained Cause Code since the circuit breaker outage contributed to the longest duration.

F. Automatic Outage Cause Codes

1. Weather, excluding lightning

Automatic Outages caused by weather such as snow, extreme temperature, rain, hail, fog, sleet/ice, wind (including galloping conductor), tornado, microburst, dust storm, and flying debris caused by wind.

2. Lightning

Automatic Outages caused by lightning.

3. Environmental

Automatic Outages caused by environmental conditions such as earth movement (including earthquake, subsidence, earth slide), flood, geomagnetic storm, or avalanche.

4. Contamination

Automatic Outages caused by contamination such as bird droppings, dust, corrosion, salt spray, industrial pollution, smog, or ash.

5. Foreign Interference

Automatic Outages caused by foreign interference from such objects such as an aircraft, machinery, a vehicle, a train, a boat, a balloon, a kite, a bird (including streamers), an animal, flying debris not caused by wind, and falling conductors from one line into another. Foreign Interference is not due to an error by a utility employee or contractor. Categorize these as “Human Error.”

6. Fire

Automatic Outages caused by fire or smoke.

7. Vandalism, Terrorism or Malicious Acts

Automatic Outages caused by intentional activity such as shot conductors or insulators, removing bolts from structures, and bombs.

8. Failed AC Substation Equipment

Automatic Outages caused by the failure of AC Substation; i.e., equipment “inside the substation fence” including Transformers and circuit breakers but excluding Protection System equipment. Refer to the definition of “AC Substation.”

9. Failed AC/DC Terminal Equipment

Automatic Outages caused by the failure of AC/DC Terminal equipment; i.e., equipment “inside the terminal fence” including PLC (power-line carrier) filters, AC filters, reactors and capacitors, Transformers, DC valves, smoothing reactors, and DC filters but excluding Protection System equipment. Refer to the definition of “AC/DC Terminal.”

10. Failed Protection System Equipment

Automatic Outages caused by the failure of Protection System equipment. Includes any relay and/or control misoperations *except* those that are caused by incorrect relay or control settings that do not coordinate with other protective devices. Categorize these as “Human Error”.

11. Failed AC Circuit Equipment

Automatic Outages related to the failure of AC Circuit equipment, i.e., overhead or underground equipment “outside the substation fence.” Refer to the definition of “AC Circuit.”

12. Failed DC Circuit Equipment

Automatic Outages related to the failure DC Circuit equipment, i.e., overhead or underground equipment “outside the terminal fence.” Refer to the definition of “DC Circuit.” However, include the failure of a connecting DC bus within an AC/DC Back-to-Back Converter in this category.

13. Vegetation

Automatic Outages (both Momentary and Sustained) caused by vegetation, with the exception of the following exclusions which are contained in FAC-003-1:

1. Vegetation-related outages that result from vegetation falling into lines from outside the right of way that result from natural disasters shall not be considered reportable with the Vegetation Cause Code. Examples of disasters that could create non-reportable Vegetation Cause Code outages include, but are not limited to, earthquakes, fires, tornados, hurricanes, landslides, wind shear, major storms as defined either by the Transmission Owner or an applicable regulatory body, ice storms, and floods, and
2. Vegetation-related outages due to human or animal activity shall not be considered reportable under the Vegetation Cause Code. Examples of human or animal activity that could cause a non-reportable Vegetation Cause Code outage include, but are not limited to, logging, animal severing tree, vehicle contact with tree, arboricultural activities or horticultural or agricultural activities, or removal or digging of vegetation.

Outages that fall under the exclusions should be reported under another Cause Code and not the Vegetation Cause Code.

14. Power System Condition

Automatic Outages caused by power system conditions such as instability, overload trip, out-of-step, abnormal voltage, abnormal frequency, or unique system configurations (e.g., an abnormal terminal configuration due to existing condition with one breaker already out of service).

15. Human Error

Automatic Outages caused by any incorrect action traceable to employees and/or contractors for companies operating, maintaining, and/or providing assistance to the Transmission Owner will be identified and reported in this category. Also, any human failure or interpretation of standard industry practices and guidelines that cause an outage will be reported in this category.

16. Unknown

Automatic Outages caused by unknown causes should be reported in this category.

17. Other

Automatic Outages for which the cause is known; however, the cause is not included in the above list.

G. Planned Outage Cause Codes

1. Maintenance and Construction

Use for Planned Outages associated with maintenance and construction of electric facilities, including testing. This includes requests from any entity that is defined in the NERC Functional Model.⁶

2. Third-Party Requests

Use for Planned Outages that are taken at the request of a third party such as highway departments, the Coast Guard, etc.

3. Other Planned Outage

Use for Planned Outages for reasons not included in the above list, including human error.

H. Operational Outage Cause Codes

1. Emergency

Use for Operational Outages that are taken for the purpose of avoiding risk to human life, damage to equipment, damage to property, or similar threatening consequences.

2. System Voltage Limit Mitigation

Use for Operational Outages taken to maintain the voltage on the transmission system within desired levels (i.e., voltage control).

3. System Operating Limit Mitigation, excluding System Voltage Limit Mitigation

Use for Operational Outages taken to keep the transmission system within System Operating Limits, except for System Voltage Limit Mitigation. The term “System Operating Limit” is defined in the NERC *Glossary of Terms Used in Reliability Standards* and is excerpted in the text box on the next page.

⁶ The Functional Model is available at http://www.nerc.com/files/Functional_Model_V4_CLEAN_2008Dec01.pdf. As an example, an outage is requested by a Generation Operator for purposes of completing an interconnection of its facilities would be classified in the Maintenance and Construction category. A Load-Serving Entity which requests an outage to make repairs to its substation would also be reported in this category.

System Operating Limit:

The value (such as MW, MVar, Amperes, Frequency or Volts) that satisfies the most limiting of the prescribed operating criteria for a specified system configuration to ensure operation within acceptable reliability criteria. System Operating Limits are based upon certain operating criteria. These include, but are not limited to:

1. Facility Ratings (Applicable pre- and post-Contingency equipment or facility ratings)
2. Transient Stability Ratings (Applicable pre- and post-Contingency Stability Limits)
3. Voltage Stability Ratings (Applicable pre- and post-Contingency Voltage Stability)
4. System Voltage Limits (Applicable pre- and post-Contingency Voltage Limits).

Do not include actions in the last category (System Voltage Limits) since this is included in the previous “System Voltage Limitation” code.

4. Other Operational Outage

Use for Operational Outages for reasons not included in the above list, including human error.