

Appendix K – Outside Management Control

Following this introduction of Outside Management Control (OMC) guidelines, we have listed those cause codes that GADS recognizes as being outside plant management control. At the end of this Appendix are guidelines for removing OMC events from standard calculations.

Annex D: Outside of Plant Management Control

The electric industry in Europe and other parts of the world has made a change to examine losses of generation caused by problems with and outside plant management control. After reviewing the work used by others, the following is provided as guidelines for determining what is and is not outside plant management control:

There are a number of outage causes that may prevent the energy coming from a power generating plant from reaching the customer. Some causes are due to the plant operation and equipment while others are outside plant management control.

The standard sets a boundary on the generator side of the power station (see Figure D-1, below) for the determination of equipment "outside management control".

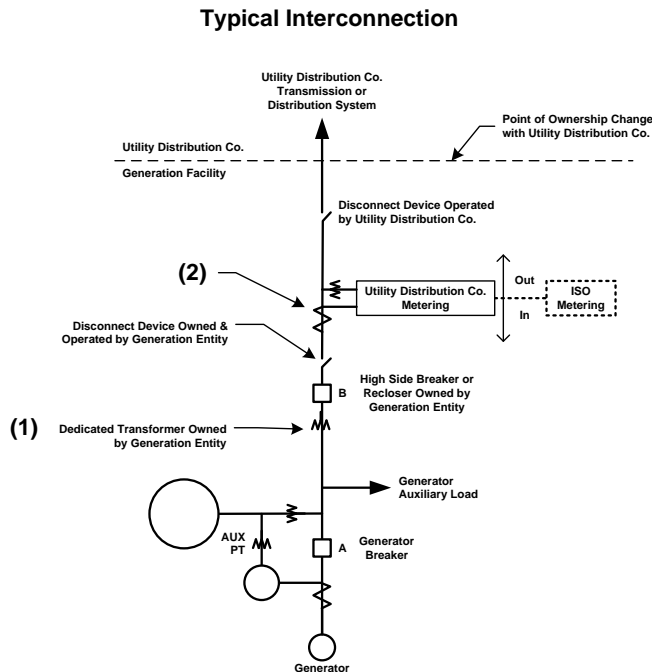

Figure D-1
The Physical Boundary of Outside Management Control

As shown in Figure D-1, a generating unit includes all equipment up to (in preferred order) (1) the high-voltage terminals of the generator step-up (GSU) transformer and the station service transformers; (2) the GSU transformer (load) side of the generator-voltage circuit breakers; or (3) at such equipment boundary as may be reasonable considering the design and configuration of the generating unit.

It may be assumed that all problems within the power station boundary are within plant management control; however that is not always the case. Therefore, there is a need for some additional clarification as to what is and what is not under plant management control.

It is easier to identify those actions outside plant management control than to identify the responsibilities of plant management. Therefore, the following are considered to be outside (external) of plant management control. All other items are considered within their jurisdiction and are the responsibility of the plant management for calculating power plant performance and statistics.

Energy losses due to the following causes should not be considered when computing the unit controllable performance because these losses are not considered to be under the control of plant management:

- Grid connection or substation failure. This reason relates to problems with transmission lines and switchyard equipment outside the boundaries of the plant as specified by the “boundary of plant responsibility” shown in Figure D-1 on this Annex.
- Acts of nature such as ice storms, tornados, winds, lightning, etc are not under plant management control, whether inside or outside the plant boundary.
- Terrorist attacks on the generating/transmission facilities or transmission operating/repair errors are not under plant management control.
- Special environmental limitations such as low cooling pond level, or water intake restrictions that could not be prevented by operator action. These are acts of nature such as high ambient temperatures where the equipment is working within design specifications. However, if the equipment is not maintained by the plant such as opacity out of limits or NOx out of control, etc, then plant management should be penalized. These are equipment problems and are within plant management control.
- Lack of fuels (water from rivers or lakes, coal mines, gas lines, etc) where the operator is not in control of contracts, supply lines, or delivery of fuels.

However, if the operator elected to contract for fuels where the fuel (for example, natural gas) can be interrupted so that the fuel suppliers can sell the fuels to others (part of the plant fuel cost-saving measure), then the lack of fuel is under management control and is not applicable to this case.

- Labor strikes. Outages or load reductions caused by labor strikes are not normally under the direct control of plant management. These strikes may be company-wide problems or strikes outside the company's jurisdiction such as manufacturers (delaying repairs) or transportation (fuel supply) problems.

However, direct plant management grievances that result in a walkout or strike are under plant management control and are included as penalties against the plant. If a labor strike is caused by plant management/worker problems during an outage, any outage extensions are included as energy losses as long as the unit is incapable of being restarted because of equipment failures, maintenance, overhauls, or other activities.

- Other weather related problems such as seasonal variations in gross dependable capacity due to cooling water temperature variations are not within plant management control.

This completes the quote from Annex D of IEEE 762. For more comments on OMC events, please refer to Section I-2 and III-13 of these *GADS Data Reporting Instructions*.

GADS Cause Codes Outside Plant Management Control

(as of January 1, 2006)

- 3600 Switchyard transformers and associated cooling systems - external
- 3611 Switchyard circuit breakers - external
- 3612 Switchyard system protection devices - external
- 3619 Other switchyard equipment - external
- 3710 Transmission line (connected to powerhouse switchyard to 1st Substation)
- 3720 Transmission equipment at the 1st substation) (see code 9300 if applicable)
- 3730 Transmission equipment beyond the 1st substation (see code 9300 if applicable)
- 9000 Flood
- 9010 Fire, not related to a specific component
- 9020 Lightning
- 9025 Geomagnetic disturbance
- 9030 Earthquake
- 9035 Hurricane
- 9036 Storms (ice, snow, etc)
- 9040 Other catastrophe
- 9130 Lack of fuel (water from rivers or lakes, coal mines, gas lines, etc) where the operator is not in control of contracts, supply lines, or delivery of fuels
- 9135 Lack of water (hydro)
- 9150 Labor strikes company-wide problems or strikes outside the company's jurisdiction such as manufacturers (delaying repairs) or transportation (fuel supply) problems.
- 9200 High ash content
- 9210 Low grindability
- 9220 High sulfur content
- 9230 High vanadium content
- 9240 High sodium content
- 9250 Low Btu coal
- 9260 Low Btu oil
- 9270 Wet coal
- 9280 Frozen coal
- 9290 Other fuel quality problems
- 9300 Transmission system problems other than catastrophes (do not include switchyard problems in this category; see codes 3600 to 3629, 3720 to 3730)
- 9320 Other miscellaneous external problems
- 9500 Regulatory (nuclear) proceedings and hearings - regulatory agency initiated
- 9502 Regulatory (nuclear) proceedings and hearings - intervener initiated
- 9504 Regulatory (environmental) proceedings and hearings - regulatory agency initiated
- 9506 Regulatory (environmental) proceedings and hearings - intervenor initiated
- 9510 Plant modifications strictly for compliance with new or changed regulatory requirements (scrubbers, cooling towers, etc.)
- 9520 Oil spill in Gulf of Mexico
- 9590 Miscellaneous regulatory (this code is primarily intended for use with event contribution code 2 to indicate that a regulatory-related factor contributed to the primary cause of the event)

**Policy on Handling Outside Management Control (OMC)
Events and their Equations in GADS**
(as of December 9, 2004)

Background

The IEEE 762 “Definitions for Reporting Electric Generating Unit Reliability, Availability and Productivity” (Annex D) is the basis for the OMC work. In part, Annex D states that:

“There are a number of outage causes that may prevent the energy coming from a power generating plant from reaching the customer. Some causes are due to the plant operation and equipment while others are outside plant management control.”

This Appendix K lists a number of cause codes that is universally accepted as those outside the control of management by the GADS program. It also identifies certain conditions under which those specific cause codes would be applied. The list may change with time and some additional clarifications may be added.

The list of cause codes shown hereafter should be reviewed from time to time to insure the latest cause codes are used in the OMC equations.

It is also VERY important that all cause codes (including all OMC cause codes) be reported to GADS. Some companies may wish to exclude a forced outage or change it to a non-curtailing event if it fits into the OMC category. THAT IS NOT RIGHT! The event should be reported as a forced outage and the OMC calculations will show the events without the FO.

Handling OMC Events

OMC events will come in two forms: outages or deratings. The OMC event types can be either forced, maintenance or planned but it is expected that the majority will be forced outage events.

For all existing GADS equation calculations, the OMC events will be treated as a standard event, i.e., a forced outage, forced derate, etc. The calculation will not change and will follow the calculations shown in Appendix F of the GADS DRI.

In calculating equations without OMC events, it is important to remember that the objective of the removal of OMC events is to affect the availability of the unit. To that end, we handle outages differently than derates. In removing a particular event from a unit’s event records we are faced with the question of what to put in place of the missing event. In the case of an outage, there is no sure way of knowing in what state a unit should be considered. The only sure thing is our objective of returning those hours to an available state. That is exactly what we do and that is all we do. Assuming that the unit is in reserve or in service during the time of the removed OMC outage event, and so, adding to either service or reserve hours presents a fictional summary of the unit’s performance. In viewing the available hours we temporarily recalculate AH as (Service + Reserve + Synchronous-Condensing. + Pumping + OMC).

In the case of a derating event, however, we know for certain the state of the unit at the time of the removed event. Knowing this forces us to place at least part of the equivalent available hours gained in to either reserve or service. Whenever an event is removed it is necessary to look for any derating events that may have been shadowed by or overlapping the removed event. Those overlapping hours must be accounted for by the software processing the OMC event. It isn't enough to simply recalculate Equivalent Availability by adding the sum of the removed OMC events because we need to now take into account the effect of the newly uncovered (un-overlapped) derating events.

Before we begin defining the methods there is an important assumption that needs to be made as to the processing of the data. – Since the removal of the OMC outage event is seen as an adjustment, we'll assume that outage events have been processed as normal and that OMC removal is acting on clean data and that performance totals have already been summed for the unit. Also, in the case of derate events, that loss attributed to an event has been calculated particularly in the case of overlapping and shadowed events.

OMC Process Methods by Event Type

1. **Outage Events** – In simple terms, when an OMC outage event is encountered, the total associated hours would be reduced as well as the number of occurrences. In order to help keep our numbers in balance, we'll add these hours to an OMC Hours category. Notice that in each example below we are increasing available hours and not service hours even though we are reducing outage hours.
 - a. **Forced Outage** – Regardless of whether it is a U1, U2, U3 or SF, removing an OMC_FO event would cause a decrease in Forced Outage hours and Forced Outage Occurrences and an increase in Available Hours.
 - b. **Planned Outage** – Removing an OMC_PO event would cause a decrease in Planned Outage hours and Planned Outage Occurrences and an increase in Available Hours.
 - c. **Maintenance Outage** – Removing an OMC_MO event would cause a decrease in Maintenance Outage hours and Maintenance Outage Occurrences and an increase in Available Hours.
 - d. **Derate Event shadowed by an OMC outage** – If the removed OMC outage event shadows a derating event, the equivalent hours shadowed by the outage needs to be added into the equivalent outage hours so that it can be reflected in the equivalent availability.

2. **Derate Events** – In removing OMC derate events, it is important to keep in mind that the loss of capacity originally calculated and attributed to an event is maintained when the OMC event is removed. The removal of the OMC event then properly affects the available capacity of the unit rather than increasing the losses attributed to the surrounding / overlapping derating events. Illustrations are included below in order to aid the explanations.
- a. **A simple OMC derate** – When there are no overlapping derating events, the equivalent hours of the OMC event can be removed from the total equivalent hours and the associated event occurrences can also be reduced by 1. The number of derate hours also is reduced by the duration of the event.
 - b. **An OMC derate event overlapped by another derate** – If an OMC event is removed and there is another overlapping derate event, the OMC is removed and totals are adjusted just as in case ‘a’ above. The NAC of the unit at the start of the overlapping event is increased, but the loss attributed to that event remains constant. (Normal derate events are considered loss-constant throughout their duration)
 - c. **OMC derate event which is shadowed by a dominant derate** – In this case, the overlapping derate is dominant and so, is considered to be capacity-constant. This means that removing the OMC event has no affect on the available capacity within the dominant overlapping derate. The adjustment to the unit performance stats would be limited to the duration and equivalent hours of that portion of the OMC event that exists outside the dominant derate.
 - d. **A dominant OMC derate overlaps another derate** – When the OMC derate event is marked as dominant, multiple adjustments may be necessary. The first adjustment is to take care of the total duration and equivalent hours of the OMC derate event. Once the OMC derate event affect is removed, the overlapped derate event(s) need to be accounted for by subtracting those portions of the event(s) that were overlapped by the OMC event from the equivalent hours total as well as the any total durations. The number of derate event occurrences would not need to be adjusted.
 - e. **OMC derate event is shadowed by an outage** – Since an outage effectively truncates the derate event, only the portion of the OMC derate that extends outside the overlapping outage needs to be accounted for and removed.

Appendix K – Outside Management Control

Example#	Before OMC event removal	After OMC event removal
<p>1-d - Derate Event shadowed by an OMC outage</p>		
	<p>OMC Outage (any type) is removed from shadowed derate.</p>	<p>Unit available hours increase by the outage duration. Equivalent hours are adjusted downward by the overlapped portion when derate d1 is now accounted for at its actual value.</p>
<p>2-b - An OMC derate event overlapped by another derate</p>		
	<p>OMC Derate is removed from under D2</p>	<p>Loss attributed to D2 remains unchanged. NAC of the unit increases</p>
<p>2-c - OMC derate event which is wholly or partially shadowed by a dominant derate</p>		
	<p>OMC Derate is removed from inside D2</p>	<p>Only the portion outside the dominant derate is adjusted back to available hours</p>
<p>2-d – Dominant OMC derate overlaps other derates</p>		
	<p>Dominant OMC Derate is removed.</p>	<p>Events D1, D2 and D4 are extended and totalled at their original values.</p>
<p>2-e - OMC derate event is shadowed by an outage</p>		
	<p>OMC Derate is removed from being shadowed by an outage (any type)</p>	<p>The effect of removing the OMC event is to increase availability by the portions which extend beyond the outage.</p>

New OMC Equations

In the October 2003 GADS DRI, there are two equations listed in Appendix F that exclude OMC event hours. These two equations, Weighted Unit Capability Factor (WUCF) and Weighted Unit Capability Loss Factor (WUCLF) are used in Europe and are a start (not the only ones but a start) of equations for excluding OMC events. WUCF is the equivalent to WEAFF without OMC events; WUCLF is the equivalent to Weighted Equivalent Unplanned Outage Factor without OMC events. Both are capacity-weighted calculations.

There will be a number of other equations that people will want without OMC events including FOR, EFOR, EFORD, AF, or any equation that uses forced outage or unplanned outage numbers in it. The same principal will apply to planned or maintenance OMC events, if any. This type of reaction to OMC is expected. But there must be a method for clarifying which calculations include and exclude OMC events.

Please note that all equations that include OMC events be calculated in the same methods and have the same names as that in IEEE 762 and Appendix F of the GADS DRI. In other words, those equations will not change at all but will be the benchmark as to what the unit was able to provide under all circumstances.

Please note also that any equation that excludes OMC events be calculated in the same methods as that in IEEE 762 and Appendix F of the GADS DRI but the names are modified to show they exclude OMC events. These equations will be used against the benchmark calculations to show what the unit *could* have done without OMC events. Both numbers will be provided by GADS and either number can be used based on the needs and the reports.

As a convention for identifying equations and calculations without OMC events, it is proposed that for any equation without OMC events, that the name be modified with a starting “X” for “exclude” as a lead. Thus, EFOR without OMC events would be XEFOR, EFORD without OMC events would be XEFORD, POF with OMC events would be XPOF, etc. The “X” is to show that the equation excludes OMC events and the remainder of the name shows how it is calculated. EFOR and XEFOR are both apples but one is a Macintosh and the other a Roman Beauty.

