

Understanding the Grid

August 2013

How It Works

Unlike water or gas, electricity cannot be stored in large quantities. It must be generated at the instant it is used, which requires supply be kept in constant balance with demand. Furthermore, electricity flows simultaneously over all transmission lines in the interconnected grid system in inverse proportion to their electrical resistance, so it generally cannot be routed over specific lines. This means generation and transmission operations in North America must be monitored and controlled in real time, 24 hours a day, to ensure a reliable and continuous supply of electricity to homes and businesses. This requires the cooperation and coordination of hundreds of electricity industry participants.

NERC is responsible for aspects of an international electricity system that serves 334 million people and has some 211,000 miles (340,000 km) of high-voltage transmission lines.

This diagram below depicts the basic elements of the electricity system: how it is created at power generating stations and transported across high-voltage transmission and lower-voltage distribution lines to reach homes and businesses. Transformers at generating stations step the electric voltage up for efficient transport and then step the voltage down at substations to efficiently deliver power to customers.

The generation and transmission components and their associated control systems comprise the “bulk power system.”

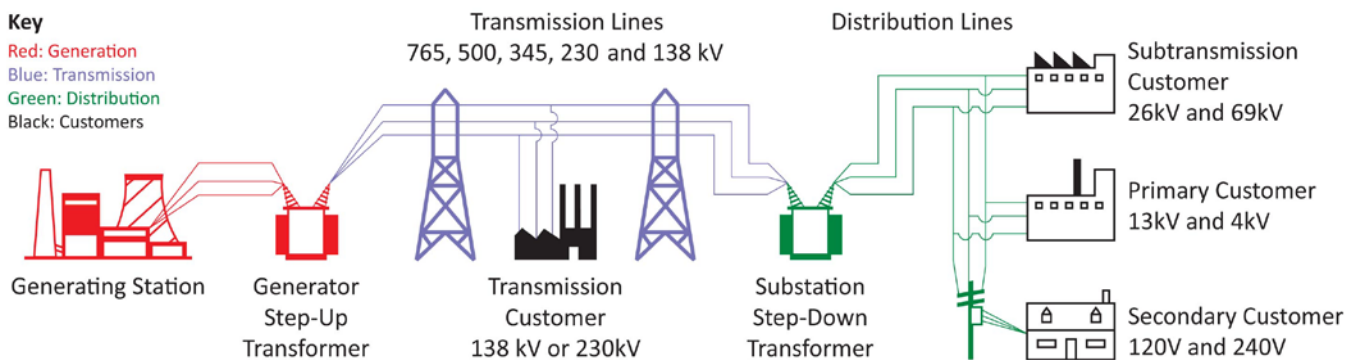

Reliability Concepts

NERC defines the reliability of the interconnected bulk power system in terms of two basic and functional aspects:

- **Adequacy.** The ability of the electricity system to supply the aggregate electrical demand and energy requirements of the end-use customers at all times, taking into account scheduled and reasonably expected unscheduled outages of system elements.
- **Operating Reliability.** The ability of the bulk power system to withstand sudden disturbances, such as electricity short circuits or unanticipated loss of system elements from credible contingencies, while avoiding uncontrolled cascading blackouts or damage to equipment.

Regarding adequacy, system operators can and should take “controlled” actions or procedures to maintain a continual balance between supply and demand within a Balancing Area (formerly called a control area). These actions include:

- Public appeals
- Interruptible demand: Customer demand that, in accordance with contractual arrangements, can be interrupted by direct control of the system operator or by action of the customer at the direct request of the system operator
- Voltage reductions: Referred to as “brownouts” because lights will dim as voltage is lowered
- Rotating blackouts. The term is used because each set of distribution feeders is interrupted for a limited time, typically 20–30 minutes, and then those feeders are put back in service and another set is interrupted, and so on, rotating the outages among individual feeders

All other system disturbances that result in the unplanned and/or uncontrolled interruption of customer demand, regardless of cause fall under the heading operating reliability. When these interruptions are contained within a localized area, they are considered unplanned interruptions or disturbances. When they spread over a wide area of the grid, they are referred to as “cascading blackouts” — the uncontrolled successive loss of system elements triggered by an incident at any location. Cascading results in widespread electric service interruption that cannot be restrained from sequentially spreading beyond an area predetermined by studies.

What occurred in 1965 and again in 2003 in the Northeast and in 2011 in the Southwest were uncontrolled cascading blackouts. What happened in the summer of 2000 in California, when supply was insufficient to meet all the demand, was a “rotating blackout” or controlled interruption of customer demand to maintain a balance with available supplies while maintaining the overall operating reliability of the interconnected system.