

Notes

Balancing Authority Controls SDT— Project 2007-05

April 29, 2010 | 8:00 am – 5:00 pm CDT

April 30, 2010 | 8:00 am – 12:00 CDT

Ameren Offices
1901 Chouteau Avenue
St. Louis, MO

1. Administration

a. Antitrust Guidelines

Andy Rodriguez reviewed the anti-trust guidelines with meeting participants.

b. Introduction of Attendees

The following members and guests were in attendance:

- Larry Akens, Chairman
- Gerry Beckerle
- Bill Campbell
- Dave Folk
- Will Franklin
- Howard Illian
- Ken McIntyre
- Sydney Niemeyer
- Guy Quintin
- Kris Ruud
- Wayne vanLiere
- Tom Washburn
- Leslie Williams
- Guy Zito
- Andy Rodriguez

The team questioned the status of Steve Gillespie. Andy reported that he had heard Steve was no longer with California ISO. Members of the team stated they would confirm this through their channels. If this is correct, then we will need to consider replacing him to ensure WECC

representation. The team also asked Andy to follow up with Mark Thomas to check on his participation.

c. Approval of Agenda

The drafting team reviewed the Agenda. The team approved the Agenda unanimously.

d. Approval of Meeting Notes

The drafting team approved the January and February meeting notes unanimously. Andy has not finished preparing the March meeting notes.

2. Discussion of Work Efforts

Larry expressed concern to the team that we were not making significant progress on our work products, and suggested that we replace our 6 yearly conference call meetings with in-person meetings. Andy briefly discussed FERC Order 693 and the recent issuances from March 18th, but deferred further discussion until item 4. The team briefly reviewed the roadmap.

3. Coordination Efforts

Andy and Larry provided a brief overview of what work had occurred during the earlier parts of the week (this meeting was the tail end of a series of meetings in St Louis related to Balancing, including the RS, the RBCSDT, a subset of the members of the Frequency Response Initiative, and the ADI task force (meeting concurrently with the BACSDT). Andy provided an overview of the terms being developed to describe frequency events; while the team had suggestions on the terms and their definition, Andy requested that the team send comments to Bob Cummings, and he is the current “owner” of the document.

Andy has no news to report regarding NAESB and the TIMTF.

4. Discussion of March 18 Orders

Andy offered a discussion of the March 18th orders and how they relate to the BACSDT. The team discussed the Time Error Correction NOPR and what NERC had included in its filing (a request for a technical conference about whether TECs should continue in the future). Andy then stated that although the majority of the March 18 Orders did not address items the BACSDT was working on, there was nonetheless a general concern that the directives in 693 were not being addressed in a timely fashion. Andy then reviewed where he believes the team is on each of the directives and what options there are.

5. Discussion of BAL-002 (DCS)

The team discussed the DCS standard. The idea of defining a floor was still difficult to accomplish. There was some thought that it should be the larger of the entities most severe single loss (of gen, load, or transfer) OR an analyzed value

based on size and/or probability, but it was uncertain what that analysis should entail. Everyone seemed to agree that MSSC was an absolute minimum.

Ken McIntyre expressed concern that as written, the standard was putting all the obligation on the BA, when the BA could only ask the generators to perform – not ensure that they do perform. The team agreed they would need to think about WHAT we want to happen, and then figure out HOW to make it happen and WHO to assign it to.

6. Discussion of BAL-004 (Time Error Correction)

Andy presented a version of BAL-004 that was a hybrid of the last version developed by the team and the previous version developed by the team (which included items that addressed much of what was contained in the FERC NOPR). From a strategy perspective, the team felt it made sense to “shelve” this standard until some indication of how the Final Rule will look is developed (i.e., if a Technical Conference is convened, it may turn out that we simply need a standard that says scheduled frequency is always 60Hz and there is no need for TECs or an associated reliability standard). David Folk volunteered to assist in developing the measures and compliance for the standard.

7. Discussion of BAL-013 and Operating Reserves

The team discussed Operating Reserves. Guy prepared a diagram to show how he thinks about Operating Reserves:

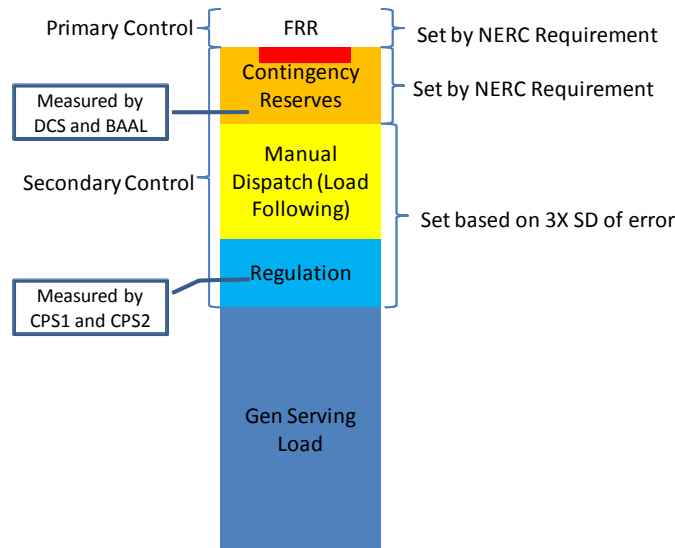

The team took some polls in an attempt to limit scope on its activities. Everyone agreed that frequency responsive reserve, regulating reserve, and contingency reserve needed to be measured after the fact. It was agreed that frequency responsive reserve needed some kind of measure ahead of time to ensure that enough was available before an event occurred (although it was also generally agreed that this was not the job of the BACSDT, but the FRRSDT). Similarly, it was agreed that contingency reserve needed to be measured ahead of time.

However, when it came to regulating reserve, the team generally agreed that it should be addressed only by the performance-based after the fact measure. This seemed to be because FRR and CR performance would be observed during comparatively rare events, while performance of regulation would be an ongoing observance.

The team still felt it was appropriate to have a Operating Reserves standard developed by the BACS DT that established some of the details about reserves.

For FRR, it was generally agreed that the BA should be required to allocate their FRR among its resources to ensure there is room available to move both directions. The Gen (Resource?) Owner must ensure that resources it offers to provide FRR meet certain characteristics, and provide information regarding its resource's characteristics to the BA.

Similarly, for CR, the BA should be assigned some minimal level of reserves it must provide. The Gen (Resource?) Owner must ensure that resources it offers to provide CR meet certain characteristics, and provide information regarding its resource's characteristics to the BA.

As discussed in BAL-002, there will be a need to make sure that the appropriate entities are assigned responsibility. Making the BA responsible for things controlled by the GO will not result in a good standard.

8. Discussion of FAC/Metering Standard

The team did not have time to discuss this item.

9. Assignments and Action Items

Andy to raise the question of registration regarding DSM, flywheels, batteries, etc... with NERC staff.

10. Future Meetings (*Italics not confirmed*)

May 19– ConCall/WebEx, 10-4 Central

June 22,23 – Meeting, Chicago, IL (full day full day)

July 12,13 – Meeting, St. Paul (half day, full day)

August 3,4 – Meeting, Princeton or Montreal (full day, full day)

11. Adjourn

The drafting team adjourned at approximately 12:00 noon.