

Standard Development Timeline

This section is maintained by the drafting team during the development of the standard and will be removed when the standard is adopted by the NERC Board of Trustees (Board).

Description of Current Draft

This is the second draft of the proposed standard being posted for a formal 45-day comment period and additional ballot.

<u>Completed Actions</u>	<u>Date</u>
<u>Standards Committee approved Standard Authorization Request (SAR) for posting</u>	<u>January 20, 2021</u>
<u>SAR posted for comment</u>	<u>March 4 – April 2, 2021</u>
<u>45-day formal or informal comment period with ballot</u>	<u>September – November 2022</u>

<u>Anticipated Actions</u>	<u>Date</u>
<u>45-day formal or informal comment period with additional ballot</u>	<u>April – June 2023</u>
<u>10-day final ballot</u>	<u>July 2023</u>
<u>Board adoption</u>	<u>August 2023</u>

New or Modified Term(s) Used in NERC Reliability Standards

This section includes all new or modified terms used in the proposed standard that will be included in the *Glossary of Terms Used in NERC Reliability Standards* upon applicable regulatory approval. Terms used in the proposed standard that are already defined and are not being modified can be found in the *Glossary of Terms Used in NERC Reliability Standards*. The new or revised terms listed below will be presented for approval with the proposed standard. Upon Board adoption, this section will be removed.

Term(s):

None.

A. Introduction

1. **Title:** Verification ~~and Data Reporting of Generator~~ Real and Reactive Power Capability ~~and Synchronous Condenser Reactive Power Capability~~ for BES Facilities
2. **Number:** MOD-~~025-2025-3~~
3. **Purpose:** To ensure that accurate information on ~~generator gross and net~~ Bulk Electric System (BES) Facility Real and ~~Reactive Power capability and synchronous condenser~~ Reactive Power capability is available for planning models used to assess ~~Bulk Electric System (BES)~~ reliability.
4. **Applicability:**
 - 4.1. **Functional ~~entities~~ Entities:**
 - 4.1.1 Generator Owner
 - 4.1.2 Transmission Owner ~~that owns synchronous condenser(s)~~
 - 4.2. **Facilities:**
 - 4.1.3 Transmission Planner
 - 4.2. **Facilities:** For the purpose of this standard, the term, “applicable Facility” or “Facility” shall mean any one of the following:
 - 4.2.1 Individual generating ~~unit greater than 20 MVA (gross nameplate rating) directly connected to the Bulk Electric System~~ resource identified through Inclusion I2 of the BES definition.
 - 4.2.2 ~~Synchronous condenser greater than 20 MVA (gross nameplate rating) directly connected to the Bulk Electric System.~~
 - 4.2.2 Generating plant/Facility identified through Inclusion I2 of the BES definition.
 - 4.2.3 Generating plant/Facility ~~greater than 75 MVA (gross aggregate nameplate rating) directly connected to the Bulk Electric System~~ of dispersed power producing resources identified through Inclusion I4 of the BES definition.
 - 4.2.4 Dynamic reactive devices identified through Inclusion I5 of the BES definition with a gross (individual or aggregate) nameplate rating greater than 20 MVA including, but not limited to:
 - 4.2.4.1 Synchronous condenser; and
 - 4.2.4.2 Flexible alternating current transmission system (FACTS) devices.
 - 4.2.5 High-voltage direct current (HVDC) terminal equipment including:

Standard MOD-025-2025-3 — Verification and Data Reporting of Generator Real and Reactive Power Capability and Synchronous Condenser Reactive Power Capability for BES Facilities

4.2.5.1 Voltage source converter (VSC).

4.2.6 Facilities meeting an exclusion of the BES definition are exempt as an applicable Facility.

5. Effective Date: see Implementation Plan.

B. Requirements and Measures

~~5.1. In those jurisdictions where regulatory approval is required¹:~~

~~5.1.1 By the first day of the first calendar quarter, two calendar years following applicable regulatory approval, or as otherwise made effective pursuant to the laws applicable to such ERO governmental authorities, each Generator Owner and Transmission Owner shall have verified at least 40 percent of its applicable Facilities.~~

~~5.1.2 By the first day of the first calendar quarter, three calendar years following applicable regulatory approval, or as otherwise made effective pursuant to the laws applicable to such ERO governmental authorities, each Generator Owner and Transmission Owner shall have verified at least 60 percent of its applicable Facilities.~~

~~5.1.3 By the first day of the first calendar quarter, four calendar years following applicable regulatory approval, or as otherwise made effective pursuant to the laws applicable to such ERO governmental authorities, each Generator Owner and Transmission Owner shall have verified at least 80 percent of its applicable Facilities.~~

~~5.1.4 By the first day of the first calendar quarter, five calendar years following applicable regulatory approval, or as otherwise made effective pursuant to the laws applicable to such ERO governmental authorities, each Generator Owner and Transmission Owner shall have verified 100 percent of its applicable Facilities.~~

~~5.2. In those jurisdictions where regulatory approval is not required²:~~

~~5.2.1 By the first day of the first calendar quarter, two calendar years following Board of Trustees approval, each Generator Owner and Transmission Owner shall have verified at least 40 percent of its applicable Facilities.~~

~~5.2.2 By the first day of the first calendar quarter, three calendar years following Board of Trustees approval, each Generator Owner and Transmission Owner shall have verified at least 60 percent of its applicable Facilities.~~

~~5.2.3 By the first day of the first calendar quarter, four calendar years following Board of Trustees approval, each Generator Owner and Transmission Owner shall have verified at least 80 percent of its applicable Facilities.~~

¹ ~~Wind Farm Verification — If an entity has two wind sites, and verification of one site is complete, the entity is 50% complete regardless of the number of turbines at each site. A wind site is a group of wind turbines connected at a common point of interconnection or utilizing a common aggregate control system.~~

² ~~Wind farm verification — If an entity has two wind sites, and verification of one site is complete, the entity is 50% complete regardless of the number of turbines at each site. A wind site is a group of wind turbines connected at a common point of interconnection or utilizing a common aggregate control system.~~

Standard MOD-025-2025-3 — Verification and Data Reporting of Generator Real and Reactive Power Capability and Synchronous Condenser Reactive Power Capability for BES Facilities

~~5.2.4~~ By the first day of the first calendar quarter, five calendar years following Board of Trustees approval, each Generator Owner and Transmission Owner shall have verified 100 percent of its applicable Facilities.

~~Note: The verification percentage above is based on the number of applicable units owned.~~

Requirements

R1. Each Generator Owner shall ~~provide its Transmission Planner with verification of~~**verify** the Real Power **and Reactive Power** capability of its applicable Facilities **and inform its Transmission Planner** as follows: *[Violation Risk Factor: Medium] [Time Horizon: Long-term Planning]*

1.1. Verify the Real Power capability, **if applicable**, of its ~~generating units~~**applicable Facilities** in accordance with Attachment 1.

~~1.2. Submit a completed Attachment 2 (or a form containing the same information as identified in Attachment 2) to its Transmission Planner within 90 calendar days of either (i) the date the data is recorded for a staged test; or (ii) the date the data is selected for verification using historical operational data.~~

1.2. Verify the Reactive Power capability of its applicable Facilities in accordance with Attachment 1.

1.3. Submit the following information, in accordance with Attachment 2, to the Transmission Planner within 30 calendar days after the verification date. The verification date, as specified in Attachment 2, should represent the date that the engineering review or engineering analysis is complete. The verification date is the basis of the recurring periodicity.

1.3.1. Simplified one-line diagram representing the applicable Facility;

1.3.2. Composite capability curve and associated PQ data table; and

1.3.3. Documentation of the underlying assumptions, design criteria, and methods for the chosen verification methodology from Attachment 1.

M1. ~~R2.~~ Each Generator Owner shall ~~provide its Transmission Planner with verification of the~~**have evidence that it verified Real Power and** Reactive Power capability of ~~its~~**each** applicable Facilities ~~as follows: [Violation Risk Factor: Medium] [Time Horizon: Long-term Planning]~~

2.1. Facility, such as ~~Verify, in accordance with Attachment 1, (i) the Reactive Power capability of its generating units and (ii) the Reactive Power capability of its synchronous condenser units.~~

~~2.2. Submit a completed Attachment 2 (or a form containing the same information as identified in Attachment 2)~~**attachments or summary report(s); and have evidence that it submitted the information within 30 calendar days after the verification date** to its Transmission Planner ~~within 90 calendar days of either (i) the date the data is recorded for a staged test; or (ii) the date the data is selected for verification using historical operational data~~**in accordance with Requirement R1.**

R2. ~~R3.~~ Each Transmission Owner shall ~~provide its Transmission Planner with verification of the~~**verify the Real Power and** Reactive Power capability of its applicable Facilities **and inform its Transmission Planner** as follows: *[Violation Risk Factor: Medium] [Time Horizon: Long-term Planning]*

- 2.1. Verify the Real Power capability, if applicable, of its applicable Facilities in accordance with Attachment 1.**
- 2.2. ~~3.1.~~ Verify the Reactive Power capability of its applicable Facilities, in accordance with Attachment 1, the Reactive Power capability of its synchronous condenser units.**
- 3.2. Submit a completed Attachment 2 (or a form containing the same information as identified in Attachment 2) to its Transmission Planner within 90 calendar days of either (i) the date the data is recorded for a staged test; or (ii) the date the data is selected for verification using historical operational data.**

B. Measures

- 2.3. Submit the following information, in accordance with Attachment 2, to the Transmission Planner within 30 calendar days after the verification date. The verification date, as specified in Attachment 2, should represent the date that the engineering review or engineering analysis is complete. The verification date is the basis of the recurring periodicity.**
 - 2.3.1. Simplified one-line diagram representing the applicable Facility;**
 - 2.3.2. Composite capability curve and associated PQ data table; and**
 - 2.3.3. Documentation of the underlying assumptions, design criteria, and methods for the chosen verification methodology from Attachment 1.**
- M2. ~~M1.~~ Each Generator Transmission Owner will shall have evidence that it performed the verification, such as a completed Attachment 2 or the Generator Owner form with the same information or dated information collected and used to complete verified Real Power and Reactive Power capability of each applicable Facility, such as completed attachments, or summary report(s); and will have evidence that it submitted the information within 90 30 calendar days after the verification date to its Transmission Planner; such as dated electronic mail messages or mail receipts in accordance with Requirement R1 R2.**
- M2. ~~Each Generator Owner will have evidence that it performed the verification, such as a completed Attachment 2 or the Generator Owner form with the same information, or dated information collected and used to complete attachments and will have evidence that it submitted the information within 90 days to its Transmission Planner; such as dated electronic mail messages or mail receipts in accordance with Requirement R2.~~**
- R3. Each Transmission Planner shall review the information submitted by each Generator Owner or Transmission Owner in accordance with Requirement R1, R2, or R4 and provide a written response to the submitter within 90 calendar days from receiving each submission. The written response shall contain one of the following: [Violation Risk Factor: Lower] [Time Horizon: Operations Planning]**
 - Notification that the Transmission Planner has reviewed the information and has not identified any technical concerns with the Real and Reactive**

Power capability information submitted by the Generator Owner or Transmission Owner; or

- Notification that the Transmission Planner has reviewed the information and has identified a technical concern, including the basis for the technical concern.

M3. Each Transmission Planner shall have evidence, such as a summary of items reviewed and dated correspondence of the notification, that it reviewed the information submitted and provided notification to the Generator Owner or Transmission Owner within 90 calendar days in accordance with Requirement R3.

R4. Each Generator Owner or Transmission Owner receiving a notification of a technical concern under Requirement R3 shall provide a written response to its Transmission Planner within 90 calendar days from receiving a notification. The written response shall contain one of the following: *[Violation Risk Factor: Lower]* *[Time Horizon: Operations Planning]*

- Updated capability information in accordance with Requirement R1 or R2;
- A plan to update the capability information in accordance with Requirement R1 or R2; or
- Technical justification and supporting evidence for maintaining the existing capability information in accordance with Requirement R1 or R2.

M4. ~~M3.~~ Each Generator Owner or Transmission Owner will~~shall~~ have evidence that it performed the verification, such as a completed Attachment 2 or ~~responded to~~ the Transmission Owner form with equivalent information or dated information collected and used to complete attachments, and will have evidence that it submitted the information within 90 days to its Transmission Planner; such as dated electronic mail messages or mail receipts Planner within 90 calendar days in accordance with Requirement ~~R3~~R4.

C. Compliance

1. Compliance Monitoring Process

1.1. Compliance Enforcement Authority

~~“The Regional Entity shall serve as the Compliance enforcement authority unless the applicable entity is owned, operated, or controlled by~~**Enforcement Authority” means NERC or** the Regional Entity.~~In such cases the ERO or a Regional entity approved by FERC or other applicable governmental authority shall serve as the CEA.,~~ **or any entity as otherwise designated by an Applicable Governmental Authority, in their respective roles of monitoring and/or enforcing compliance with mandatory and enforceable Reliability Standards in their respective jurisdictions.**

~~1.2. Evidence Retention~~

1.2. Evidence Retention: The following evidence retention ~~periods~~**period(s)** identify ~~at the~~ period of time an entity is required to retain specific evidence to demonstrate compliance. For instances where the evidence retention **period** specified below is shorter than the time since the last ~~compliance~~ audit, the Compliance Enforcement Authority may ask an entity to provide other evidence to show that it was compliant for the ~~full time~~**full-time** period since the last audit.

The ~~Generator Owner and Transmission Owner shall each~~**applicable entity shall** keep ~~the~~ data or evidence to show compliance as identified below, unless directed by its Compliance Enforcement Authority to retain specific evidence for a longer period of time as part of an investigation:

- ~~The~~**Each** Generator Owner shall ~~retain the latest MOD-025 Attachment 2 and the data behind Attachment 2 or Generator Owner form with equivalent information and submittal evidence for Requirements R1 and R2, Measures M1 and M2 for the time period since the last compliance audit.~~**keep data or evidence of Requirement R1 since the most current verification for each applicable BES Facility.**
- ~~The~~ Transmission Owner shall retain the latest MOD-025 Attachment 2 and the data behind Attachment 2 or Transmission Owner form with equivalent information and submittal evidence for Requirement R3, Measure M3 for the time period since the last compliance audit.
- **Each Transmission Owner shall keep data or evidence of Requirement R2 since the most current verification for each applicable BES Facility.**
- **Each Transmission Planner shall keep data or evidence of Requirement R3 for a rolling 12 month period.**

- ~~If a~~**Each** Generator Owner ~~or~~**and** Transmission Owner ~~is found noncompliant, it shall keep information related to the noncompliance until mitigation is complete or for the time specified above, whichever is longer~~**shall keep data or evidence of Requirement R4 for a rolling 12 month period.**

1.3. The Compliance Monitoring and Enforcement Authority shall keep the last audit records ~~and all requested and submitted subsequent audit records.~~**Program: As defined in the NERC Rules of Procedure, “Compliance Monitoring and Enforcement Program” refers to the identification of the processes that will be used to evaluate data or information for the purpose of assessing performance or outcomes with the associated Reliability Standard.**

1.3. Compliance Monitoring and Assessment Processes

~~Compliance Audit
Self-Certification
Spot Checking
Compliance Investigation
Self-Reporting
Complaint~~

1.4. Additional Compliance Information

~~None~~

Standard MOD-025-2 — Verification and Data Reporting of Generator Real and Reactive Power Capability and Synchronous Condenser Reactive Power Capability

2. Violation Severity Levels

R #	Violation Severity Levels			
R #	Lower VSL	Moderate VSL	High VSL	Severe VSL
R1.	<p>The Generator Owner verified and recorded the Real Power capability of its applicable generating unit, but submitted the data to its Transmission Planner more than 90 calendar days, but within 120 calendar days, of the date the data is recorded for a staged test or the date the data is selected for verification using historical operational data.</p> <p><u>The applicable entity provided all items in Requirement R1 Part 1.3, but did so between 31 and 90 calendar days after the verification date.</u></p>	<p>The Generator Owner verified and recorded the Real Power capability of its applicable generating unit, but submitted the data to its Transmission Planner more than 120 calendar days, but within 150 calendar days, of the date the data is recorded for a staged test or the date the data is selected for verification using historical operational data.</p> <p><u>The applicable entity provided all items in Requirement R1 Part 1.3, but did so between 91 and 180 calendar days after the verification date.</u></p>	<p>The Generator Owner verified and recorded the Real Power capability of its applicable generating unit, but submitted the data to its Transmission Planner more than 150 calendar days, but within 180 calendar days, of the date the data is recorded for a staged test or the date the data is selected for verification using historical operational data.</p> <p><u>The applicable entity provided all items in Requirement R1 Part 1.3, but did so between 181 and 270 calendar days after the verification date.</u></p>	<p>The Generator Owner verified and recorded the Real Power capability of its applicable generating unit, but submitted the data to its Transmission Planner more than 180 calendar days of the date the data is recorded for a staged test or the date the data is selected for verification using historical operational data.</p> <p><u>The applicable entity provided all items in Requirement R1 Part 1.3, but did so greater than 270 calendar days after the verification date.</u></p> <p>OR</p>

Standard MOD-025-2 — Verification and Data Reporting of Generator Real and Reactive Power Capability and Synchronous Condenser Reactive Power Capability

R #	Violation Severity Levels			
R #	Lower VSL	Moderate VSL	High VSL	Severe VSL
	<p>OR</p> <p>The Generator Owner verified the Real Power capability, per Attachment 1 and submitted the data but was missing 1 to less than or equal to 33 percent of the data.</p> <p>OR</p> <p>The Generator Owner performed applicable entity verified the Real and Reactive Power verification capability in Part 1.1 and 1.2, per Attachment 1, “Periodicity for conducting a new verification” item 1 or item 2 (5-year requirement) Section 1 Item 3, but did so in more than 66 between 120 calendar months but less than or equal to 69 and 126 calendar months.</p> <p>OR</p>	<p>OR</p> <p>The Generator Owner applicable entity verified the Real and Reactive Power capability, per Attachment 1 and submitted the data but was missing more than 33 to 66 percent of the data in Part 1.1 and 1.2, but failed to include the information required in Requirement R1, Part 1.3.1.</p> <p>OR</p> <p>The Generator Owner performed applicable entity verified the Real and Reactive Power verification capability in Part 1.1 and 1.2, per Attachment 1, “Periodicity for conducting a new verification” item 1 or item 2 (5-year requirement) Section 1 Item 3, but did so in more than 69 between 127 and 132 calendar months but less than or equal to 72 months.</p>	<p>OR</p> <p>The Generator Owner applicable entity verified the Real and Reactive Power capability, per Attachment 1 and submitted the data but was missing from 67 to 99 percent of the data in Part 1.1 and 1.2, but failed to include the information required in Requirement R1, Part 1.3.3.</p> <p>OR</p> <p>The Generator Owner performed applicable entity verified the Real and Reactive Power verification capability in Part 1.1 and 1.2, per Attachment 1, “Periodicity for conducting a new verification” item 1 or item 2 (5-year requirement) Section 1 Item 3, but did so in more than 72 between 133 and 138 calendar months but less than or equal to 75 months.</p>	<p>The Generator Owner failed to verify applicable entity verified the Real and Reactive Power capability, per Attachment 1 of an applicable generating unit in Part 1.1 and 1.2, but failed to include the information required in Requirement R1, Part 1.3.2.</p> <p>OR</p> <p>The Generator Owner performed applicable entity verified the Real and Reactive Power verification capability in Part 1.1 and 1.2, per Attachment 1, “Periodicity for conducting a new verification” item 1 or item 2 (5-year requirement) Section 1 Item 3, but did so in more than 75 138 calendar months.</p> <p>OR</p> <p>The Generator Owner performed applicable entity verified the Real and Reactive</p>

Standard MOD-025-2 — Verification and Data Reporting of Generator Real and Reactive Power Capability and Synchronous Condenser Reactive Power Capability

R #	Violation Severity Levels			
R #	Lower VSL	Moderate VSL	High VSL	Severe VSL
	<p>The Generator Owner performed <u>applicable entity verified</u> the Real and Reactive Power <u>verification capability in Part 1.1 and 1.2</u>, per Attachment 1, “Periodicity for conducting a new verification” item 1, 2 or 3 (12 calendar month requirement) <u>but did so in more than 12 calendar months but less than or equal to 13 calendar months Section 1 Item 2, 4, or 5, but did so between 181 and 270 calendar days.</u></p>	<p>OR</p> <p>The Generator Owner performed <u>applicabl e entity verified</u> the Real and Reactive Power <u>verification capabilit y in Part 1.1 and 1.2</u>, per Attachment 1; “Periodicity for conducting a new verification” item 1, 2 or 3 (12 calendar month requirement) but did so in more than 13 calendar months but less than or equal to 14 calendar months.</p> <p><u>Section 1 Item 2, 4, or 5, but did so between 271 and 360 calendar days.</u></p>	<p>OR</p> <p>The Generator Owner performed <u>applicabl e entity verified</u> the Real and Reactive Power <u>verification capabilit y in Part 1.1 and 1.2</u>, per Attachment 1; “Periodicity for conducting a new verification” item 1, 2 or 3 (12 calendar month requirement) but did so in more than 14 calendar months but less than or equal to 15 calendar months.</p> <p><u>Section 1 Item 2, 4, or 5, but did so between 361 and 450 calendar days.</u></p>	<p>Power verification <u>capability in Part 1.1 and 1.2</u>, per Attachment 1, “Periodicity for conducting a new verification” item 1, 2 or 3 (12 calendar month requirement) <u>Section 1 Item 2, 4, or 5</u>, but did so in more than 15 <u>450</u> calendar months <u>days</u>.</p> <p><u>OR</u></p> <p><u>The applicable entity failed to verify the Real and/or Reactive Power capability in Part 1.1 and 1.2.</u></p>
R2.	<p>The Generator Owner verified and recorded the</p>	<p>The Generator Owner verified and recorded the</p>	<p>The Generator Owner verified and recorded the</p>	<p>The Generator Owner verified and recorded the</p>

Standard MOD-025-2 — Verification and Data Reporting of Generator Real and Reactive Power Capability and Synchronous Condenser Reactive Power Capability

R #	Violation Severity Levels			
R #	Lower VSL	Moderate VSL	High VSL	Severe VSL
	<p>Reactive Power capability of its applicable generating unit or applicable synchronous condenser, but submitted the data to its Transmission Planner more than 90 calendar days, but within 120 calendar days, of the date the data is recorded for a staged test or the date the data is selected for verification using historical operational data.</p> <p><u>The applicable entity provided all items in Requirement R2 Part 2.3, but did so between 31 and 90 calendar days after the verification date.</u></p> <p>OR</p>	<p>Reactive Power capability of its applicable generating unit or applicable synchronous condenser, but submitted the data to its Transmission Planner more than 120 calendar days, but within 150 calendar days, of the date the data is recorded for a staged test or the date the data is selected for verification using historical operational data.</p> <p><u>The applicable entity provided all items in Requirement R2 Part 2.3, but did so between 91 and 180 calendar days after the verification date.</u></p> <p>OR</p>	<p>Reactive Power capability of its applicable generating unit or applicable synchronous condenser, but submitted the data to its Transmission Planner more than 150 calendar days, but within 180 calendar days, of the date the data is recorded for a staged test or the date the data is selected for verification using historical operational data.</p> <p><u>The applicable entity provided all items in Requirement R2 Part 2.3, but did so between 181 and 270 calendar days after the verification date.</u></p> <p>OR</p>	<p>Reactive Power capability of its applicable generating unit or applicable synchronous condenser, but submitted the data to its Transmission Planner more than 180 calendar days of the date the data is recorded for a staged test or the date the data is selected for verification using historical operational data.</p> <p><u>The applicable entity provided all items in Requirement R2 Part 2.3, but did so greater than 270 calendar days after the verification date.</u></p> <p>OR</p> <p><u>The applicable entity verified the Real and Reactive Power</u></p>

Standard MOD-025-2 — Verification and Data Reporting of Generator Real and Reactive Power Capability and Synchronous Condenser Reactive Power Capability

R #	Violation Severity Levels			
R #	Lower VSL	Moderate VSL	High VSL	Severe VSL
	<p>The Generator Owner<u>applicable entity</u> verified the <u>Real and</u> Reactive Power capability <u>in Part 2.1 and 2.2</u>, per Attachment 1 and submitted the data but was missing 1 to up to and including 33 percent of the data <u>Section 1 Item 3, but did between 120 and 126 calendar months.</u></p> <p>OR</p> <p>The Generator Owner performed the Reactive Power verification per Attachment 1, “Periodicity for conducting a new verification” item 1 or item 2 (5-year requirement) but did so in more than 66 calendar months but less than or equal to 69 months.</p>	<p>The Generator Owner<u>applicable entity</u> verified the <u>Real and</u> Reactive Power capability, per Attachment 1 and submitted the data but was missing 34 to 66 percent of the data <u>in Part 2.1 and 2.2, but failed to include the information required in Requirement R2, Part 2.3.1.</u></p> <p>OR</p> <p><u>The applicable entity verified the Real and Reactive Power capability in Part 2.1 and 2.2, per Attachment 1 Section 1 Item 3, but did so between 127 and 132 calendar months.</u></p> <p>The Generator Owner performed the Reactive Power verification per Attachment 1, “Periodicity for conducting a new verification” item 1 or item 2 (5-year</p>	<p>The Generator Owner<u>applicable entity</u> verified the <u>Real and</u> Reactive Power capability, per Attachment 1 and submitted the data but was missing 67 to 99 percent of the data <u>in Part 2.1 and 2.2, but failed to include the information required in Requirement R2, Part 2.3.3.</u></p> <p>OR</p> <p><u>The applicable entity verified the Real and Reactive Power capability in Part 2.1 and 2.2, per Attachment 1 Section 1 Item 3, but did so between 133 and 138 calendar months.</u></p> <p>The Generator Owner performed the Reactive Power verification per Attachment 1, “Periodicity for conducting a new verification” item 1 or item 2 (5-year</p>	<p><u>capability in Part 2.1 and 2.2, but failed to include the information required in Requirement R2, Part 2.3.2.</u></p> <p>OR</p> <p>The Generator Owner failed to verify the <u>applicable entity</u> verified the <u>Real and</u> Reactive Power capability <u>in Part 2.1 and 2.2</u>, per Attachment 1 of an applicable generating unit or synchronous condenser unit <u>Section 1 Item 3, but did so in more than 138 calendar months.</u></p> <p>OR</p> <p>The Generator Owner performed the <u>applicable entity</u> verified the <u>Real and</u> Reactive Power verification <u>capability in Part 2.1 and 2.2</u>, per Attachment 1, “Periodicity for conducting a new verification” item <u>Section 1</u> or item <u>Item 2 (4, or 5-year requirement),</u> but did</p>

Standard MOD-025-2 — Verification and Data Reporting of Generator Real and Reactive Power Capability and Synchronous Condenser Reactive Power Capability

R #	Violation Severity Levels			
R #	Lower VSL	Moderate VSL	High VSL	Severe VSL
	<p>OR</p> <p>The Generator Owner performed the Reactive Power verification per Attachment 1, “Periodicity for conducting a new verification” item 1, 2 or 3 (12 calendar month requirement) but did so in more than 12 calendar months but less than or equal to 13 calendar months.</p> <p><u>The applicable entity verified the Real and Reactive Power capability in Part 2.1 and 2.2, per Attachment 1 Section 1 Item 2, 4, or 5, but did so between 181 and 270 calendar days.</u></p>	<p>requirement) but did so in more than 69 calendar months but less than or equal to 72 months.</p> <p>OR</p> <p>The Generator Owner performed the Reactive Power verification per Attachment 1, “Periodicity for conducting a new verification” item 1, 2 or 3 (12 calendar month requirement) but did so in more than 13 calendar months but less than or equal to 14 calendar months.</p> <p><u>The applicable entity verified the Real and Reactive Power capability in Part 2.1 and 2.2, per Attachment 1 Section 1 Item 2, 4, or 5, but did so</u></p>	<p>requirement) but did so in more than 72 calendar months but less than or equal to 75 months.</p> <p>OR</p> <p>The Generator Owner performed the Reactive Power verification per Attachment 1, “Periodicity for conducting a new verification” item 1, 2 or 3 (12 calendar month requirement) but did so in more than 14 calendar months but less than or equal to 15 calendar months.</p> <p><u>The applicable entity verified the Real and Reactive Power capability in Part 2.1 and 2.2, per Attachment 1 Section 1 Item 2, 4, or 5, but did so</u></p>	<p>so in more than 75<u>450</u> calendar months<u>days</u>.</p> <p>OR</p> <p>The Generator Owner performed the Reactive Power verification per Attachment 1, “Periodicity for conducting a new verification” item 1, 2 or 3 (12 calendar month requirement) but did so in more than 15 calendar months.</p> <p><u>The applicable entity failed to verify the Real and/or Reactive Power capability in Part 2.1 and 2.2.</u></p>

Standard MOD-025-2 — Verification and Data Reporting of Generator Real and Reactive Power Capability and Synchronous Condenser Reactive Power Capability

R #	Violation Severity Levels			
R #	Lower VSL	Moderate VSL	High VSL	Severe VSL
		<u>between 271 and 360 calendar days.</u>	<u>between 361 and 450 calendar days.</u>	
R3.	<u>The Transmission Planner provided a written response to the submitter, but it was provided between 91 to 120 calendar days after receiving the verified model information.</u>	<u>The Transmission Planner provided a written response to the submitter, but it was provided between 121 to 150 calendar days after receiving the verified model information.</u>	<u>The Transmission Planner provided a written response to the submitter, but it was provided between 151 to 180 calendar days after receiving the verified model information.</u>	<u>The Transmission Planner failed to provide a written response to the submitter.</u> OR <u>The Transmission Planner provided a written response to the submitter but it was provided more than 180 calendar days after receiving the verified model information.</u>
R3R4.	The Transmission Owner verified and recorded the Reactive Power capability of its applicable synchronous condenser, but submitted the data to its Transmission Planner more than 90 calendar days, but within 120 calendar days, of	The Transmission Owner verified and recorded the Reactive Power capability of its applicable synchronous condenser, but submitted the data to its Transmission Planner more than 120 calendar days, but within 150 calendar days, of	The Transmission Owner verified and recorded the Reactive Power capability of an applicable synchronous condenser unit, but submitted the data to its Transmission Planner more than 150 calendar days, but within 180 calendar days, of	The Transmission Owner verified and recorded the Reactive Power capability of its applicable synchronous condenser, but submitted the data to its Transmission Planner more than 180 calendar days of the date the data is recorded for a

Standard MOD-025-2 — Verification and Data Reporting of Generator Real and Reactive Power Capability and Synchronous Condenser Reactive Power Capability

R #	Violation Severity Levels			
R #	Lower VSL	Moderate VSL	High VSL	Severe VSL
	<p>the date the data is recorded for a staged test or the date the data is selected for verification using historical operational data.</p> <p>OR</p> <p>The Transmission Owner verified the Reactive Power capability, per Attachment 1 and submitted the data but was missing 1 to up to and including 33 percent of the data.</p> <p>OR</p> <p>The Transmission Owner performed the Reactive Power verification per Attachment 1, “Periodicity for conducting a new</p>	<p>the date the data is recorded for a staged test or the date the data is selected for verification using historical operational data.</p> <p>OR</p> <p>The Transmission Owner verified the Reactive Power capability, per Attachment 1 and submitted the data but was missing 34 to 66 percent of the data.</p> <p>OR</p> <p>The Transmission Owner performed the Reactive Power verification per Attachment 1, “Periodicity for conducting a new verification” item 1</p>	<p>the date the data is recorded for a staged test or the date the data is selected for verification using historical operational data.</p> <p>OR</p> <p>The Transmission Owner verified the Reactive Power capability, per Attachment 1 and submitted the data but was missing 67 to 99 percent of the data.</p> <p>OR</p> <p>The Transmission Owner performed the Reactive Power verification per Attachment 1, “Periodicity for conducting a new verification” item 1</p>	<p>staged test or the date the data is selected for verification using historical operational data.</p> <p><u>The applicable entity failed to provide a written response to its Transmission Planner.</u></p> <p>OR</p> <p>The Transmission Owner failed to verify the Reactive Power capability, per Attachment 1 of an applicable synchronous condenser unit.</p> <p>OR</p> <p>The Transmission Owner performed the verification per Attachment 1, “Periodicity for conducting a new verification” item 1</p>

Standard MOD-025-2 — Verification and Data Reporting of Generator Real and Reactive Power Capability and Synchronous Condenser Reactive Power Capability

R #	Violation Severity Levels			
R #	Lower VSL	Moderate VSL	High VSL	Severe VSL
	<p>verification” item 1 or item 2 (5-year requirement) but did so in more than 66 calendar months but less than or equal to 69 months.</p> <p>OR</p> <p>The Transmission Owner performed the Reactive Power verification per Attachment 1, “Periodicity for conducting a new verification” item 1, 2 or 3 (12-calendar month requirement) but did so in more than 12 calendar months but less than or equal to 13 calendar months. <u>The applicable entity provided a written response to its Transmission Planner, but it was provided between 91 to 120 calendar days after receiving a notification of technical concern.</u></p>	<p>or item 2 (5-year requirement) but did so in more than 69 calendar months but less than or equal to 72 months.</p> <p>OR</p> <p>The Transmission Owner performed the Reactive Power verification per Attachment 1, “Periodicity for conducting a new verification” item 1, 2 or 3 (12-calendar month requirement) but did so in more than 13 calendar months but less than or equal to 14 calendar months.</p> <p><u>The applicable entity provided a written response to its Transmission Planner, but it was provided between 121 to</u></p>	<p>or item 2 (5-year requirement) but did so in more than 72 calendar months but less than or equal to 75 months.</p> <p>OR</p> <p>The Transmission Owner performed the Reactive Power verification per Attachment 1, “Periodicity for conducting a new verification” item 1, 2 or 3 (12-calendar month requirement) but did so in more than 14 calendar months but less than or equal to 15 calendar months.</p> <p><u>The applicable entity provided a written response to its Transmission Planner, but it was provided between 151 to</u></p>	<p>or item 2 (5-year requirement) but did so in more than 75 calendar months.</p> <p>OR</p> <p>The Transmission Owner performed the Reactive Power verification per Attachment 1, “Periodicity for conducting a new verification” item 1, 2 or 3 (12-calendar month requirement) but did so in more than 15 calendar months.</p> <p><u>The applicable entity provided a written response to its Transmission Planner, but it was provided greater than 180 calendar days after receiving a notification of technical concern.</u></p>

Standard MOD-025-2 — Verification and Data Reporting of Generator Real and Reactive Power Capability and Synchronous Condenser Reactive Power Capability

<u>R #</u>	<u>Violation Severity Levels</u>			
<u>R #</u>	Lower VSL	Moderate VSL	High VSL	Severe VSL
		<u>150 calendar days after receiving a notification of technical concern.</u>	<u>180 calendar days after receiving a notification of technical concern.</u>	

D. Regional Variances

None.

E. Associated Documents

Reliability Guideline Power Plant Model Verification and Testing for Synchronous Machines, July 2018.

NATF Reporting and Verification of Generating Unit Reactive Power Capability for Synchronous Machines Reference, September 2020.

Version History

Version	Date	Action	Change Tracking
1	12/1/2005	<ol style="list-style-type: none"> 1. Changed tabs in footer. 2. Removed comma after 2004 in “Development Steps Completed,” #1. 3. Changed incorrect use of certain hyphens (-) to “en dash” (–) and “em dash (—).” 4. Added “periods” to items where appropriate. 5. Changed apostrophes to “smart” symbols. 6. Changed “Timeframe” to “Time Frame” in item D, 1.2. 7. Lower cased all instances of “regional” in section D.3. 8. Removed the word “less” after 94% in section 3.4. Level 4. 	01/20/06
2	February 7, 2013	Adopted by NERC Board of Trustees	Revised per SAR for Project 2007-09 and combined with MOD-024-1
2	March 20, 2014	FERC Order issued approving MOD-025-2. (Order becomes effective on 7/1/16.)	
<u>3</u>	<u>TBD</u>	<u>Adopted by NERC Board of Trustees</u>	<u>Revised per SAR for Project 2021-01</u>

~~MOD-025 Attachment 1—Verification of Generator Real and Reactive Power Capability and Synchronous Condenser Reactive Power Capability~~

MOD-025-3 Attachment 1

Section I. Periodicity for conducting a new of verification:

The periodicity ~~for performing~~**to verify the** Real and Reactive Power capability ~~verification~~**for each applicable BES Facility** is as follows:

- ~~1. For staged verification; verify each applicable Facility at least every five years (with no more than 66 calendar months between verifications), or within 12 calendar months of the discovery of a change that affects its Real Power or Reactive Power capability by more than 10 percent of the last reported verified capability and is expected to last more than six months. The first verification for each applicable Facility under this standard must be a staged test.~~
 - ~~2. For verification using operational data; verify each applicable Facility at least every five years (with no more than 66 calendar months between verifications), or within 12 calendar months following the discovery that its Real Power or Reactive Power capability has changed by more than 10 percent of the last reported verified capability and is expected to last more than six months. If data for different points is recorded on different days, designate the earliest of those dates as the verification date, and report that date as the verification date on MOD-025, Attachment 2 for periodicity purposes.~~
 - ~~3. For either verification method, verify each new applicable Facility within 12 calendar months of its commercial operation date. Existing units that have been in long term shut down and have not been tested for more than five years shall be verified within 12 calendar months.~~
- 1. The applicable entity designates the verification date and notates the verification date in a summary report (refer to Attachment 2). The verification date should represent the date that the engineering review or engineering analysis is complete. The verification date is the basis of the recurring periodicity.**
 - 2. Verify each new applicable Facility within 180 calendar days of its commercial operation date.**
 - 3. Verify each existing applicable Facility at a periodicity not to exceed 120 calendar months from the last verification date, unless it meets the following condition:**
 - The Facility has been on a planned or unplanned outage of 180 days or greater, which overlaps its scheduled verification date. Verify the applicable Facility within 180 calendar days of its return to service date.**
 - 4. Verify an existing applicable Facility within 180 calendar days of the discovery of a change that affects its Real Power or Reactive Power capability by more than a 10 percent increase or decrease of the nameplate rating and is expected to last more than 180 calendar days.**

~~It is intended that Real Power testing be performed at the same time as full load Reactive Power testing, however separate testing is allowed for this standard. For synchronous condensers, perform only the Reactive Power capability verifications as specified below.~~

~~If the Reactive Power capability is verified through test, it is to be scheduled at a time advantageous for the unit being verified to demonstrate its Reactive Power capabilities while the Transmission Operator takes measures to maintain the plant's system bus voltage at the scheduled value or within acceptable tolerance of the scheduled value.~~

Section II. Verification specifications for applicable Facilities:

1. ~~For generating units of 20 MVA or less that are part of a plant greater than 75 MVA in aggregate, record data either on an individual unit basis or as a group. Perform verification individually for every generating unit or synchronous condenser~~**individual devices or generators** greater than 20 MVA (gross nameplate rating) **perform verification on an individual basis.**
2. ~~Verify with all auxiliary equipment needed for expected normal operation in service for both the Real Power and Reactive Power capability verification. Perform verification with the automatic voltage regulator in service for the Reactive Power capability verification. Operational data from within the two years prior to the verification date is acceptable for the verification of either the Real Power or the Reactive Power capability, as long as a) that operational data meets the criteria in 2.1 through 2.4 below and b) the operational data demonstrates at least 90 percent of a previously staged test that demonstrated at least 50 percent of the Reactive capability shown on the associated thermal capability curve (D-curve). If the previously staged test was unduly restricted (so that it did not demonstrate at least 50 percent of the associated thermal capability curve) by unusual generation or equipment limitations (e.g., capacitor or reactor banks out of service), then the next verification will be by another staged test, not operational data:~~
 - 2.1. ~~Verify Real Power capability and Reactive Power capability over excited (lagging) of all applicable Facilities at the applicable Facilities' normal (not emergency) expected maximum Real Power output at the time of the verifications.~~
2. **For individual devices or generators 20 MVA (gross nameplate rating) or less that are part of an applicable Facility greater than 75 MVA (gross nameplate rating) in aggregate, perform verification on an individual unit basis or in the aggregate, considering applicable modeling expectations of the respective Transmission Planner.**
3. **Create a simplified one-line diagram representing the Facility (refer to Attachment 2). Identify on the one-line diagram where the composite capability curve created in Section II, Items 6-8 is represented.**
 - 3.1. **The simplified one-line diagram representing the Facility shall represent all auxiliary equipment expected to be in-service for normal operation, including dynamic and static reactive devices and auxiliary load, the generator step-up**

(GSU), and/or system interconnection transformer(s), unit auxiliary transformer(s), and station services auxiliary transformer(s).

4. If an applicable Facility has no leading or lagging capability, then it should be reported with no leading or lagging capability.
5. The Generator Owner or Transmission Owner shall utilize and document one or more of the following methodologies to verify the Facility Real and Reactive Power capability for all equipment expected to be in-service for normal operation. The engineering analysis or engineering review documentation shall include the underlying assumptions, design criteria, and methods used to create the Facility's composite capability curve under Section II, Items 6-8.
 - Utilize staged testing data, in accordance with Section III, obtained from a date within 365 calendar days prior to verification date, and perform engineering analysis as needed per Note 1, that validates the Facility capability; or
 - Utilize operational data, in accordance with Section III, obtained from a date within 365 calendar days prior to verification date, and perform engineering analysis as needed per Note 1, that validates the Facility capability; or
 - Perform an engineering review of all Real and Reactive Power Facility capability information including, but not limited to, in-service equipment design limitations, excitation limiter settings, and operational limitations.
6. For an applicable Facility as identified in Section 4.2.1, 4.2.2, or 4.2.4.1, when performing verification on an individual unit basis, create a graphical representation of the steady-state composite capability curve (CCC) for the Real Power and Reactive Power. The steady-state CCC shall include at a minimum the following:
 - 6.1. The generator nameplate steady-state Real Power and Reactive Power capability curve, or the synchronous condenser nameplate steady-state Reactive Power capability curve, provided by the equipment manufacturer. If the equipment manufacturer curve is not available, the curve shall be derived using the best available data.
 - 6.1.1 The curve shall represent generator/synchronous condenser capability at a nominal voltage of 1.0 per unit at the generator/synchronous condenser terminal; and
 - 6.1.2 The curve shall notate the operating conditions that dictate the power capability, for example H2 pressure, ambient temperature, or other conditions.
 - 6.2. Excitation limiters, if more restrictive than the equipment nameplate capability curve, at nominal voltage 1.0 per unit;

- 6.3. Identification of any Real Power or Reactive Power operational limitations,¹ if applicable;
- 6.4. Identification of the steady-state minimum (P_{min}) and maximum (P_{max}) Real Power output at the generator terminal(s), based on the least restrictive seasonal or operating conditions; and
- 6.5. Identification of final PQ curve, which defines the normal operating region.
7. For an applicable Facility as identified in Section 4.2.2 or Section 4.2.3, when performing verification in aggregate, create a graphical representation of the steady-state composite capability curve (CCC) for the Real Power and Reactive Power. The steady-state CCC shall include at a minimum the following:
 - 7.1. The steady-state Real and Reactive Power capability curve represented as an aggregate.
 - 7.1.1 The curve shall represent Facility capability at a steady-state nominal voltage of 1.0 per unit at the common point of connection; and
 - 7.1.2 The curve shall notate the operating conditions that dictate the power capability, for example H2 pressure, ambient temperature, or other conditions.
 - 7.2. Aggregate Facility capability includes all auxiliary equipment expected to be in-service for normal operation, including dynamic and static reactive resources and auxiliary loads;
 - 7.3. Identification of any Real Power or Reactive Power operational limitations, if applicable;
 - 7.4. For inverter based resources, a description of all power plant controller and inverter control functions during normal operating conditions that dictate the aggregate Facility capability;
 - 7.5. Identification of the steady-state minimum (P_{min}) and maximum (P_{max}) Real Power output at the common point of connection, based on the least restrictive seasonal or operating conditions; and
 - 7.6. Identification of final PQ curve, which defines the normal operating region.
8. For an applicable Facility as identified in Section 4.2.4.2 and Section 4.2.5.1, create a graphical representation of the steady-state composite capability curve (CCC) for the Real Power and Reactive Power. The steady-state CCC shall include at a minimum the following:

¹ Such as generator cooling, vibration, de-rated rotor, de-rated GSU transformer, generator bus de-rating, software limitations, or distributed control system (DCS) setpoints (outer-loop control system paths). This excludes fuel availability, such as water levels for hydro, cloud cover for PV, wind speed, or river level for run of river.

- 8.1. The HVDC nameplate steady-state Real Power and Reactive Power capability curve, or the FACTS device steady-state Reactive Power capability, provided by the equipment manufacturer. If the equipment manufacturer curve is not available, the curve shall be derived using the best available data.
 - 8.1.1 The curve shall represent Facility capability at a steady-state nominal voltage of 1.0 per unit at the common point of connection; and
 - 8.1.2 The curve shall notate the operating conditions that dictate the power capability, for example ambient temperature or other conditions.
- 8.2. Any limiters, if more restrictive than the equipment nameplate capability curve(s), at nominal voltage 1.0 per unit;
- 8.3. Identification of any Real Power or Reactive Power operational limitations, if applicable;
- 8.4. A description of all control functions during normal operating conditions and a description of any Facility overload capabilities that dictate the aggregate Facility capability;
- 8.5. Identification of the steady-state minimum (P_{min}) and maximum (P_{max}) Real Power output at the common point of connection, based on the least restrictive seasonal or operating conditions; and
- 8.6. Identification of final PQ curve, which defines the normal operating region.
 - 2.1.1 Verify synchronous generating unit's maximum real power and lagging reactive power for a minimum of one hour.

Section III. Staged test and operational data specifications:

1. Section III applies when a staged test and/or operational data verification methodology is utilized. If utilizing multiple methodologies to verify the Facility capability, not all data points outlined in Section III, Item 6, 7, 8, or 9 need to be recorded.
2. Record any staged test or operational data in Attachment 3 (or a form containing the same information). If metering does not exist to measure specific values listed in Attachment 3, provide an engineering estimate and associated calculations. Refer to the associated labels depicted in the one-line diagram created in Section II, Item 3. Record any additional data deemed necessary to perform engineering analysis per Note 1.
3. Staged testing or operating conditions should be maintained constant for a sufficient time in order to ensure that the applicable Facility can perform at that level of Real and Reactive Power during steady-state conditions.
4. All auxiliary equipment is expected to be in service for normal operation.
5. The Facility voltage/Reactive power control equipment is in the normal mode of operation.

- 6. For an applicable Facility with Real Power capability, not meeting the criteria of Section III, Part 7, 8 or 9, record measurements at the following four points:**
 - 6.1. Maximum lagging Reactive Power at maximum Real Power until a limit is reached;²**
 - 6.2. Maximum leading Reactive Power at maximum Real Power until a limit is reached;**
 - 6.3. Maximum lagging Reactive Power at minimum Real Power until a limit is reached;**
 - 6.4. Maximum leading Reactive Power at minimum Real Power until a limit is reached.**
- 7. For an applicable Facility with no Real Power capability, record measurements at the following two points (one over-excited point and one under-excited point):**
 - 7.1. Maximum lagging Reactive Power until a limit is reached;**
 - 7.2. Maximum leading Reactive Power until a limit is reached.**
- 8. For an applicable Facility with equal minimum and maximum Real Power output during normal operation, such as a nuclear unit, record measurements at the two points in Items 8.1 and 8.2 below. The Facility need only perform staged testing or provide operational data for Reactive Power at maximum Real Power output. If applicable, provide the theoretical Reactive Power capability at minimum Real Power output in accordance with Attachment 2.**
 - 8.1. Maximum lagging Reactive Power at normal operating Real Power until a limit is reached;**
 - 8.2. Maximum leading Reactive Power at normal operating Real Power until a limit is reached.**
- 9. 2.1.2 Verify For variable generating units/resources, such as wind, solar, and run-of-river hydro, or run-of-river hydro, and non-variable generating resources, such as battery energy storage systems, staged testing or operational data should be recorded with at least 90 percent of the inverters/generators at a Facility on-line. If staged testing or operational data capture of a Facility cannot be accomplished while meeting the 90 percent inverter/generator threshold, document the reason(s) the threshold was not met and test to the full available capability at the time of the test. Maintain, as steady as practical, the maximum Real Power output that the resource can provide at the time of the verification. Record measurements at the two points in Items 9.1 and 9.2 below at the maximum Real Power output the variable resource can provide at the time of the verification. Perform verification of**

² In addition, consider steady state thermal or mechanical limitations of Facility equipment to determine whether it limits the Reactive Power capability during a staged test.

~~Reactive Power capability of wind turbines and photovoltaic inverters with at least 90 percent of the wind turbines or photovoltaic inverters at a site on-line. If verification of wind turbines or photovoltaic inverter Facility cannot be accomplished meeting the 90 percent threshold, document the reasons the threshold was not met and test to the full capability at the time of the test. Reschedule the test of the facility within six months of being able to reach the 90 percent threshold. Maintain, as steady as practical, Real and Reactive Power output during verifications. staged test or operational data.~~

9.1. Maximum lagging Reactive Power at normal operating Real Power until a limit is reached;

~~2.2. Verify Reactive Power capability of all applicable Facilities, other than wind and photovoltaic, for maximum overexcited (lagging) and under-excited (leading) reactive capability for the following conditions:~~

~~2.2.1 At the minimum Real Power output at which they are normally expected to operate collect maximum leading and lagging reactive values as soon as a limit is reached.~~

9.2. 2.2.2 At maximum Maximum leading Reactive Power at normal operating Real Power output collect maximum leading reactive values as soon as until a limit is reached.

~~2.2.3 Nuclear Units are not required to perform Reactive Power verification at minimum Real Power output.~~

~~2.3. For hydrogen-cooled generators, perform the verification at normal operating hydrogen pressure.~~

~~2.4. Calculate the Generator Step-Up (GSU) transformer losses if the verification measurements are taken from the high side of the GSU transformer. GSU transformer real and reactive losses may be estimated, based on the GSU impedance, if necessary.~~

3. Record the following data for the verifications specified above:

~~3.1. The value of the gross Real and Reactive Power generating capabilities at the end of the verification period.~~

~~3.2. The voltage schedule provided by the Transmission Operator, if applicable.~~

~~3.3. The voltage at the high and low side of the GSU and/or system interconnection transformer(s) at the end of the verification period. If only one of these values is metered, the other may be calculated.~~

~~3.4. The ambient conditions, if applicable, at the end of the verification period that the Generator Owner requires to perform corrections to Real Power for different ambient conditions such as:~~

- ~~• Ambient air temperature~~
- ~~• Relative humidity~~

Standard MOD-025-2025-3 — Verification and Data Reporting of Generator Real and Reactive Power Capability and Synchronous Condenser Reactive Power Capability for BES Facilities

- Cooling water temperature
 - Other data as determined to be applicable by the Generator Owner to perform corrections for ambient conditions.
- ~~3.5. The date and time of the verification period, including start and end time in hours and minutes.~~
- ~~3.6. The existing GSU and/or system interconnection transformer(s) voltage ratio and tap setting.~~
- ~~3.7. The GSU transformer losses (real or reactive) if the verification measurements were taken from the high side of the GSU transformer.~~
- ~~3.8. Whether the test data is a result of a staged test or if it is operational data.~~
- ~~4. Develop a simplified key one-line diagram (refer to MOD-025, Attachment 2) showing sources of auxiliary Real and Reactive Power and associated system connections for each unit verified. Include GSU and/or system Interconnection and auxiliary transformers. Show Reactive Power flows, with directional arrows.~~
- ~~4.1. If metering does not exist to measure specific Reactive auxiliary load(s), provide an engineering estimate and associated calculations. Transformer Real and Reactive Power losses will also be estimates or calculations. Only output data are required when using a computer program to calculate losses or loads.~~
- ~~5. If an adjustment is requested by the Transmission Planner, then develop the relationships between test conditions and generator output so that the amount of Real Power that can be expected to be delivered from a generator can be determined at different conditions, such as peak summer conditions. Adjust MW values tested to the ambient conditions specified by the Transmission Planner upon request and submit them to the Transmission Planner within 90 days of the request or the date the data was recorded/selected whichever is later.~~

Note 1: Under ~~some~~**restrictive** transmission system conditions, the data points obtained ~~by the Mvar verification required by the standard will~~**from a staged test or operational data might** not duplicate the manufacturer supplied thermal capability curve (D-curve). ~~However, the verification required by the standard, even when conducted under these transmission system conditions, may uncover applicable Facility limitations; such as rotor thermal instability, improper tap settings or voltage ratios, inaccurate AVR operation, etc., which could be further analyzed for resolution. The Mvar limit level(s) achieved during a staged test or from operational data may not be representative of the unit's~~**When the applicable Facility's** reactive capability ~~for extreme system conditions. See Note 2.~~

~~is~~ Note 2: While not required by the standard, it is desirable to ~~not fully demonstrated,~~ perform **a simulation or** engineering ~~analyses~~**analysis** to determine expected ~~applicable Facility capabilities~~**capability** under less restrictive system voltages ~~than those encountered during the verification.~~ Even though this analysis will not verify the complete thermal capability curve (D-curve), it provides a reasonable estimate of applicable Facility capability that the Transmission Planner can use for modeling.

Standard MOD-025-2025-3 — Verification and Data Reporting of Generator Real and Reactive Power Capability and Synchronous Condenser Reactive Power Capability for BES Facilities

~~Note 3: The Reactive Power verification is intended to define the limits of the unit's Reactive Power capabilities. If a unit has no leading capability, then it should be reported with no leading capability; or the minimum lagging capability at which it can operate.~~

~~Note 4: Synchronous Condensers only need to be tested at two points (one over-excited point and one under-excited point) since they have no Real Power output.~~

MOD-025-025-3 Attachment 2 – BES Facility Capability Report

A completed report shall contain the following information at a minimum per Requirement R1 and R2:

- **Section I: One-line diagram of the applicable Facility**
- **Section II: Composite capability curve and associated PQ data table**
- **Section III: Documentation showing the engineering basis and verification methodology**

An example report is provided below. The report may vary based on the Facility being represented.

Company:

Reported By (name):

Plant:

Unit No.:

Verification Date:

Section I. Provide simplified one-line diagram representing the applicable Facility showing plant auxiliary Load connections. Identify on the one-line diagram where the composite capability curve is represented.

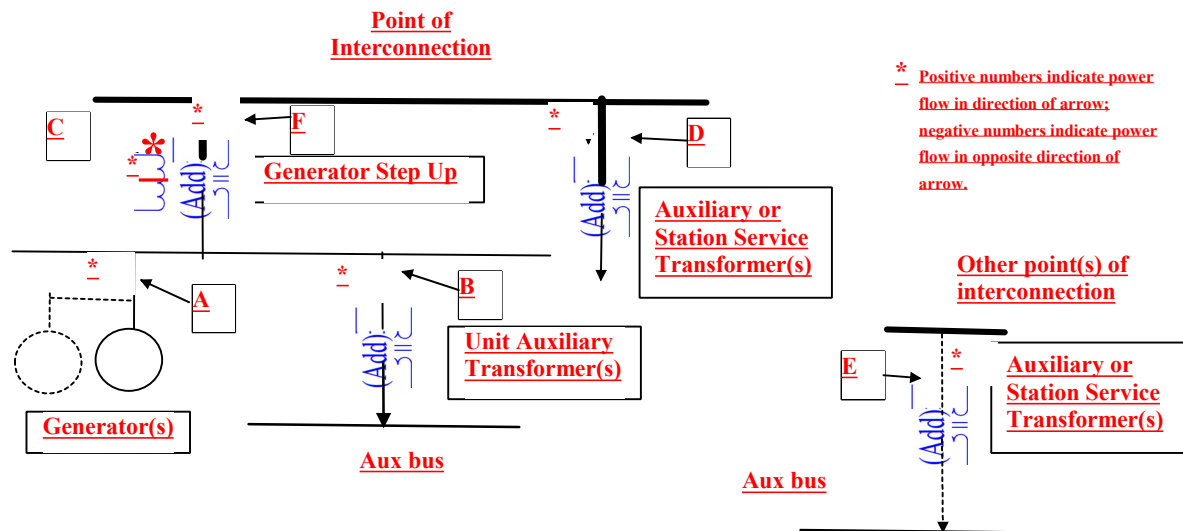

Section II. Provide composite capability curve as defined in Attachment 1, Section II, with associated PQ curve data table.

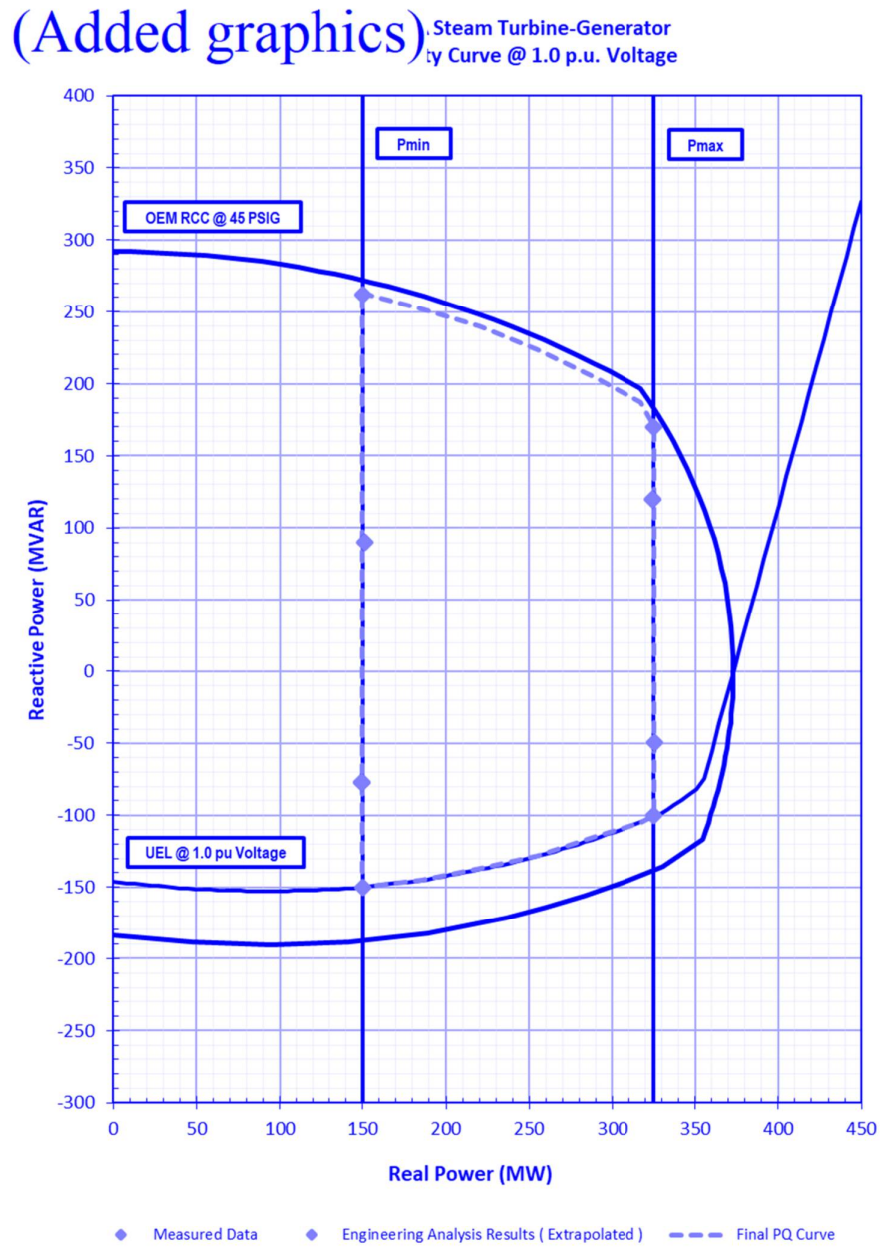

Figure 1: Example Composite Capability Curve for Synchronous Generator

Standard MOD-025-2025-3 — Verification and Data Reporting of Generator Real and Reactive Power Capability and Synchronous Condenser Reactive Power Capability for BES Facilities

	<u>P (MW)</u>	<u>Qmin (MVar)</u>	<u>Qmax (MVar)</u>	<u>Qmin Limit</u>	<u>Qmax Limit</u>
<u>Pmin</u>	<u>150.0</u>	<u>-150.0</u>	<u>263.0</u>	<u>UEL @ 1.0 Vterm</u>	<u>I_{fd} Rated</u>
<u>Pmin + 20% of range</u>	<u>185.0</u>	<u>-145.0</u>	<u>252.0</u>	<u>UEL @ 1.0 Vterm</u>	<u>I_{fd} Rated</u>
<u>Pmin + 40% of range</u>	<u>220.0</u>	<u>-137.0</u>	<u>240.0</u>	<u>UEL @ 1.0 Vterm</u>	<u>I_{fd} Rated</u>
<u>Pmin + 60% of range</u>	<u>255.0</u>	<u>-128.0</u>	<u>224.0</u>	<u>UEL @ 1.0 Vterm</u>	<u>I_{fd} Rated</u>
<u>Pmin + 80% of range</u>	<u>290.0</u>	<u>-115.0</u>	<u>204.0</u>	<u>UEL @ 1.0 Vterm</u>	<u>I_{fd} Rated</u>
<u>Breakpoint</u>	<u>317.1</u>	<u>-105.0</u>	<u>187.0</u>	<u>UEL @ 1.0 Vterm</u>	<u>I_{fd} Rated</u>
<u>Pmax</u>	<u>325.0</u>	<u>-100.0</u>	<u>170.0</u>	<u>UEL @ 1.0 Vterm</u>	<u>I_{fd} Rated</u>

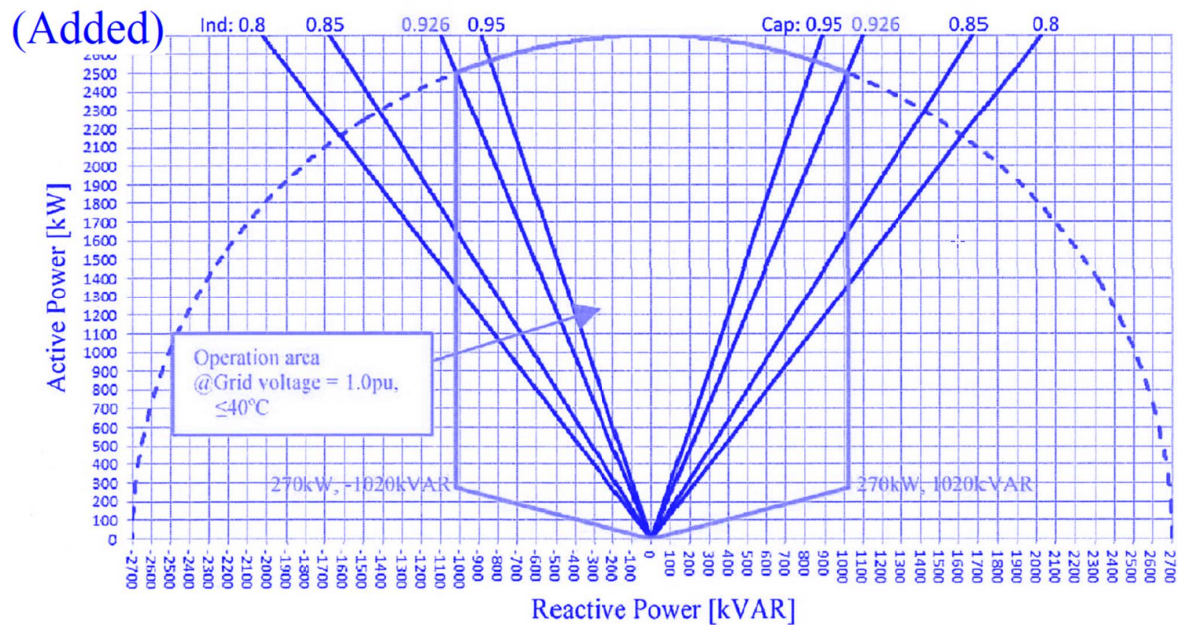

Figure 2: Example Composite Capability Curve for IBR Unit

Standard MOD-025-2025-3 — Verification and Data Reporting of Generator Real and Reactive Power Capability and Synchronous Condenser Reactive Power Capability for BES Facilities

PQ Curve Data Table (template)

<u>Description</u>	<u>Pmax (MW)</u>	<u>Qmax (MVAR)</u>	<u>Qmin (MVAR)</u>	<u>Qmax Limiting Factor</u>	<u>Qmin Limiting Factor</u>
<u>Pmin</u>					
<u>Pmin + (0.20*Range)</u> <u>Range = (Pman - Pmin)</u>					
<u>Pmin + (0.40*Range)</u>					
<u>Pmin + (0.60*Range)</u>					
<u>Pmin + (0.80*Range)</u>					
<u>Pmax</u>					
<u>Additional data points such as breakpoints are optional.</u>					

1. Limiting factor: UEL/OEL, field current rating, distributed control system (DCS) limit, etc.

Section III. Supplemental documentation of verification methodology.

MOD-025-3 Attachment 3

One-line Diagram, Data Table, and Summary for Verification Information Reporting of Staged Test or Operational Data

Note: Reference Attachment 2 one-line diagram measurement points and direction of flow arrows when recording Real and Reactive Power in data table. If the configuration of the applicable Facility does not lend itself to the use of the diagram, tables, or summaries for reporting the required information, changes may be made to this form, provided that all required information (identified in MOD-025, Attachment 1) is reported.

Company:

Reported By (name):

Plant:

Unit No.:

Date of Report:

Check all that apply:

- Over-excited **Full Maximum** Load Reactive Power Verification
- Under-excited **Full Maximum** Load Reactive Power Verification
- Over-excited Minimum Load Reactive Power Verification
- Under-excited Minimum Load Reactive Power Verification
- Real Power Verification
- Staged Test Data
- Operational Data

Data Table for Recording Measurements

Simplified one-line diagram showing plant auxiliary Load connections and verification data:

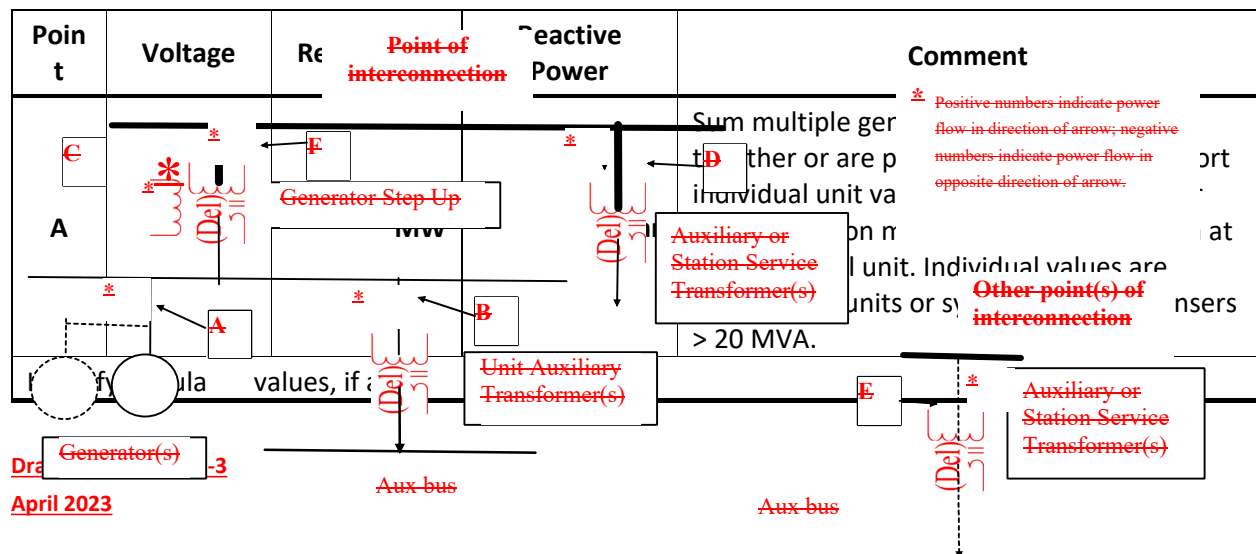

Standard MOD-025-2025-3 — Verification and Data Reporting of Generator Real and Reactive Power Capability and Synchronous Condenser Reactive Power Capability for BES Facilities

B	kV	MW	Mvar	Sum multiple unit auxiliary transformers.
Identify calculated values, if any:				
C	kV	MW	Mvar	Sum multiple tertiary Loads, if any.
Identify calculated values, if any:				
D	kV	MW	Mvar	Sum multiple auxiliary and station service transformers.
Identify calculated values, if any:				
E	kV	MW	Mvar	If multiple points of Interconnection, describe these for accurate modeling; report points individually (sum multiple auxiliary transformers).
F	kV	MW	Mvar	Net unit capability
Identify calculated values, if any:				

Standard MOD-025-2025-3 — Verification and Data Reporting of Generator Real and Reactive Power Capability and Synchronous Condenser Reactive Power Capability for BES Facilities

MOD-025 Attachment 2 (continued)

Verification Data

Provide data by unit or Facility, as appropriate

Data Type	Data Recorded	Last Verification (Previous Data; will be blank for the initial verification)
Gross Reactive Power Capability (*Mvar)		
Aux Reactive Power (*Mvar)		
Net Reactive Power Capability (*Mvar) equals Gross Reactive Power Capability (*Mvar) minus Aux Reactive Power connected at the same bus (*Mvar) minus tertiary Reactive Power connected at the same bus(*Mvar)		
Gross Real Power Capability (*MW)		
Aux Real Power (*MW)		
Net Real Power Capability (*MW) equals Gross Real Power Capability (*MW) minus Aux Real Power connected at the same bus (*MW) minus tertiary Real Power connected at the same bus(*MW)		
* Note: Enter values at the end of the verification period.		
GSU losses (only required if verification measurements are taken on the high side of the GSU—Mvar)		

Summary of ~~Verification~~ Test / Operational Data

- **Date of Staged Test (or oldest Date of Operational Data):** _____
- Date of Verification _____, Verification Start Time _____, ~~Verification~~ End Time _____, **Staged Test or Operational Data** _____
 - Scheduled Voltage _____
- Transformer Voltage Ratio: GSU _____, Unit Aux _____, Station Aux _____, Other Aux _____
- Transformer Tap Setting: GSU _____, Unit Aux _____, Station Aux _____, Other Aux _____
- **Transformer Impedance: GSU _____ ; Transformer X/R ratio: GSU _____**
- **Generator or Exciter Field Current (synchronous only): Start _____, End _____**
- Ambient conditions at the end of the verification period:
 - Air **or inlet** temperature: _____

Standard MOD-025-2025-3 — Verification and Data Reporting of Generator Real and Reactive Power Capability and Synchronous Condenser Reactive Power Capability for BES Facilities

Humidity: _____

Cooling water temperature: _____

Stator temperature: _____

Other data as applicable: _____

- Generator ~~hydrogen~~**cooling gas** pressure at time of test (if applicable) _____
~~Date that data shown in last verification column in table above was taken~~ _____

Remarks:

- Note: If the ~~verification value~~**staged test/operational data** did not reach ~~the thermal~~ capability curve (D-curve), describe the ~~reason~~**limiting factor**.

Testing Remarks:

Summary report:	
Litera Compare for Word 11.3.1.3 Document comparison done on 4/20/2023 6:41:52 PM	
Style name: NERC Standards	
Intelligent Table Comparison: Active	
Original filename: MOD-025-2.docx	
Modified filename: MOD-025-3 Draft 2.0.docx	
Changes:	
Add	480
Delete	389
Move From	22
Move To	22
Table Insert	8
Table Delete	2
Table moves to	0
Table moves from	0
Embedded Graphics (Visio, ChemDraw, Images etc.)	12
Embedded Excel	0
Format changes	0
Total Changes:	935