

Technical Rationale for Reliability Standard PRC-002-5

March 2024

PRC-002-5 – Disturbance Monitoring and Reporting Requirements

Rationale for Applicability Section

Because the Reliability Coordinator has the best wide-area view of the Bulk Electric System (BES), the Reliability Coordinator is most suited to be responsible for determining the BES Elements for which dynamic Disturbance recording (DDR) data is required. The Transmission Owners and Generator Owners will have the responsibility for ensuring that adequate data is available for those BES Elements selected. BES buses where sequence of events recording (SER) and fault recording (FR) data is required are best selected by Transmission Owners because they have the required tools, information, and working knowledge of their Systems to determine those buses. The Transmission Owners and Generator Owners that own BES Elements on those BES buses will have the responsibility for ensuring that adequate data is available.

The recent disturbance reports (e.g., Blue Cut Fire, Canyon 2 Fire, Odessa disturbances) have identified a need for disturbance monitoring for inverter-based resources (IBRs) to aid with event analysis, performance monitoring, and disturbance-based IBR generating facility model validation. The purpose of Reliability Standard PRC-002 is to capture event data to understand large scale system disturbances occurring on the BES. Even with changing resource mix, the Reliability Standard PRC-002 serves the purpose. Introducing IBR monitoring requirements to Reliability Standard PRC-002 may create unintended consequences to purpose of Reliability Standard PRC-002 and may lead to industry confusion. Hence, to address needs identified in the Standard Authorization Request (SAR) submitted by the Inverter-Based Resource Performance Task Force (IRPTF), a new standard for monitoring requirements for IBRs is created instead of revising the Reliability Standard PRC-002. To avoid any overlap between the Reliability Standards PRC-002 and PRC-028, BES Elements within inverter-based portions of generating plants/Facilities meeting the criteria set by Inclusion I2, part (b) or Inclusion I4 of the BES definition. Example in Figure 1 is provided to clarify applicability of Reliability Standards PRC-002 and PRC-028. The IBR generating facility in this example meets the criteria in inclusion I2 of the BES definition. The BES bus in substation Scott is the identified BES bus per methodology in Attachment 1 of the Reliability Standard PRC-002. The SER and FR data requirements for BES Elements associated with the identified BES bus are per the Reliability Standard PRC-002 except for Elements associated with the IBR generating facility, i.e., circuit breaker 3. The SER, FR, and DDR data requirements for the IBR generating facility are specified in the Reliability Standard PRC-028.

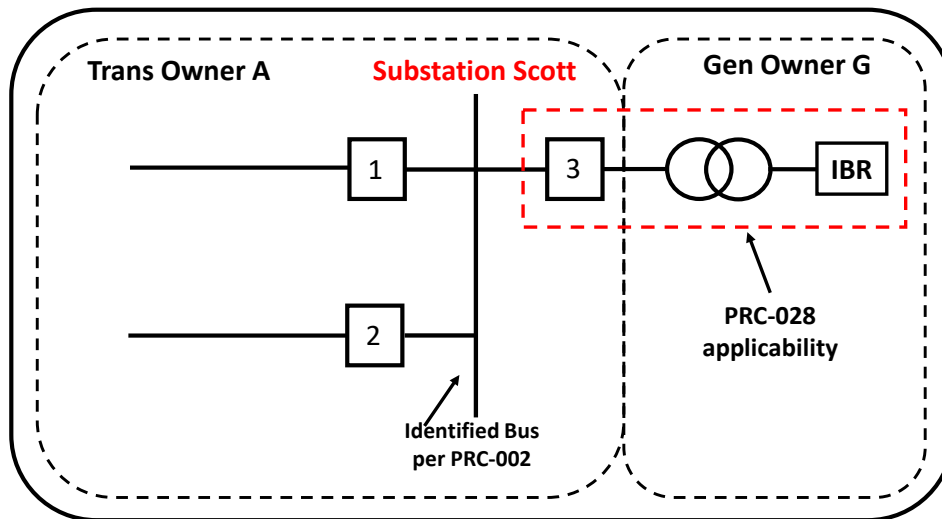

Figure 1: Example to Clarify Applicability of PRC-002 Versus PRC-028

Rationale for Requirement R1

Analysis and reconstruction of BES events requires SER and FR data from key BES buses. Attachment 1 provides a uniform methodology to identify those BES buses. Repeated testing of the Attachment 1 methodology has demonstrated the proper distribution of SER and FR data collection. Review of actual BES short circuit data received from the industry in response to the Disturbance Monitoring Standard Drafting Team (DMSDT) data request (June 5, 2013 through July 5, 2013) illuminated a strong correlation between the available short circuit MVA at a Transmission bus and its relative size and importance to the BES based on (i) its voltage level, (ii) the number of Transmission Lines and other BES Elements connected to the BES bus, and (iii) the number and size of generating units connected to the bus. BES buses with a large short circuit MVA level are BES Elements that have a significant effect on System reliability and performance. Conversely, BES buses with very low short circuit MVA levels seldom cause wide-area or cascading System events, so SER and FR data from those BES Elements are not as significant. After analyzing and reviewing the collected data submittals from across the continent, the threshold MVA values were chosen to provide sufficient data for event analysis using engineering and operational judgment.

Concerns have existed that the defined methodology for bus selection will overly concentrate data to selected BES buses. For the purpose of PRC-002-5, there are a minimum number of BES buses for which SER and FR data is required based on the short circuit level. With these concepts and the objective being sufficient recording coverage for event analysis, the DMSDT developed the procedure in Attachment 1 that utilizes the maximum available calculated three-phase short circuit MVA. This methodology ensures comparable and sufficient coverage for SER and FR data regardless of variations in the size and System topology of Transmission Owners across all Interconnections. Additionally, this methodology provides a degree of flexibility for the use of judgment in the selection process to ensure sufficient distribution.

BES buses where SER and FR data is required are best selected by Transmission Owners because they have the required tools, information, and working knowledge of their Systems to determine those buses.

Each Transmission Owner must re-evaluate the list of BES buses at least every five calendar years to address System changes since the previous evaluation. Changes to the BES do not mandate immediate inclusion of BES buses into the currently enforced list, but the list of BES buses will be re-evaluated at least every five calendar years to address System changes since the previous evaluation.

Since there may be multiple owners of equipment that comprise a BES bus, the notification required in R1 is necessary to ensure all owners are notified.

A 90-calendar day notification deadline provides adequate time for the Transmission Owner to make the appropriate determination and notification.

Sequence of events and fault recording for the analysis, reconstruction, and reporting of System Disturbances is important. However, SER and FR data is not required at every BES bus on the BES to conduct adequate or thorough analysis of a Disturbance. As major tools of event analysis, the time synchronized time stamp for a breaker change of state and the recorded waveforms of voltage and current for individual circuits allows the precise reconstruction of events of both localized and wide-area Disturbances.

More quality information is always better than less when performing event analysis. However, 100 percent coverage of all BES Elements is not practical nor required for effective analysis of wide-area Disturbances. Therefore, selectivity of required BES buses to monitor is important for the following reasons:

1. Identify key BES buses with breakers where crucial information is available when required.
2. Avoid excessive overlap of coverage.
3. Avoid gaps in critical coverage.
4. Provide coverage of BES Elements that could propagate a Disturbance.
5. Avoid mandates to cover BES Elements that are more likely to be a casualty of a Disturbance rather than a cause.
6. Establish selection criteria to provide effective coverage in different regions of the continent.

The major characteristics available to determine the selection process are:

1. System voltage level;
2. The number of Transmission Lines into a substation or switchyard;
3. The number and size of connected generating units;
4. The available short circuit levels.

5. Although it is straightforward to establish criteria for the application of identified BES buses, analysis was required to establish a sound technical basis to fulfill the required objectives.

To answer these questions and establish criteria for BES buses of SER and FR, the DMSDT established a sub-team referred to as the Monitored Value Analysis Team (MVA Team). The MVA Team collected information from a wide variety of Transmission Systems throughout the continent to analyze Transmission buses by the characteristics previously identified for the selection process.

The MVA Team learned that the development of criteria is not possible for adequate SER and FR coverage, based solely upon simple, bright line characteristics, such as the number of lines into a substation or switchyard at a particular voltage level or at a set level of short circuit current. To provide the appropriate coverage, a relatively simple but effective Methodology for Selecting Buses for Capturing Sequence of Events Recording (SER) and Fault Recording (FR) Data was developed. This Procedure, included as Attachment 1, assists entities in fulfilling Requirement R1 of the standard.

The Methodology for Selecting Buses for Capturing Sequence of Events Recording (SER) and Fault Recording (FR) Data is weighted to buses with higher short circuit levels. This is chosen for the following reasons:

1. The method is voltage level independent.
2. It is likely to select buses near large generation centers.
3. It is likely to select buses where delayed clearing can cause Cascading.
4. Selected buses directly correlate to the Universal Power Transfer equation: Lower Impedance – increased power flows – greater System impact.

To perform the calculations of Attachment 1, the following information below is required and the following steps (provided in summary form) are required for Systems with more than 11 BES buses with three phase short circuit levels above 1,500 MVA.

1. Total number of BES buses in the Transmission System under evaluation.
 - a. Only tangible substation or switchyard buses are included.
 - b. Pseudo buses created for analysis purposes in System models are excluded.
2. Determine the three-phase short circuit MVA for each BES bus.
3. Exclude BES buses from the list with short circuit levels below 1,500 MVA.
4. Determine the median short circuit for the top 11 BES buses on the list (position number 6).
5. Multiply median short circuit level by 20 percent.
6. Reduce the list of BES buses to those with short circuit levels higher than the greater of 1500 MVA or 20 percent of the median MVA level determined in Step 5.

7. Apply SER and FR at BES buses with short circuit levels in the top 10 percent of the list (from 6).
8. Apply SER and FR at BES buses at an additional 10 percent of the list using engineering judgment, and allowing flexibility to factor in the following considerations:
 - Electrically distant BES buses or electrically distant from other DME devices
 - Voltage sensitive areas
 - Cohesive load and generation zones
 - BES buses with a relatively high number of incident Transmission circuits
 - BES buses with reactive power devices
 - Major facilities interconnecting outside the Transmission Owner's area.

Per the methodology in Attachment 1, FR/SER data is required at the BES bus with highest maximum available three phase short circuit MVA when the list in Step 6 has one or more, but less than or equal to 11, BES buses. Requirement R1, Part 1.3 requires re-evaluation of BES buses at least once every five calendar years in accordance with Part 1.1. Depending on results of this re-evaluation, the location at which SER/FR data is required could change due to a minor change in the three-phase short circuit MVA. This is especially true for small Transmission Owners which are only required to have SER/FR data for one (1) BES bus per allowance based on the methodology in Attachment 1. To help avoid cost and compliance burden, a criterion that constitutes a change in fault current levels, which would require changing SER and FR data recording locations, is included in Attachment 1. During the re-evaluation per Requirement R1, Part 1.3, if the three-phase short circuit MVA of the newly identified BES bus is within 15% of the three-phase short circuit MVA of the currently applicable BES bus with SER and FR data, then it is not necessary to change the applicable BES bus.

As an example, during an initial evaluation, three BES buses A, B, and C are identified in Step 6. The maximum three-phase short circuit MVA of buses A, B, and C is 1600 MVA, 1500 MVA, and 1550 MVA respectively. The SER/FR data is required at Bus A. During a first re-evaluation, the same three buses are identified in Step 6. The maximum three-phase short circuit MVA of buses A, B, and C is 1550 MVA, 1675 MVA, and 1600 MVA respectively. The bus B is the one with highest maximum three-phase short circuit MVA now. The three-phase short circuit MVA of bus B is within 15% of the three-phase short circuit MVA of bus A (1675 is only 8% above 1550) where SER/FR data is being recorded. Hence, it is not necessary to change SER/FR data recording location to bus B. During a next re-evaluation, the same three buses are identified again in Step 6. The maximum three-phase short circuit MVA of buses A, B, and C is 1500 MVA, 1750 MVA, and 1650 MVA respectively. The three-phase short circuit MVA of bus B is greater than 15% of three-phase short circuit MVA of bus A (1750 is 16.7% above the 1500) where SER/FR data is being recorded. Hence, it is necessary to change SER/FR data recording location to bus B.

For event analysis purposes, more valuable information is attained about generators and their response to System events pre- and post-contingency through DDR data versus SER or FR records. SER data of the opening of the primary generator output interrupting devices (e.g. synchronizing breaker) may not reliably indicate the actual time that a generator tripped; for instance, when it trips on reverse

power after loss of its prime mover (e.g. combustion or steam turbine). As a result, this standard requires DDR data. Refer to Rationale for Requirement R5 for more details.

Since there may be multiple owners of equipment that comprise a BES bus, the notification required in Requirement R1, Part 1.2 is necessary to ensure all owners of “directly connected” BES Elements are notified. For the purposes of this standard, “directly connected” BES elements are BES elements connected at the same voltage level within the same physical location sharing a common ground grid with the BES bus identified under Attachment 1. Transformers that have a low-side operating voltage of less than 100kV are excluded. The following examples are provided to clarify notification requirement.

The straight and ring bus configurations shown in Figures 2 and 3 respectively, are the simplest BES bus configurations. Transmission Owner A owns the identified BES bus, including physical bus(es) as well as all three circuit breakers. Circuit breakers 1, 2, and 3 are BES Elements that are directly connected to the identified BES bus. The Transmission Owner A records SER/FR data for all three circuit breakers. In these cases, Transmission Owner A is not required to send notification to Transmission Owner B.

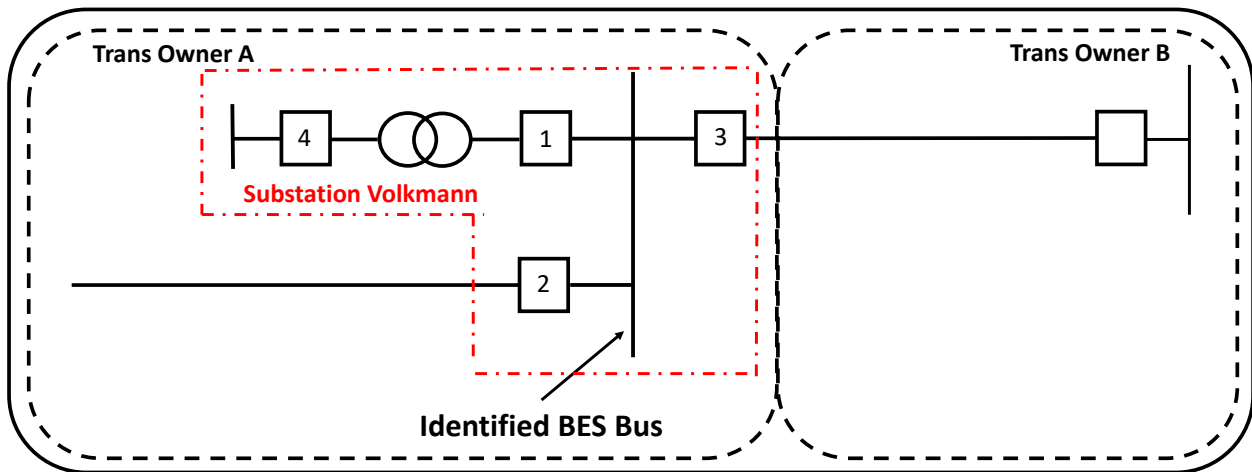

Figure 2: Straight Bus Configuration – Single Owner

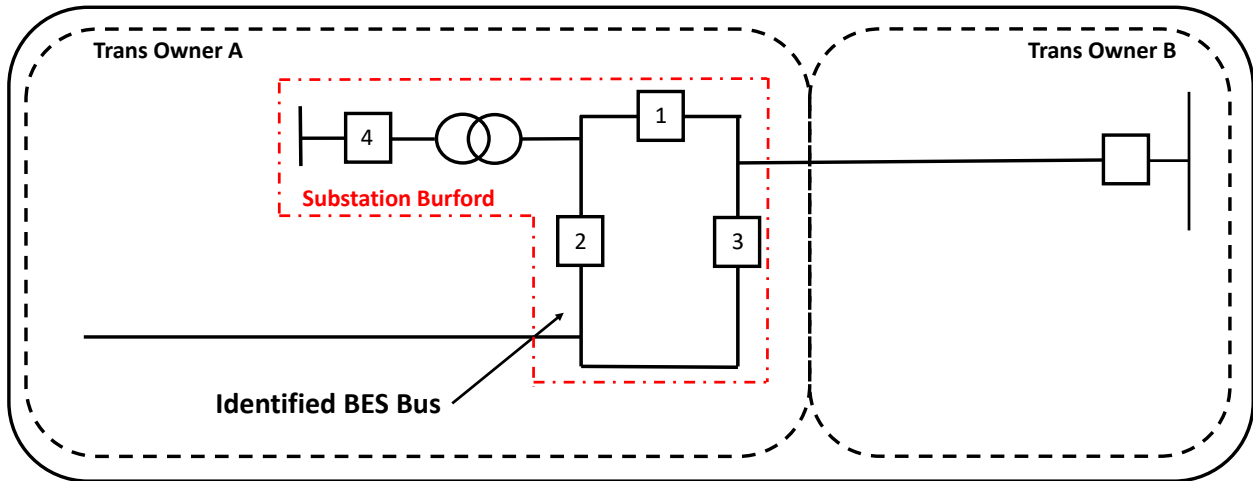

Figure 3: Ring Bus Configuration – Single Owner

Figures 4 and 5 show straight and ring bus configurations respectively, but with equipment that comprise a BES bus owned by multiple owners. Circuit breakers 1, 2, and 3 are BES Elements that are directly connected to the identified BES bus. The Transmission Owner A identifies a BES bus for which SER and FR data is required per Requirement R1, Part 1.1 and methodology included in Attachment 1. Transmission Owner A owns a portion of the physical bus(es) as well as circuit breakers 1 and 2. Transmission Owner B owns the remaining portion of the physical bus(es) and directly connected circuit breaker 3. All equipment (physical bus(es) and circuit breakers) that comprise the BES bus is located within the same physical space, i.e., substation Kealy, regardless of ownership.

In these cases, Transmission Owner A is responsible for SER and FR data for circuit breakers 1 and 2. The Transmission Owner B is owner of circuit breaker 3. Per Requirement R1, Part 1.2, if Transmission Owner A does not record SER and FR data for circuit breaker 3, then Transmission Owner B must be notified that SER/FR data is required for circuit breaker 3.

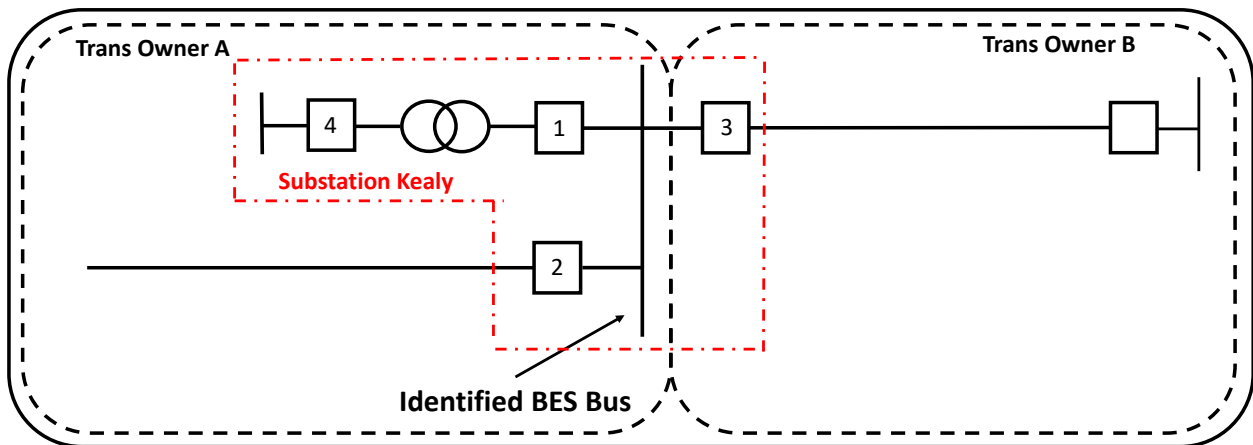

Figure 4: Straight Bus Configuration – Multiple Owners

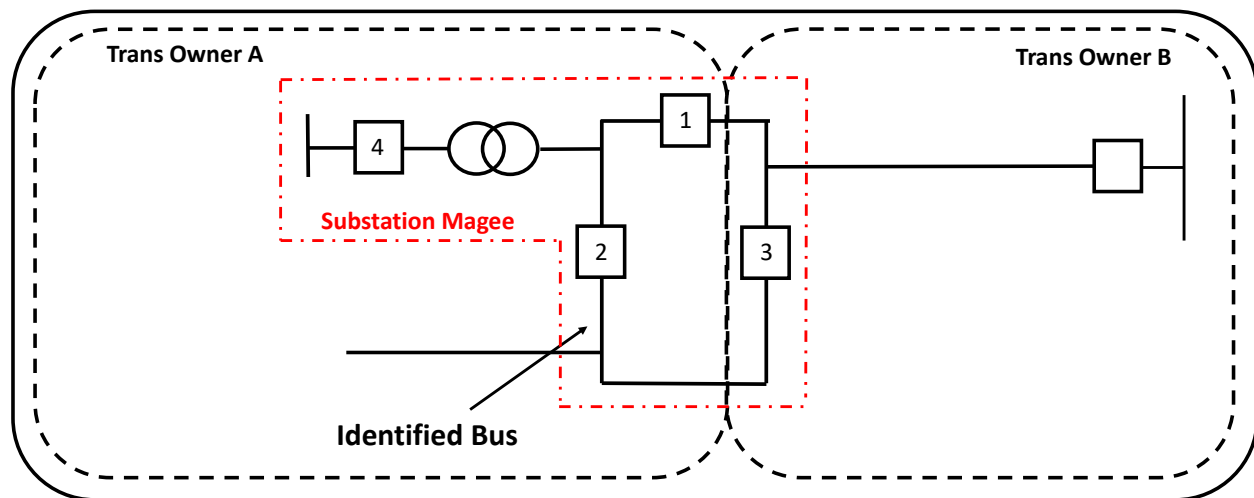

Figure 5: Ring Bus Configuration – Multiple Owners

For examples in Figures 4 and 5, if Transmission Owner A records SER/FR data for circuit breaker 3 (even though owned by Transmission Owner B), then Transmission Owner A is not required to notify Transmission Owner B.

Figure 6 shows an example with a generator interconnection. Circuit breakers 1, 2, and 3 are BES Elements that are directly connected to the identified BES bus. Transmission Owner A identifies a BES bus for which SER and FR data is required per Requirement R1, Part 1.1. Transmission Owner A owns the physical bus as well as directly connected circuit breakers 1 and 2. Generator Owner G owns directly connected circuit breaker 3. All equipment (physical bus(es) and circuit breakers) that comprise a BES bus is located within the same physical space, i.e., substation Burkart, regardless of ownership.

Transmission Owner A is responsible for SER and FR data for circuit breakers 1 and 2. The Generator Owner G is owner of circuit breaker 3. Per Requirement R1, Part 1.2, if Transmission Owner A does not record SER data for circuit breaker 3, then Generator Owner G must be notified that SER data is required for circuit breaker 3. Per the criteria in Requirement R3, Part 3.2.1, FR data is not required for circuit breaker 3.

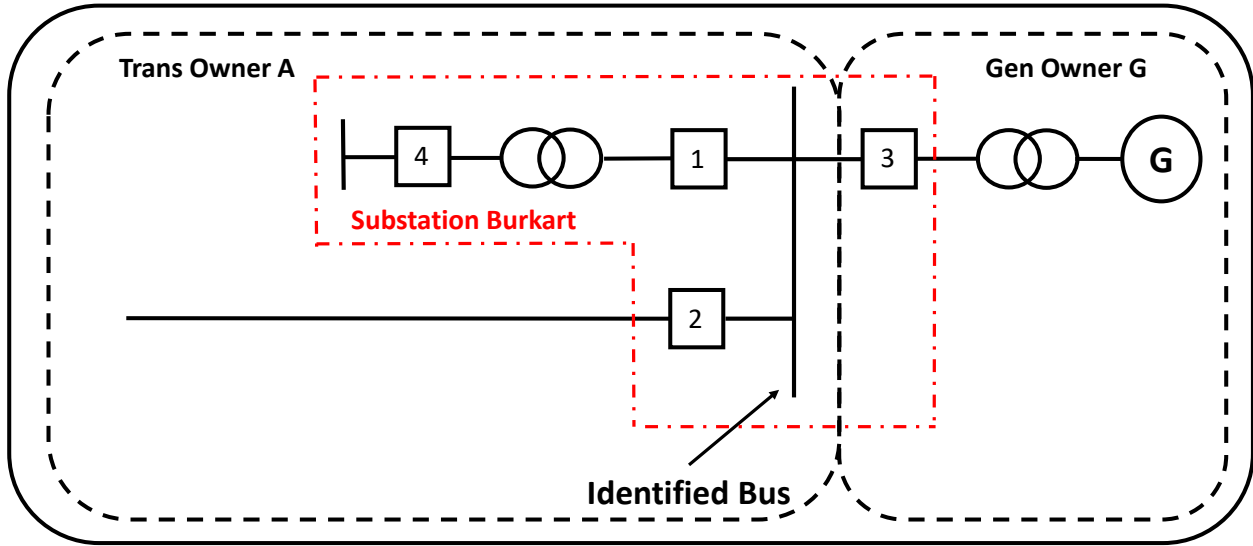

Figure 6: Generator Interconnection to Straight Bus

For a generator interconnection to a ring bus, as shown in Figure 7, Transmission Owner A is responsible for SER data for circuit breakers 1, 2, and 3. The Transmission Owner A is required to record FR data for contributions from the transmission line (circuit breakers 2 and 3) and transformer (circuit breakers 1 and 2). However, per the criteria in Requirement R3, Part 3.2.1, FR data is not required for contribution from the generator.

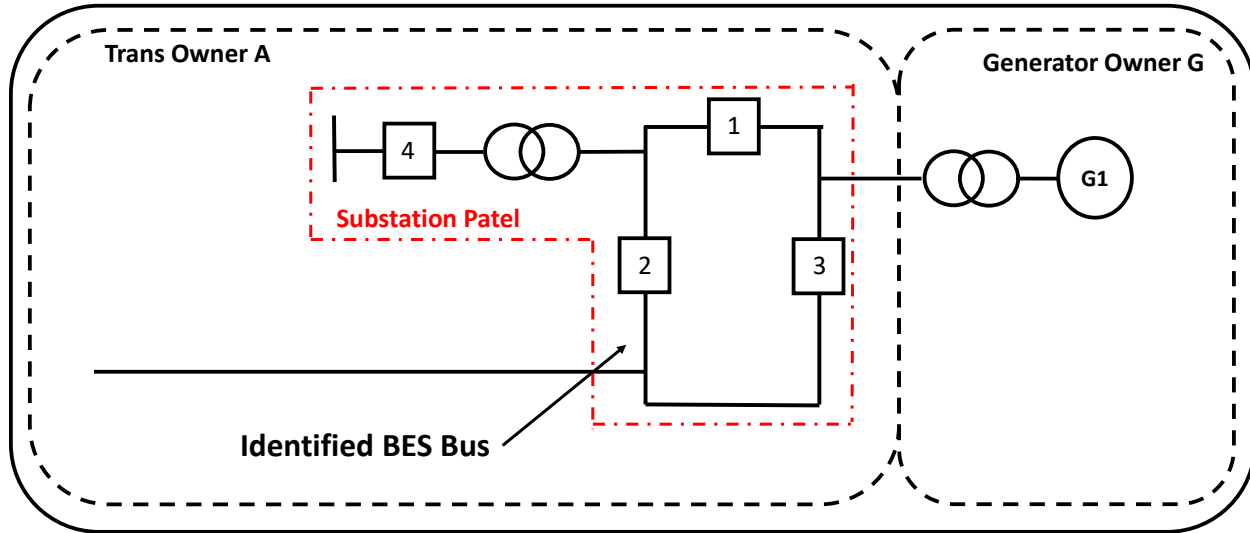

Figure 7: Generator Interconnection to Ring Bus

Figure 8 shows another example of a generator interconnection where generating units/a plant is connected via a transmission line to the identified BES bus for which SER and FR data is required. Circuit breakers 1, 2, and 3 are BES Elements that are directly connected to the identified BES bus. Transmission Owner A owns the physical bus as well as circuit breakers 1 and 2. Generator Owner G owns directly connected circuit breaker 3 and a short transmission line to the generating plant. All equipment (physical

bus(es) and circuit breakers) that comprise a BES bus is located within the same physical space, i.e., substation Key, regardless of ownership.

Transmission Owner A is responsible for SER and FR data for circuit breakers 1 and 2. The Generator Owner G is owner of circuit breaker 3. Per Requirement R1, Part 1.2, if Transmission Owner A does not record SER data for circuit breaker 3, then Generator Owner G must be notified that SER data is required for circuit breaker 3. Per rationale for Requirement R3, FR data is not required for circuit breaker 3 because the transmission line (connecting the generating plant to the Transmission System) is used to exclusively export energy from the generating plant.

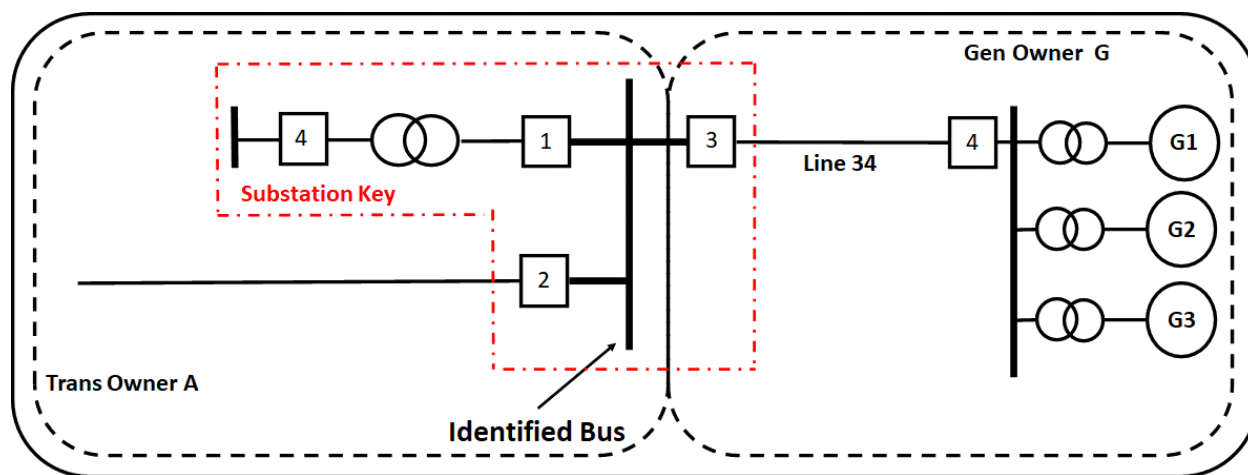

Figure 8: Generator Interconnection via Line 34

Figure 9 shows an example of a generator interconnection via multiple lines that creates a transmission loop. Circuit breakers 1, 2, 3, and 5 are BES Elements that are directly connected to the identified BES bus. Transmission Owner A owns the physical bus as well as circuit breakers 1 and 2. Generator Owner G owns directly connected circuit breakers 3 and 5 and both transmission lines to the generating plant. All equipment (physical bus(es) and circuit breakers) that comprise a BES bus is located within the same physical space, i.e., substation Milan, regardless of ownership.

Transmission Owner A is responsible for SER and FR data for circuit breakers 1 and 2. The loop is created by Line 36 and Line 57. These lines are exclusively used to export power from the generating plant to the transmission system. The FR data is not required for these lines, however, SER data is required on circuit breakers 3 and 5. Per Requirement R1, Part 1.2, if Transmission Owner A does not record SER data for circuit breakers 3 and 5, then Generator Owner G must be notified that SER data is required for circuit breakers 3 and 5.

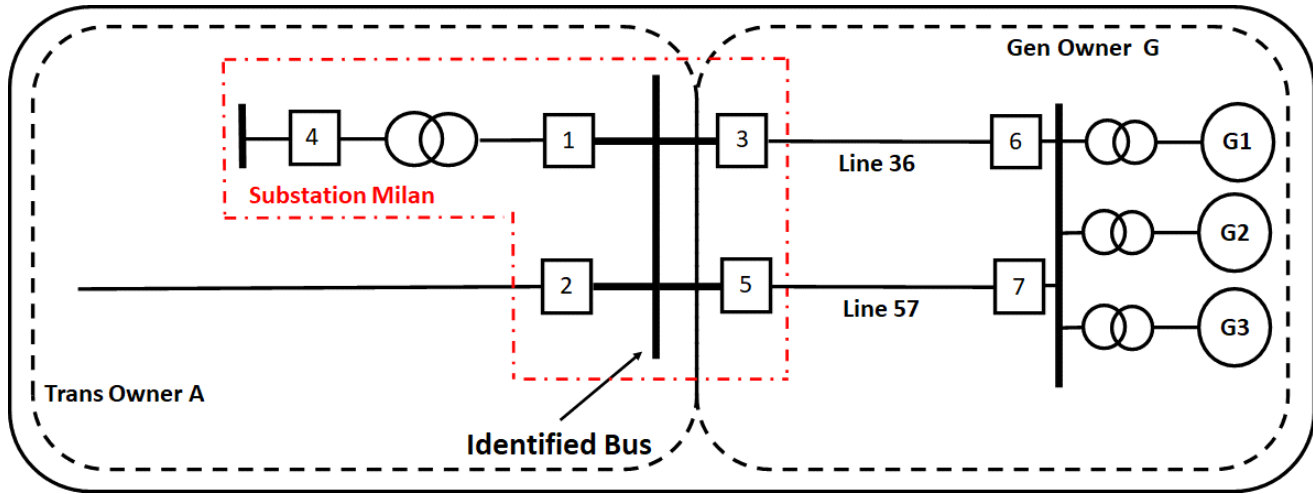

Figure 9: Generator Interconnection via Multiple Lines

The following is an example of a notification provided by Transmission Owner A to Transmission Owner B:

Notification details:

FROM	Transmission Owner A
TO	Transmission Owner B
CC	
BCC	NA
SUBJECT	PRC-002 R1.2 2027 Notification Transmission Owner B

Greetings,

In accordance with NERC Standard PRC-002-5, Requirement R1.1, Transmission Owner A has identified its BES buses for which sequence of events recording (SER) and fault recording (FR) data is required, using the methodology in Attachment 1.

Per Requirement R1.2, you are being notified that the below BES Elements have been determined to be directly connected to one of the buses identified in R1.1 and owned by Transmission Owner B. Transmission Owner A does not have SER and/or FR data on the BES Elements listed below, and thus Transmission Owner B is required to have SER and/or FR data on the following BES Elements:

Transmission Owner A Bus (R1.1)	Directly connected BES Element owned by Transmission Owner B	BES Element Type	Data Required
KEALY 500 kV	Breakers: 3	Breaker	SER
MAGEE 500 kV	Breakers: 3	Breaker	SER
MILAN 500 kV	Lines: 36, 57	Line	FR
MILAN 500 kV	Breakers: 3, 5	Breaker	SER

BURKART 500kV	Breakers: 3	Breaker	SER
EXAMPLE 500kV	Transformer	Transformer	FR

If you have any questions about this notification, analysis or otherwise, please email Transmission Owner A.

Thank you,
Transmission Owner A

The re-evaluation interval of five years was chosen based on the experience of the DMSDT to address changing System configurations while creating balance in the frequency of re-evaluations.

Rationale for Requirement R2

The intent is to capture SER data for the status (open/close) of the circuit breakers that can interrupt the current flow through each BES Element directly connected to a BES bus. Change of state of circuit breaker position and time stamped according to Requirement R10 to a time synchronized clock, provides the basis for assembling the detailed sequence of events timeline of a power System Disturbance. Other status monitoring nomenclature can be used for devices other than circuit breakers.

Analyses of wide-area Disturbances often begin by evaluation of SERs to help determine the initiating event(s) and follow the Disturbance propagation. Recording of breaker operations help determine the interruption of line flows while generator loading is best determined by DDR data, since generator loading can be essentially zero regardless of breaker position.

However, generator breakers directly connected to an identified BES bus are required to have SER data captured. It is important in event analysis to know when a BES bus is cleared regardless of a generator’s loading.

Generator Owners are included in this requirement because a Generator Owner may, in some instances, own breakers directly connected to the Transmission Owner’s BES bus.

Examples in Figures 10, 11, and 12 show BES Elements directly connected to an identified BES bus that are required to have SER data captured.

Rationale for Requirement R3

The required electrical quantities may either be directly measured or determinable if sufficient FR data is captured (e.g. residual or neutral current if the phase currents are directly measured). In order to cover all possible fault types, all BES bus phase-to-neutral voltages are required to be determinable for each BES bus identified in Requirement R1. BES bus voltage data is adequate for System Disturbance analysis. Phase current and residual current are required to distinguish between phase faults and ground faults. It also facilitates determination of the fault location and cause of relay operation. For transformers (Part 3.2.1), the data may be from either the high-side or the low-side of the transformer. Generator step-up transformers (GSUs) and leads that connect the GSU transformer(s) to the Transmission System that are

used exclusively to export energy directly from a BES generating unit or generating plant are excluded from Requirement R3 because the fault current contribution from a generator to a fault on the Transmission System will be captured by FR data on the Transmission System, and Transmission System FR will capture faults on the generator interconnection.

The BES buses for which FR data is required are determined based on the methodology described in Attachment 1 of the standard. The BES Elements directly connected to those BES buses for which FR data is required include:

- Transformers with a low-side operating voltage of 100kV or above
- Transmission Lines

Only those BES Elements that are identified as BES as defined in the latest in effect NERC definition are to be monitored. For example, radial lines or transformers with low-side voltage less than 100kV are not included.

FR data must be determinable from each terminal of a BES Element directly connected to applicable BES buses.

Generator step-up transformers (GSU) are excluded from the above based on the following:

- Current contribution from a generator in case of fault on the Transmission System will be captured by FR data on the Transmission System.
- For faults on the interconnection to generating facilities, it is sufficient to have fault current data from the Transmission station end of the interconnection. Current contribution from a generator can be readily calculated if needed.

Examples in Figures 10, 11, and 12 show BES Elements directly connected to an identified BES bus that are required to have FR data captured.

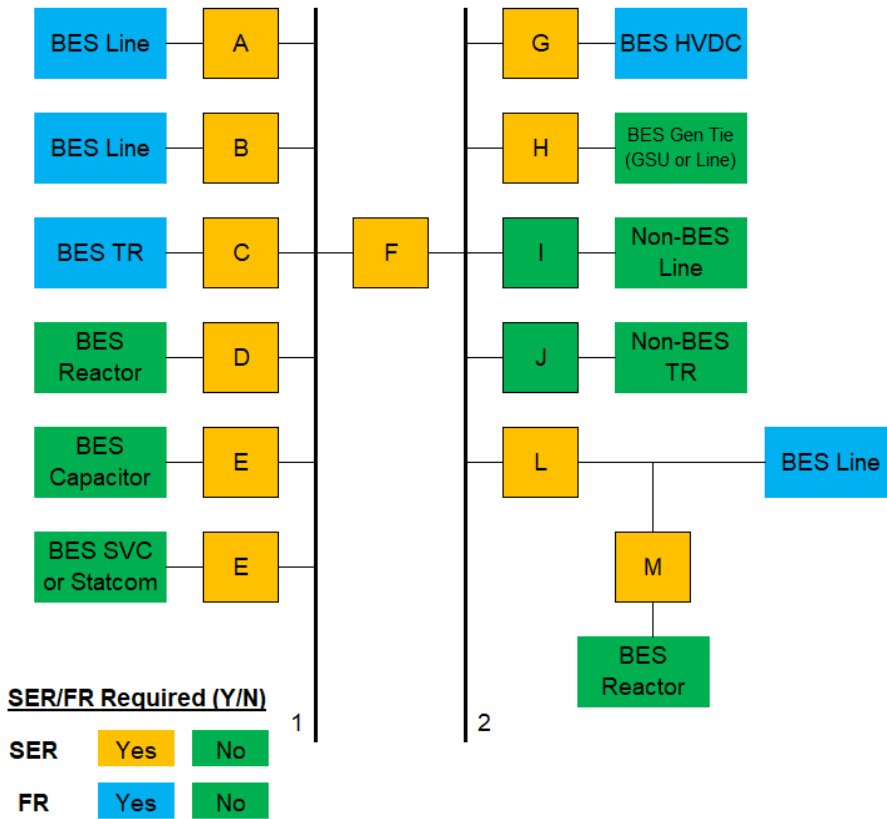

Figure 10: Straight BES Buses

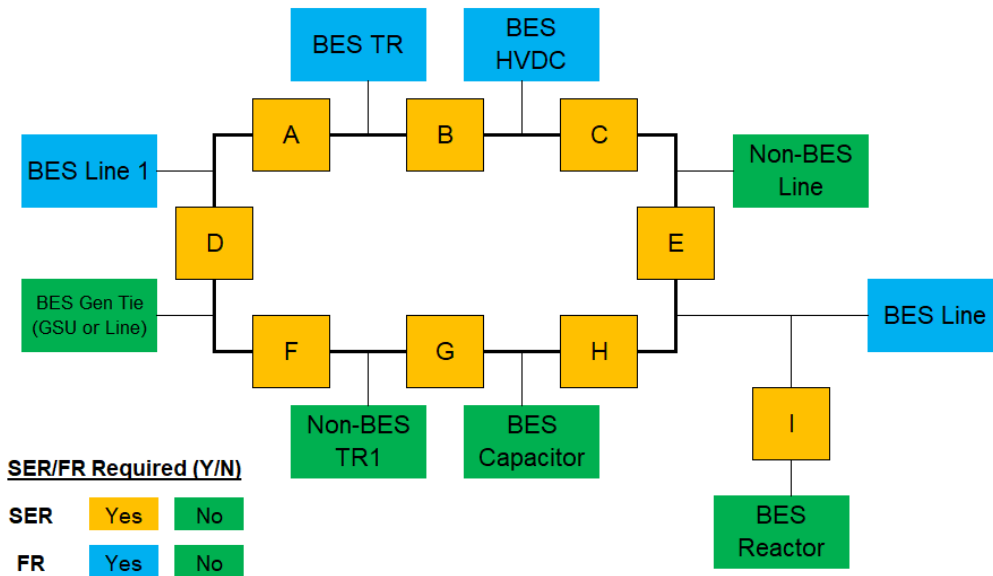

Figure 11: Ring BES Bus

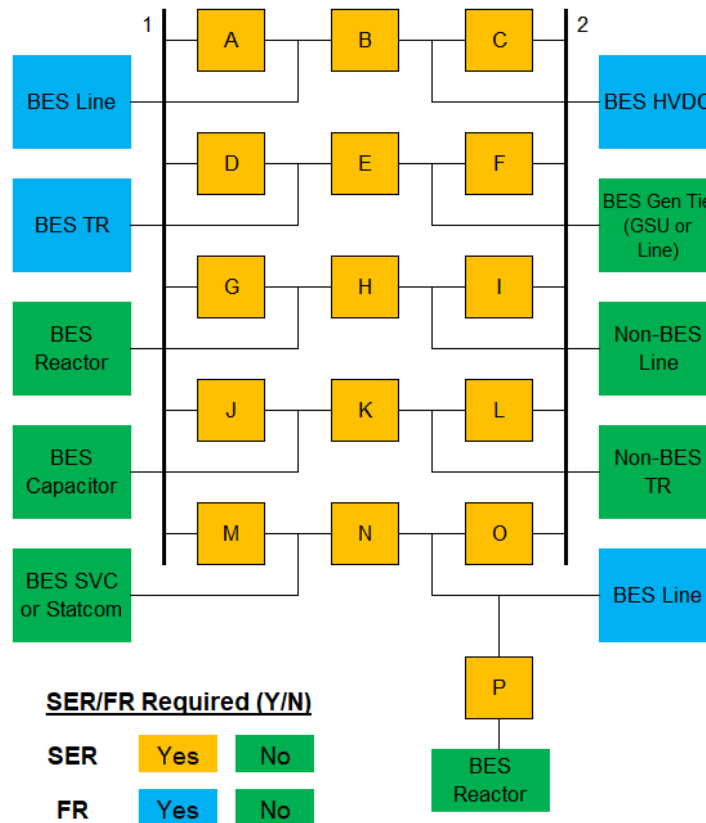

Figure 12: Breaker and Half BES Bus

The DMSDT, after consulting with NERC’s Event Analysis group, determined that DDR data from selected generator locations was more important for event analysis than FR data.

Recording of Electrical Quantities

For effective fault analysis it is necessary to know values of all phase and neutral currents and all phase-to-neutral voltages. Based on such FR data, it is possible to determine all fault types. FR data also augments SERs in evaluating circuit breaker operation.

Current Recordings

The required electrical quantities are normally directly measured. Certain quantities can be derived if sufficient data is measured, for example, residual or neutral currents. Since a Transmission System is generally well balanced, with phase currents having essentially similar magnitudes and phase angle differences of 120° , during normal conditions there is negligible neutral (residual) current. In case of a ground fault, the resulting phase current imbalance produces residual current that can be either measured or calculated.

Neutral current, also known as ground or residual current I_r , is calculated as a sum of vectors of three

phase currents:

$$I_r = 3 \cdot I_0 = I_A + I_B + I_C$$

I_0 - Zero-sequence current

I_A, I_B, I_C - Phase current (vectors)

Another example of how required electrical quantities can be derived is based on Kirchhoff's Law. Fault currents for one of the BES Elements connected to a particular BES bus can be derived as a vectorial sum of fault currents recorded at the other BES Elements connected to that BES bus.

Voltage Recordings

Voltages are to be recorded or accurately determined at applicable BES buses

Rationale for Requirement R4

Time stamped pre- and post-trigger fault data aid in the analysis of power System operations and determination if operations were as intended. System faults generally persist for a short time period, thus a 30-cycle total minimum record length is adequate. Multiple records allow for legacy microprocessor relays which, when time-synchronized, are capable of providing adequate fault data but not capable of providing fault data in a single record with 30- contiguous cycles total.

A minimum recording rate of 16 samples per cycle (960 Hz) is required to get sufficient point on wave data for recreating accurate fault conditions.

Pre- and post-trigger fault data along with the SER breaker data, all time stamped to a common clock at millisecond accuracy, aid in the analysis of Protection System operations after a fault to determine if a Protection System operated as designed. Generally speaking, BES faults persist for a very short time period, approximately 1 to 30 cycles, thus a 30-cycle record length provides adequate data. Multiple records allow for legacy microprocessor relays which, when time synchronized to a common clock, are capable of providing adequate fault data but not capable of providing fault data in a single record with 30-contiguous cycles total.

A minimum recording rate of 16 samples per cycle is required to get accurate waveforms and to get 1 millisecond resolution for any digital input which may be used for FR.

FR triggers can be set so that when the monitored value on the recording device goes above or below the trigger value, data is recorded. Requirement R4, sub-Part 4.3.1 specifies a neutral (residual) overcurrent trigger for ground faults. Requirement R4, sub-Part 4.3.2 specifies a phase undervoltage or overcurrent trigger for phase-to-phase faults.

Rationale for Requirement R5

DDR is used for capturing the BES transient and post-transient response following Disturbances, and the data is used for event analysis and validating System performance. DDR plays a critical role in wide-area Disturbance analysis, and Requirement R5 ensures there is adequate wide-area coverage of DDR data for

specific BES Elements to facilitate accurate and efficient event analysis. The Reliability Coordinator has the best wide-area view of the System and needs to ensure that there are sufficient BES Elements identified for DDR data capture. The identification of BES Elements requiring DDR data, as per Requirement R5, is based upon industry experience with wide-area Disturbance analysis and the need for adequate data to facilitate event analysis. Ensuring data is captured for these BES Elements will significantly improve the accuracy of analysis and understanding of why an event occurred, not simply what occurred.

From its experience with changes to the Bulk Electric System that would affect DDR, the DMSDT decided that the five calendar year re-evaluation of the list is a reasonable interval for this review. Changes to the BES do not mandate immediate inclusion of BES Elements into the in force list, but the list of BES Elements will be re-evaluated at least every five calendar years to address System changes since the previous evaluation. However, this standard does not preclude the Reliability Coordinator from performing this re-evaluation more frequently to capture updated BES Elements.

The Reliability Coordinator must notify all owners of the selected BES Elements that DDR data is required for this standard. The Reliability Coordinator is only required to share the list of selected BES Elements that each Transmission Owner and Generator Owner respectively owns, not the entire list. This communication of selected BES Elements is required to ensure that the owners of the respective BES Elements are aware of their responsibilities under this standard.

Implementation of the monitoring equipment is the responsibility of the respective Transmission Owners and Generator Owners, the timeline for installing this capability is outlined in the Implementation Plan, and starts from notification of the list from the Reliability Coordinator. Data for each BES Element, as defined by the Reliability Coordinator, must be provided; however, this data can be either directly measured or accurately calculated. With the exception of HVDC circuits, DDR data is only required for one end or terminal of the BES Elements selected. For example, DDR data must be provided for at least one terminal of a Transmission Line or generator step-up (GSU) transformer, but not both terminals. For an interconnection between two Reliability Coordinators, each Reliability Coordinator will consider this interconnection independently, and are expected to work cooperatively to determine how to monitor the BES Elements that require DDR data. For an interconnection between two TO's, or a TO and a GO, the Reliability Coordinator will determine which entity will provide the data. The Reliability Coordinator will notify the owners that their BES Elements require DDR data.

Refer to the Guidelines and Technical Basis Section for more detail on the rationale and technical reasoning for each identified BES Element in Requirement R5, Part 5.1; monitoring these BES Elements with DDR will facilitate thorough and informative event analysis of wide-area Disturbances on the BES. Part 5.2 is included to ensure wide-area coverage across all Reliability Coordinators. It is intended that each Reliability Coordinator will have DDR data for one BES Element and at least one additional BES Element per 3,000 MW of its historical simultaneous peak System Demand.

DDR data is used for wide-area Disturbance monitoring to determine the System's electromechanical transient and post-transient response and validate System model performance. DDR is typically located based on strategic studies which include angular, frequency, voltage, and

oscillation stability. However, for adequately monitoring the System’s dynamic response and ensuring sufficient coverage to determine System performance, DDR is required for key BES Elements in addition to a minimum requirement of DDR coverage.

Each Reliability Coordinator is required to identify sufficient DDR data capture for, at a minimum, one BES Element and then one additional BES Element per 3,000 MW of historical simultaneous peak System Demand. This DDR data is included to provide adequate System-wide coverage across an Interconnection. To clarify, if any of the key BES Elements requiring DDR monitoring are within the Reliability Coordinator Area, DDR data capability is required. If a Reliability Coordinator does not meet the requirements of Part 5.1, additional coverage had to be specified.

Loss of large generating resources poses a frequency and angular stability risk for all Interconnections across North America. Data capturing the dynamic response of these machines during a Disturbance helps the analysis of large Disturbances. Having data regarding generator dynamic response to Disturbances greatly improves understanding of **why** an event occurs rather than what occurred. To determine and provide the basis for unit size criteria, the DMSDT acquired specific generating unit data from NERC’s Generating Availability Data System (GADS) program. The data contained generating unit size information for each generating unit in North America which was reported in 2013 to the NERC GADS program. The DMSDT analyzed the spreadsheet data to determine: (i) how many units were above or below selected size thresholds; and (ii) the aggregate sum of the ratings of the units within the boundaries of those thresholds. Statistical information about this data was then produced, i.e. averages, means, and percentages. The DMSDT determined the following basic information about the generating units of interest (current North America fleet, i.e. units reporting in 2013) included in the spreadsheet:

- The number of individual generating units in total included in the spreadsheet.
- The number of individual generating units rated at 20 MW or larger included in the spreadsheet. These units would generally require that their owners be registered as GOs in the NERC CMEP.
- The total number of units within selected size boundaries.
- The aggregate sum of ratings, in MWs, of the units within the boundaries of those thresholds.

The information in the spreadsheet does not provide information by which the plant information location of each unit can be determined, i.e. the DMSDT could not use the information to determine which units were located together at a given generation site or facility.

From this information, the DMSDT was able to reasonably speculate the generating unit size thresholds proposed in Requirement R5, sub-Part 5.1.1 of the standard. Generating resources intended for DDR data recording are those individual units with gross nameplate ratings “greater than or equal to 500 MVA”. The 500 MVA individual unit size threshold was selected because this number roughly accounts for 47 percent of the generating capacity in NERC footprint while only requiring DDR coverage on about 12.5 percent of the generating units. As mentioned, there was no data pertaining to unit location for aggregating plant/facility sizes.

However, Requirement R5, sub-Part 5.1.1 is included to capture larger units located at large generating plants which could pose a stability risk to the System if multiple large units were lost due to electrical or non-electrical contingencies. For generating plants, each individual generator at the plant/facility with a gross nameplate rating greater than or equal to 300 MVA must have DDR where the gross nameplate rating of the plant/facility is greater than or equal to 1,000 MVA. The 300 MVA threshold was chosen based on the DMSDT's judgment and experience. The incremental impact to the number of units requiring monitoring is expected to be relatively low. For combined cycle plants where only one generator has a rating greater than or equal to 300MVA, that is the only generator that would need DDR.

Permanent System Operating Limits (SOLs) are used to operate the System within reliable and secure limits. In particular, SOLs related to angular or voltage stability have a significant impact on BES reliability and performance. Therefore, at least one BES Element of an SOL should be monitored.

The draft standard requires "One or more BES Elements that are part of an Interconnection Reliability Operating Limits (IROLs)." Interconnection Reliability Operating Limits (IROLs) are included because the risk of violating these limits poses a risk to System stability and the potential for cascading outages. IROLs may be defined by a single or multiple monitored BES Element(s) and contingent BES Element(s). The standard does not dictate selection of the contingent and/or monitored BES Elements. Rather, the drafting team believes this determination is best made by the Reliability Coordinator for each IROL considered based on the severity of violating this IROL.

Locations where an undervoltage load shedding (UVLS) program is deployed are prone to voltage instability since they are generally areas of significant Demand. The Reliability Coordinator will identify these areas where a UVLS is in service and identify a useful and effective BES Element to monitor for DDR, such that action of the UVLS or voltage instability on the BES could be captured. For example, a major 500kV or 230kV substation on the EHV System close to the load pocket where the UVLS is deployed would likely be a valuable electrical location for DDR coverage and would aid in post-Disturbance analysis of the load area's response to large System excursions (voltage, frequency, etc.).

Rationale for Requirement R6

DDR is used to measure transient response to System Disturbances during a relatively balanced post-fault condition. Therefore, it is sufficient to provide a phase-to-neutral voltage or positive sequence voltage. The electrical quantities can be determined (calculated, derived, etc.).

Because all of the BES buses within a location are at the same frequency, one frequency measurement is adequate.

The data requirements for PRC-002-5 are based on a System configuration assuming all normally closed circuit breakers on a BES bus are closed.

DDR data shows transient response to System Disturbances after a fault is cleared (post-fault), under a relatively balanced operating condition. Therefore, it is sufficient to provide a single phase-to-neutral

voltage or positive sequence voltage. Recording of all three phases of a circuit is not required, although this may be used to compute and record the positive sequence voltage.

The bus where a voltage measurement is required is based on the list of BES Elements defined by the Reliability Coordinator in Requirement R5. The intent of the standard is not to require a separate voltage measurement of each BES Element where a common bus voltage measurement is available. For example, a breaker-and-a-half or double-bus configuration with a North (or East) Bus and South (or West) Bus, would require both buses to have voltage recording because either can be taken out of service indefinitely with the targeted BES Element remaining in service. This may be accomplished either by recording both bus voltages separately, or by providing a selector switch to connect either of the bus voltage sources to a single recording input of the DDR device. This component of the requirement is therefore included to mitigate the potential of failed frequency, phase angle, real power, and reactive power calculations due to voltage measurements removed from service while sufficient voltage measurement is actually available during these operating conditions.

It must be emphasized that the data requirements for PRC-002-5 are based on a System configuration assuming all normally closed circuit breakers on a bus are closed.

When current recording is required, it should be on the same phase as the voltage recording taken at the location if a single phase-to-neutral voltage is provided. Positive sequence current recording is also acceptable.

For all circuits where current recording is required, Real and Reactive Power will be recorded on a three-phase basis. These recordings may be derived either from phase quantities or from positive sequence quantities.

Rationale for Requirement R7

A crucial part of wide-area Disturbance analysis is understanding the dynamic response of generating resources. Therefore, it is necessary for Generator Owners to have DDR at either the high- or low-side of the generator step-up transformer (GSU) measuring the specified electrical quantities to adequately capture generator response. This standard defines the ‘what’ of DDR, not the ‘how’. Generator Owners may install this capability or, where the Transmission Owners already have suitable DDR data, contract with the Transmission Owner. However, the Generator Owner is still responsible for the provision of this data.

All Guidelines specified for Requirement R6 apply to Requirement R7. Since either the high- or low-side windings of the generator step-up transformer (GSU) may be connected in delta, phase-to-phase voltage recording is an acceptable voltage recording. As was explained in the Guideline for Requirement R6, the BES is operating under a relatively balanced operating condition and, if needed, phase-to-neutral quantities can be derived from phase-to-phase quantities.

Again, it must be emphasized that the data requirements for PRC-002-5 are based on a System configuration assuming all normally closed circuit breakers on a bus are closed.

Rationale for Requirement R8

Large scale System outages generally are an evolving sequence of events that occur over an extended period of time, making DDR data essential for event analysis. Data available pre- and post-contingency helps identify the causes and effects of each event leading to outages. Therefore, continuous recording and storage are necessary to ensure sufficient data is available for the entire event.

Existing DDR data recording across the BES may not record continuously. To accommodate its use for the purposes of this standard, triggered records are acceptable if the equipment was installed prior to the effective date of this standard. The frequency triggers are defined based on the dynamic response associated with each Interconnection. The undervoltage trigger is defined to capture possible delayed undervoltage conditions such as Fault Induced Delayed Voltage Recovery (FIDVR).

Wide-area System outages are generally an evolving sequence of events that occur over an extended period of time, making DDR data essential for event analysis. Pre- and post- contingency data helps identify the causes and effects of each event leading to the outages. This drives a need for continuous recording and storage to ensure sufficient data is available for the entire Disturbance.

Transmission Owners and Generator Owners are required to have continuous DDR for the BES Elements identified in Requirement R6. However, this requirement recognizes that legacy equipment may exist for some BES Elements that do not have continuous data recording capabilities. For equipment that was installed prior to the effective date of the standard, triggered DDR records of three minutes are acceptable using at least one of the trigger types specified in Requirement R8, Part 8.2:

- Off nominal frequency triggers are used to capture high- or low-frequency excursions of significant size based on the Interconnection size and inertia.
- Rate of change of frequency triggers are used to capture major changes in System frequency which could be caused by large changes in generation or load, or possibly changes in System impedance.
- The undervoltage trigger specified in this standard is provided to capture possible sustained undervoltage conditions such as Fault Induced Delayed Voltage Recovery (FIDVR) events. A sustained voltage of 85 percent is outside normal schedule operating voltages and is sufficiently low to capture abnormal voltage conditions on the BES.

Rationale for Requirement R9

An input sampling rate of at least 960 samples per second, which corresponds to 16 samples per cycle on the input side of the DDR equipment, ensures adequate accuracy for calculation of recorded measurements such as complex voltage and frequency.

An output recording rate of electrical quantities of at least 30 times per second refers to the recording and measurement calculation rate of the device. Recorded measurements of at least 30 times per second provide adequate recording speed to monitor the low frequency oscillations typically of interest during power System Disturbances.

DDR data contains the dynamic response of a power System to a Disturbance and is used for

analyzing complex power System events. This recording is typically used to capture short-term and long-term Disturbances, such as a power swing. Since the data of interest is changing over time, DDR data is normally stored in the form of RMS values or phasor values, as opposed to directly sampled data as found in FR data.

The issue of the sampling rate used in a recording instrument is quite important for at least two reasons: the anti-aliasing filter selection and accuracy of signal representation. The anti-aliasing filter selection is associated with the requirement of a sampling rate at least twice the highest frequency of a sampled signal. At the same time, the accuracy of signal representation is also dependent on the selection of the sampling rate. In general, the higher the sampling rate, the better the representation. In the abnormal conditions of interest (e.g. faults or other Disturbances); the input signal may contain frequencies in the range of 0-400 Hz. Hence, the rate of 960 samples per second (16 samples/cycle) is considered an adequate sampling rate that satisfies the input signal requirements.

In general, dynamic events of interest are: inter-area oscillations, local generator oscillations, wind turbine generator torsional modes, HVDC control modes, exciter control modes, and steam turbine torsional modes. Their frequencies range from 0.1-20 Hz. In order to reconstruct these dynamic events, a minimum recording time of 30 times per second is required.

Rationale for Requirement R10

Time synchronization of Disturbance monitoring data is essential for time alignment of large volumes of geographically dispersed records from diverse recording sources. Coordinated Universal Time (UTC) is a recognized time standard that utilizes atomic clocks for generating precision time measurements. All data must be provided in UTC formatted time either with or without the local time offset, expressed as a negative number (the difference between UTC and the local time zone where the measurements are recorded).

Accuracy of time synchronization applies only to the clock used for synchronizing the monitoring equipment. The equipment used to measure the electrical quantities must be time synchronized to ± 2 ms accuracy; however, accuracy of the application of this time stamp and therefore, the accuracy of the data itself is not mandated. This is because of inherent delays associated with measuring the electrical quantities and events such as breaker closing, measurement transport delays, algorithm and measurement calculation techniques, etc.

Ensuring that the monitoring devices internal clocks are within ± 2 ms accuracy will suffice with respect to providing time synchronized data.

Time synchronization of Disturbance monitoring data allows for the time alignment of large volumes of geographically dispersed data records from diverse recording sources. A universally recognized time standard is necessary to provide the foundation for this alignment.

Coordinated Universal Time (UTC) is the foundation used for the time alignment of records. It is an international time standard utilizing atomic clocks for generating precision time measurements at

fractions of a second levels. The local time offset, expressed as a negative number, is the difference between UTC and the local time zone where the measurements are recorded.

Accuracy of time synchronization applies only to the clock used for synchronizing the monitoring equipment.

Time synchronization accuracy is specified in response to Recommendation 12b in the NERC August, 2003, Blackout Final NERC Report Section V Conclusions and Recommendations:

“Recommendation 12b: Facilities owners shall, in accordance with regional criteria, upgrade existing dynamic recorders to include GPS time synchronization...”

Also, from the U.S.-Canada Power System Outage Task Force Interim Report: Causes of the August 14th Blackout, November 2003, in the United States and Canada, page 103:

“Establishing a precise and accurate sequence of outage-related events was a critical building block for the other parts of the investigation. One of the key problems in developing this sequence was that although much of the data pertinent to an event was time-stamped, there was some variance from source to source in how the time-stamping was done, and not all of the time-stamps were synchronized...”

From NPCC’s SP6 Report Synchronized Event Data Reporting, revised March 31, 2005, the investigation by the authoring working group revealed that existing GPS receivers can be expected to provide a time code output which has an uncertainty on the order of 1 millisecond, uncertainty being a quantitative descriptor.

Rationale for Requirement R11

Wide-area Disturbance analysis includes data recording from many devices and entities. Standardized formatting and naming conventions of these files significantly improves timely analysis.

Providing the data within 30 calendar days (or the granted extension time), subject to Part 11.2, allows for reasonable time to collect the data and perform any necessary computations or formatting.

Data is required to be retrievable for 10 calendar days inclusive of the day the data was recorded, i.e. a 10-calendar day rolling window of available data. Data hold requests are usually initiated the same or next day following a major event for which data is requested. A 10-calendar day time frame provides a practical limit on the duration of data required to be stored and informs the requesting entities as to how long the data will be available. The requestor of data has to be aware of the Part 11.1 10-calendar day retrievability because requiring data retention for a longer period of time is expensive and unnecessary.

SER data shall be provided in a simple ASCII .CSV format as outlined in Attachment 2. Either equipment can provide the data or a simple conversion program can be used to convert files into this format. This will significantly improve the data format for event records, enabling the use of software tools for analyzing

the SER data.

This requirement directs the applicable entities, upon requests from the Reliability Coordinator, Regional Entity, or NERC, to provide SER and FR data for BES buses determined in Requirement R1 and DDR data for BES Elements determined as per Requirement R5. To facilitate the analysis of BES Disturbances, it is important that the data is provided to the requestor within a reasonable period of time.

Requirement R11, Part 11.2 specifies the maximum time frame of 30 calendar days to provide the data. Thirty calendar days is a reasonable time frame to allow for the collection of data, and submission to the requestor. An entity may request an extension of the 30-day submission requirement. If granted by the requestor, the entity must submit the data within the approved extended time.

Requirement R11, Part 11.1 specifies that the minimum time period of 10 calendar days inclusive of the day the data was recorded for which the data will be retrievable. With the equipment in use that has the capability of recording data, having the data retrievable for the 10 calendar days is realistic and doable. It is important to note that applicable entities should account for any expected delays in retrieving data and this may require devices to have data available for more than 10 days. To clarify the 10-calendar day time frame, an incident occurs on Day 1. If a request for data is made on Day 6, then that data has to be provided to the requestor within 30 calendar days after a request or a granted time extension. However, if a request for the data is made on Day 11, that is outside the 10 calendar days specified in the requirement, and an entity would not be out of compliance if it did not have the data.

Requirement R11, Part 11.3 specifies a Comma Separated Value (CSV) format according to Attachment 2 for the SER data. It is necessary to establish a standard format as it will be incorporated with other submitted data to provide a detailed sequence of events timeline of a power System Disturbance.

Requirement R11, Part 11.4 specifies the IEEE C37.111 COMTRADE format for the FR and DDR data. The IEEE C37.111 is the Standard for Common Format for Transient Data Exchange and is well established in the industry. It is necessary to specify a standard format as multiple submissions of data from many sources will be incorporated to provide a detailed analysis of a power System Disturbance. The latest revision of COMTRADE (C37.111-2013) includes an annex describing the application of the COMTRADE standard to synchrophasor data.

Requirement R11, Part 11.5 specifies the IEEE C37.232 COMNAME format for naming the data files of the SER, FR and DDR. The IEEE C37.232 is the Standard for Common Format for Naming Time Sequence Data Files. The first version was approved in 2007. From the August 14, 2003 blackout there were thousands of Fault Recording data files collected. The collected data files did not have a common naming convention and it was therefore difficult to discern which files came from which utilities and which ones were captured by which devices. The lack of a common naming practice

seriously hindered the investigation process. Subsequently, and in its initial report on the blackout, NERC stressed the need for having a common naming practice and listed it as one of its top ten recommendations.

Rationale for Requirement R12

Each Transmission Owner and Generator Owner who owns equipment used for collecting the data required for this standard must repair any failures within 90 calendar days to ensure that adequate data is available for event analysis. If the Disturbance monitoring capability cannot be restored within 90 calendar days (e.g. budget cycle, service crews, vendors, needed outages, etc.), the entity must develop a Corrective Action Plan (CAP) for restoring the data recording capability. The timeline required for the CAP depends on the entity and the type of data required. It is treated as a failure if the recording capability is out of service for maintenance and/or testing for greater than 90 calendar days. An outage of the monitored BES Element does not constitute a failure of the Disturbance monitoring capability.

This requirement directs the respective owners of Transmission and Generator equipment to be alert to the proper functioning of equipment used for SER, FR, and DDR data capabilities for the BES buses and BES Elements, which were established in Requirements R1 and R5. The owners are to restore the capability within 90 calendar days of discovery of a failure. This requirement is structured to recognize that the existence of a “reasonable” amount of capability out-of-service does not result in lack of sufficient data for coverage of the System.

Furthermore, 90 calendar days is typically sufficient time for repair or maintenance to be performed. However, in recognition of the fact that there may be occasions for which it is not possible to restore the capability within 90 calendar days, the requirement further provides that, for such cases, the entity submit a Corrective Action Plan (CAP) to the Regional Entity and implement it. These actions are considered to be appropriate to provide for robust and adequate data availability.

Rationale for Requirement R13

Three (3) calendar years of completing a re-evaluation or receiving notification by the Transmission Owner or the Reliability Coordinator is more time than provided in the Implementation Plan of previous versions of this NERC Reliability Standard. The Implementation Plan of previous versions of this Standard provided three years. This time period pertains to those new Elements appearing on the list due to re-evaluation pursuant to Requirement R1, Part 1.3 or Requirement R5, Part 5.4. Having the period built into Requirement R13 maintains visibility of the required time to install monitoring equipment to collect necessary data.

Requirement R13 requires the Transmission Owner and Generator Owner to install monitoring equipment to record required data within three (3) calendar years of completing a re-evaluation or receiving notification that new Elements were identified during re-evaluation pursuant to Requirement R1, Part 1.3 or Requirement R5, Part 5.4 by the Transmission Owner or the Reliability Coordinator.